

WORLD'S ONLY
FULLY ILLUSTRATED
CHRONOGRAPH WATCH COURSE
VOLUME 12

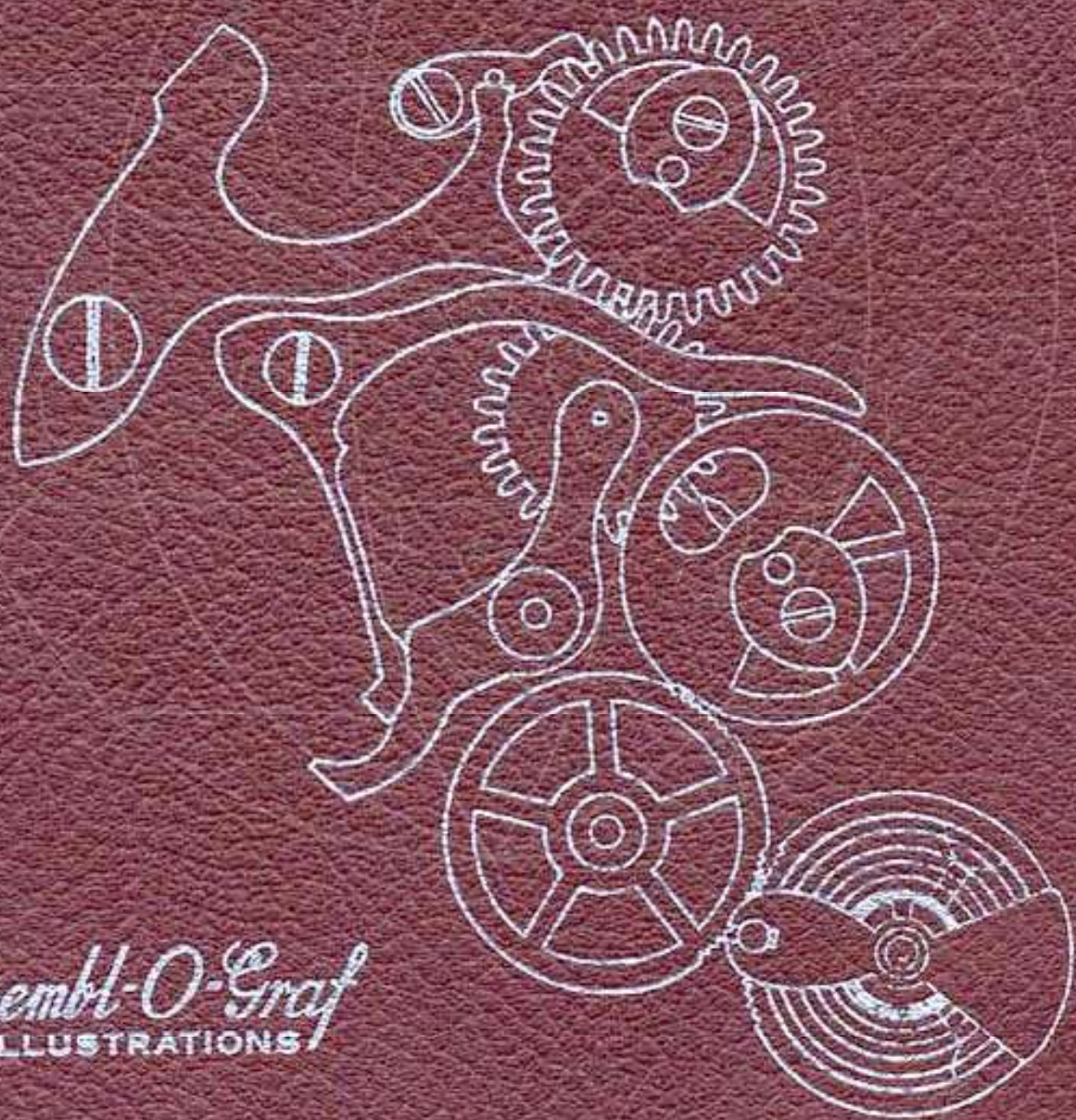

Esseml-O-Graf
ILLUSTRATIONS

IDENTIFICATION OF CHRONOGRAPH

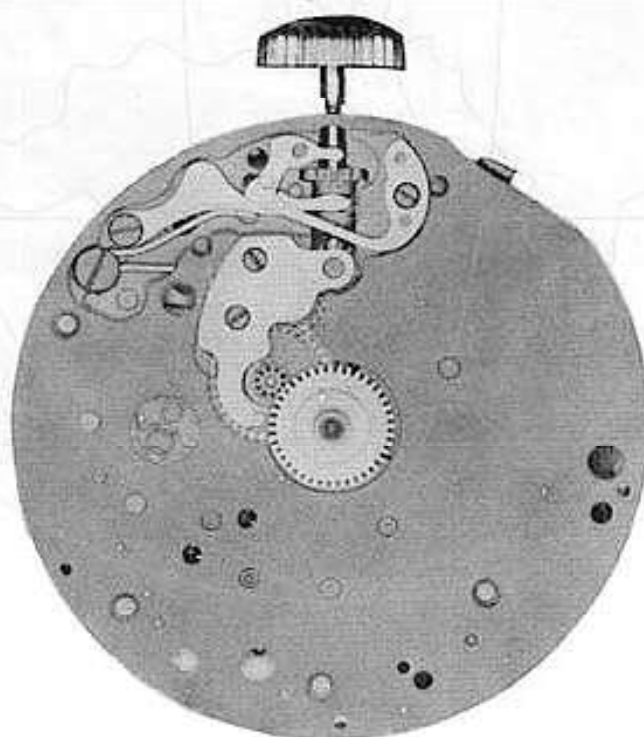

13L

MIDO



MULTI-CENTER
CHRONOGRAPH



ESEMBL-O-GRAF

THE WORLD'S FIRST FULLY
ILLUSTRATED TEXT BOOK
ON
CHRONOGRAPH REPAIRING
AND ADJUSTING

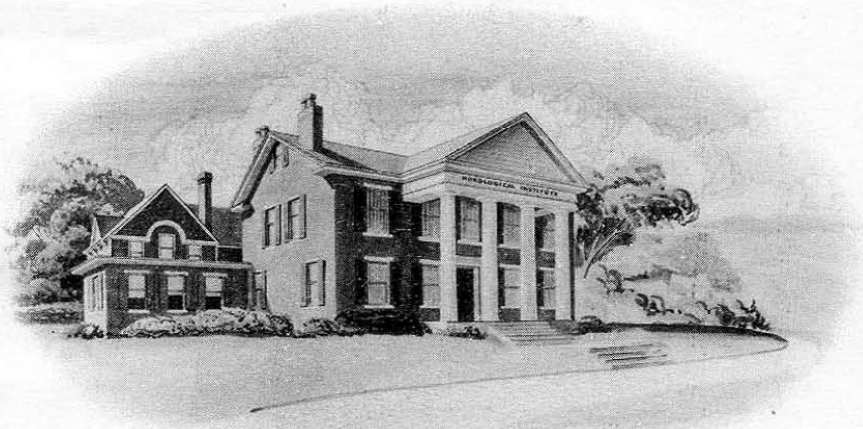

BY
William O. Smith, Sr.
PRESIDENT AND TECHNICAL DIRECTOR
AND
William O. Smith, Jr.
CHIEF ENGINEER, RESEARCH LABORATORIES

WESTERN PENNSYLVANIA HOROLOGICAL INSTITUTE, INC.
PITTSBURGH, PENNSYLVANIA

INSTRUCTIONS

For use of book

DISASSEMBLY OF THE CHRONOGRAPH MECHANISM:

1. Study the isometric drawing at top of page 1-A. The isometric drawing was made for the following purposes:
 - A. It helps to identify the part to be removed.
 - B. This drawing aids in pointing out certain locations on the part that are mentioned in the oiling procedure.
 - C. The text refers to certain points on the part. These points are shown in the isometric drawing. This should aid you in finding the exact location on the part that is described in the text.
 - D. It helps you to know the shape of the part in case a new part has to be made.
2. At the bottom of the page 1-A is a photograph of a chronograph. In this photograph is the same part painted in black. The part is in its exact location that this part occupies in the watch. Find this location in the watch.
3. Read the disassembly procedure and the hazards in disassembly on page 1 in this book.
4. Remove this part in the same procedure as described in the text.
5. A very important item in disassembling a chronograph is keeping the screws in order, much time will be lost in putting the chronograph together if screws are mixed up. This means you have to hunt for each screw, sometimes trying three or four screws before finding the correct one. It cannot be stressed too strongly that care should be taken so that screws are not mixed up. The system that we advise for beginners, is to replace each individual screw after each part is removed. This naturally eliminates the hazard of mixing up the screws and will save you much time in the end. Do this at least until you become so thoroughly familiar with the chronograph that you no longer feel it is necessary.
6. Continue to follow this procedure throughout the book and disassemble each part until the last part of the chronograph is removed.

ASSEMBLY OF THE CHRONOGRAPH MECHANISM:

7. When you are ready to assemble the chronograph mechanism, study the isometric drawing on the last part in this book. This drawing should aid you in identifying the part to be assembled.
8. At the bottom of this page is a photograph of a chronograph. In this photograph is the same part painted in black. The part is in its exact location that this part occupies in the watch.
9. Read the assembly procedure and the hazards in assembling for the last part in this book. (Continued on next page)

INSTRUCTIONS (Continued)

10. Replace the part in its exact location as shown in photograph, using the procedure as described in the text.

11. After you find the correct location for this part in the watch, read the oiling procedure for this part. The oiling procedure for this part is located underneath the isometric drawing. It is best to read the oiling procedure before you put each part in place as there are certain parts that must be oiled immediately as it may prove difficult to oil them later.

12. Replace the screw that holds this part in place. Of course, the screws should be kept in order as we advised above, but if the screws are not in order or the watch was received with screws mixed up, you will find a screw drawn for each part that requires a screw at the bottom of the text page.

13. After replacing this part, replace the next part, etc., until the last part is replaced, which will be part No. 1. Each part should be replaced using the same procedure as described in the text.

(Naturally, the assembly of the chronograph is exactly the reverse of the disassembly)

14. After disassembling and assembling the chronograph mechanism, start on page 1 and read the function of this part. After reading the function of this part, continue to read the function of each part throughout the book. Study each part, one at a time. This text should help you to understand more fully the purpose of each part in the chronograph mechanism.

15. Now put movement in its case with dial on, then replace hands.

16. Study the text on functional results in this book, and check the chronograph mechanism as described in this text.

NOMENCLATURE OF PARTS FOR CHRONOGRAPH MECHANISM











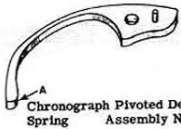
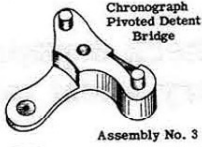

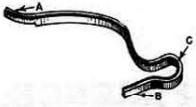
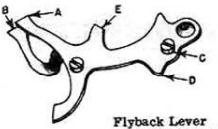
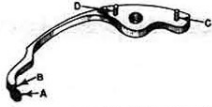

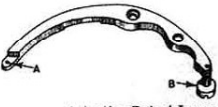

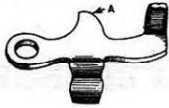
17. After you have become familiar with the chronograph mechanism, you can disassemble and assemble the chronograph by using the nomenclature of parts as a guide. This makes it possible for you to use a procedure without going through each page in the book.

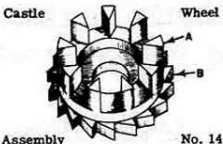
18. ADJUSTMENT OF ECCENTRIC STUDS:

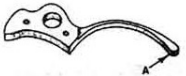
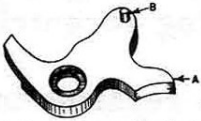
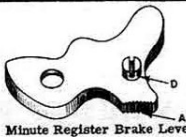
Read the text on adjustment of eccentric studs, this text should be read in reference to the eccentric stud picture. Now adjust each eccentric stud one at a time in the watch, as described in the text. Use the picture to show you the position of these studs.

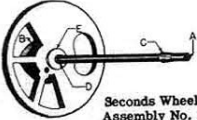
19. On each page in this book the part number and the page number are the same. This makes it convenient for the reader and eliminates any confusion.

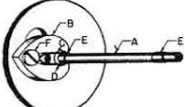
NOMENCLATURE OF PARTS FOR CHRONOGRAPH MECHANISM

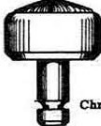
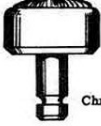
 Wheel Over Fourth Wheel Assembly No. 1	 Chronograph Pivoted Detent Spring Assembly No. 2	 Chronograph Pivoted Detent Bridge Assembly No. 3
 Intermediary Wheel Assembly No. 4	 Chronograph Pivoted Detent Assembly No. 5	 Flyback Lever Spring Assembly No. 6
 Flyback Lever Assembly No. 7	 Actuating detent spring Assembly No. 8	 Joint Hook Assembly No. 9
 Actuating Detent Lever Assembly No. 10	 Push Piece Plate Assembly No. 11	 Push Piece For Setting Back To Zero Assembly No. 12
 Castle Wheel Pawl Assembly No. 13	 Castle Wheel Assembly No. 14	 Brake Lever Spring Assembly No. 15
 Minute Register Brake Lever Spring Assembly No. 16	 Brake Lever Assembly No. 17	 Minute Register Brake Lever Assembly No. 18
 Seconds Wheel and Minute Register Wheel Bridge Assembly No. 19	 Seconds Wheel Assembly No. 20	 Seconds Wheel Tension Spring Assembly No. 21
 Minute Register Wheel Assembly No. 22	 Sweep Second Hand	 Minute Register Hand
 Chronograph Button	 Chronograph Button	

ADJUSTING ECCENTRIC STUDS

Listed below are a number of depthings and adjustments controlled by eccentric studs:

1. Check depthing of wheel over fourth wheel with the intermediary wheel teeth.

CORRECTION: If this depthing is incorrect, it can be corrected by adjusting eccentric stud ES-1.

REFERENCE: Wheel over fourth wheel is Assembly 1.
Intermediary wheel is Assembly 4.

2. Check depthing of seconds wheel teeth with intermediary wheel teeth.

CORRECTION: If this depthing is incorrect, it can be corrected by adjusting eccentric stud ES-2.

REFERENCE: Seconds wheel is Assembly 20.
Intermediary wheel is Assembly 4.

3. Check to see that the minute register wheel brake lever engages with the minute register wheel.

CORRECTION: If brake lever does not contact minute register wheel properly, it can be corrected by adjusting eccentric stud ES-3.

REFERENCE: Minute register brake lever is Assembly 18.
Minute register wheel is Assembly 22.

ADJUSTING ECCENTRIC STUDS

DO NOT REMOVE THESE STUDS

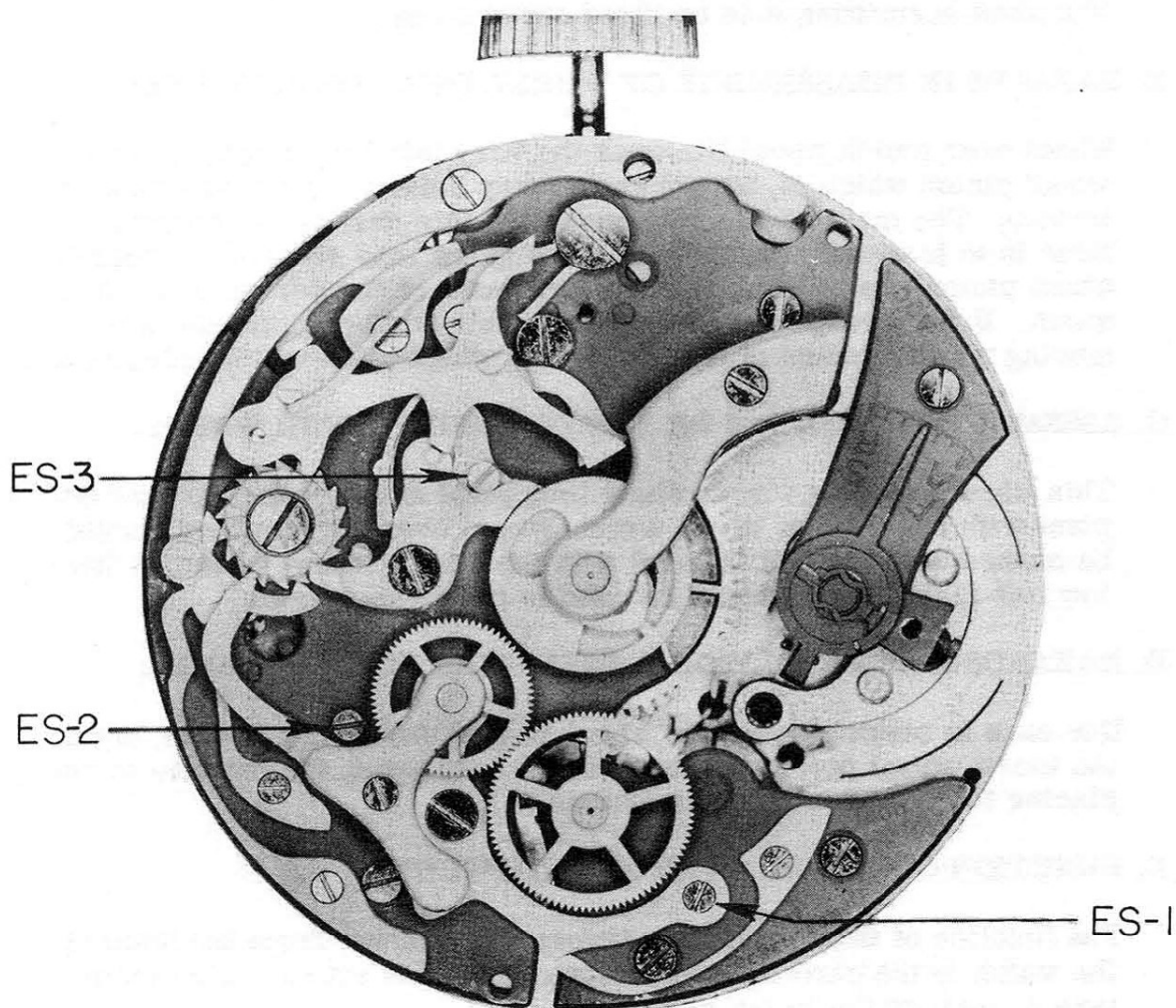

CAUTION

In disassembling or assembling chronograph it is a good policy not to turn eccentric studs. These eccentric studs are used to adjust one part to another and naturally in turning these studs you will lose the desired adjustment of the chronograph mechanism which will cause the chronograph to function incorrectly. Another reason for not turning these studs unless it is necessary is that they soon become loose and will not hold the desired adjustment.

PART NO. 1

A. DISASSEMBLY PROCEDURE OF WHEEL OVER FOURTH WHEEL:

Wheel over fourth wheel fits friction tight on long pivot of fourth wheel pinion. This wheel should be removed with a sweep wheel remover but can be removed with two small thin edge screw-drivers. The screw-drivers are placed opposite each other under hub "A" of wheel. One screw-driver is turned clockwise while the other screw-driver is turned counter-clockwise. This will loosen the wheel from the pivot permitting it to be lifted out of place.

B. HAZARDS IN DISASSEMBLY OF WHEEL OVER FOURTH WHEEL:

Wheel over fourth wheel fits over the very thin long pivot of fourth wheel pinion which is, as you know, very delicate and easily bent or broken. The main reason why we select this part to be removed first is to lessen the hazards of bending the long pivot on the fourth wheel pinion when removing the other parts of the chronograph mechanism. If the sweep wheel remover is held perfectly upright in removing wheel, hazard of bending fourth wheel pivot will be eliminated.

C. ASSEMBLY PROCEDURE OF WHEEL OVER FOURTH WHEEL:

This wheel fits over fourth wheel long pivot and should be placed on pivot with hub "A" of wheel down. Wheel over fourth wheel should be pushed down until it is level with the intermediary wheel. A hollow flat-faced punch should be used to push wheel down.

D. HAZARDS IN ASSEMBLY OF WHEEL OVER FOURTH WHEEL:

Use care in staking down this wheel so that you do not bend or break the fourth wheel pivot. If movement is held level, the hazards of replacing this wheel will be eliminated.

E. FUNCTION OF WHEEL OVER FOURTH WHEEL:

The function of this wheel is to transmit the power from the train of the watch to the chronograph mechanism. This wheel continues to turn as long as the watch is running.

REMARKS:

Mechanically we should regard this wheel as an intermediate chronograph wheel, as it is the main wheel which transfers the power from the movement train to the chronograph mechanism. The Swiss term for this part is "wheel over fourth wheel", and we will use this term to describe this wheel.

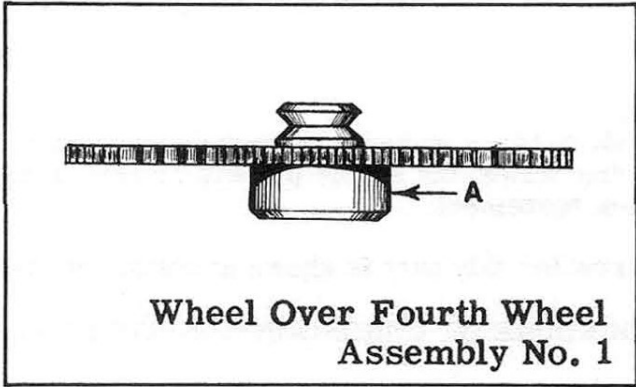

OILING

The wheel over fourth wheel should not be oiled.



1-A

PART NO. 2

A. DISASSEMBLY PROCEDURE OF CHRONOGRAPH PIVOTED DETENT SPRING:

This spring is held in place by beveled countersink screw BS-1 and a steady pin. After removing screw, the steady pin will be free in plate and spring may be lifted from movement.

(The shape of screw for this part is shown at bottom of page)

B. ASSEMBLY PROCEDURE OF CHRONOGRAPH PIVOTED DETENT SPRING:

Place spring in position on plate with steady pin in proper hole in plate. Now replace beveled countersink screw BS-1 that holds spring in position.

C. HAZARDS IN ASSEMBLY OF CHRONOGRAPH PIVOTED DETENT SPRING:

The free end of this spring fits very close to the plate. The spring and plate where these two parts meet should be checked for burrs that would cause the spring to bind on plate.

D. FUNCTION OF CHRONOGRAPH PIVOTED DETENT SPRING:

The tension of this spring moves the chronograph pivoted detent to engage the intermediary wheel with the seconds wheel.

REFERENCE: Intermediary wheel is Assembly 4.
Chronograph pivoted detent is Assembly 5.
Seconds wheel is Assembly 20.

REMARKS:

At this point the intermediary wheel should be checked to see that it will not rise enough to be out of mesh with seconds wheel.

The endshake of the intermediary wheel, plus the vertical movement or endshake of chronograph pivoted detent under the screw-head that holds it in place should not be enough to permit the intermediary wheel to rise enough to be out of mesh with the seconds wheel.

Any excess freedom of chronograph pivoted detent under screw-head plus the endshake of intermediary wheel may permit the intermediary wheel to drop below the seconds wheel when the chronograph is placed in a dial up position.

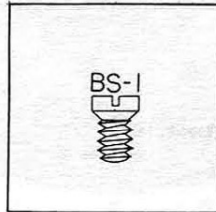

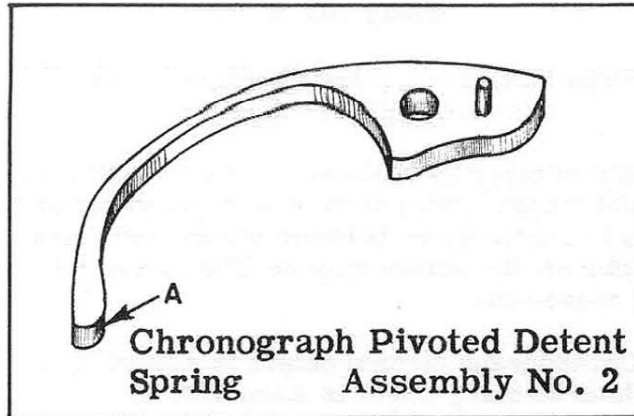

OILING

End "A" of chronograph pivoted detent spring should be slightly moistened with oil at point of contact with chronograph pivoted detent.

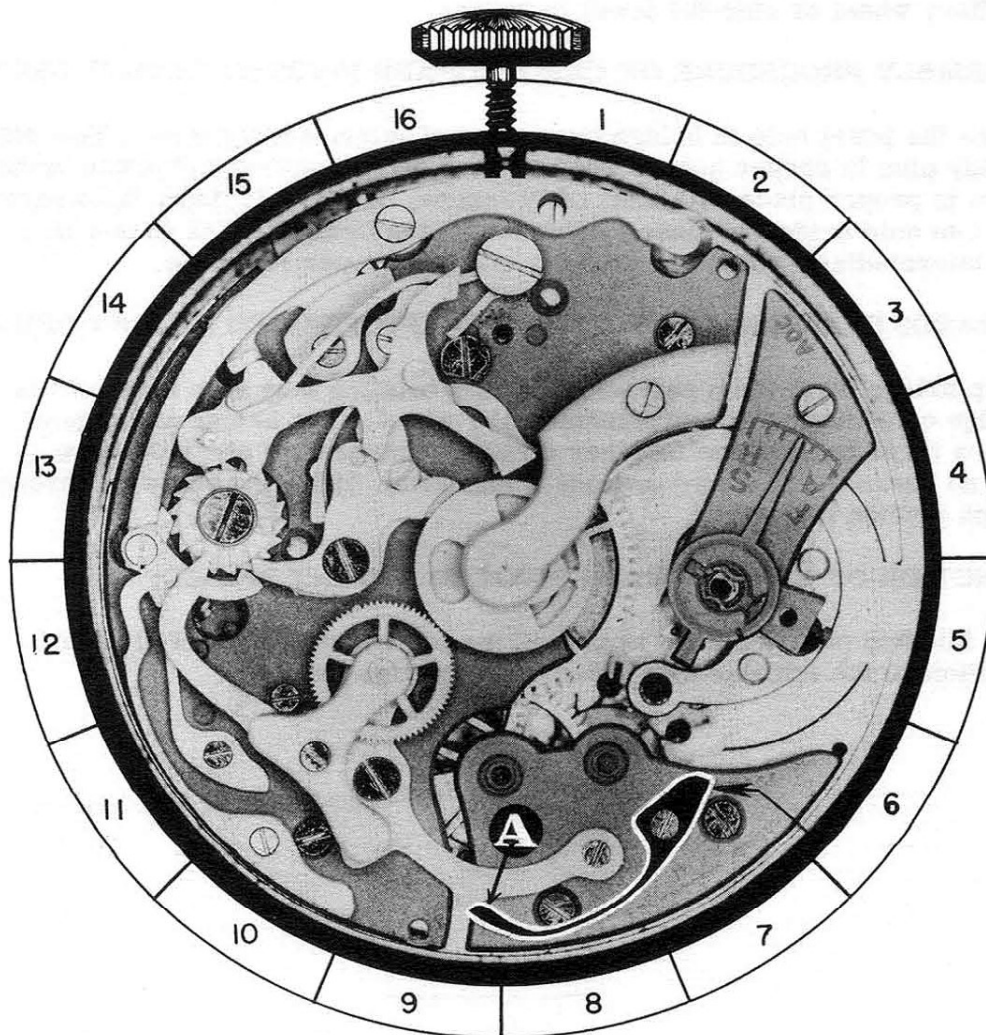

2-A

PART NO. 3

A. DISASSEMBLY PROCEDURE OF CHRONOGRAPH PIVOTED DETENT BRIDGE:

This bridge is held in place by fillister head screw FS-1 and steady pins. Remove screw and loosen bridge from chronograph pivoted detent by sliding a thin-blade screwdriver between bridge and detent. When steady pins are free in detent, the bridge may be lifted from intermediary wheel pivot and free of movement.

REFERENCE: Chronograph pivoted detent is Assembly 5.
Intermediary wheel is Assembly 4.

(The shape of screw for this part is shown at bottom of page)

B. HAZARDS IN DISASSEMBLY OF CHRONOGRAPH PIVOTED DETENT BRIDGE:

When removing the bridge from the intermediary wheel pivot, the bridge should be lifted straight up, lifting the jewel from pivot. Care should be taken to keep bridge level, as any twisting may damage the pivot on intermediary wheel or chip the jewel in bridge.

C. ASSEMBLY PROCEDURE OF CHRONOGRAPH PIVOTED DETENT BRIDGE:

Place the jewel hole in bridge over pivot of intermediary wheel. Now place steady pins in proper hole in chronograph pivoted detent and press bridge down to proper place with back of tweezers. Replace fillister head screw FS-1 to hold bridge in place. After replacing bridge, check to see that the intermediary wheel spins freely and has proper endshake.

D. HAZARDS IN ASSEMBLY OF CHRONOGRAPH PIVOTED DETENT BRIDGE:

Keep bridge level when replacing, as any twisting may chip the jewel in bridge or damage pivot on intermediary wheel. The bridge and detent where these parts come together should be checked to see that there are no burrs which would prevent bridge from fitting properly on chronograph pivoted detent.

E. FUNCTION OF CHRONOGRAPH PIVOTED DETENT BRIDGE:

The function of this bridge is to hold the intermediary wheel pivot in position so the intermediary wheel can function properly.

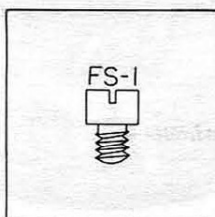

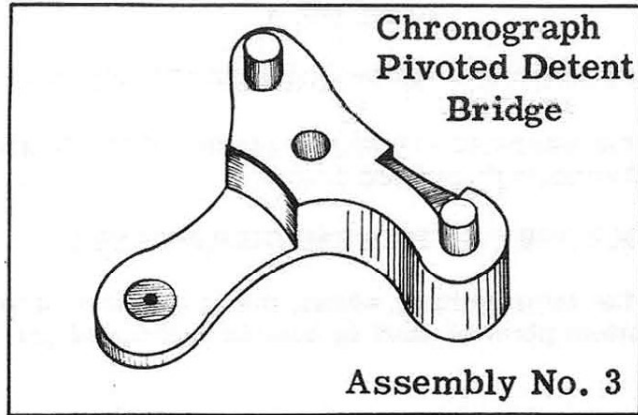

OILING

The pivot in the jewel in this bridge should be oiled as you would properly oil a train pivot in a watch.



3-A

PART NO. 4

A. DISASSEMBLY PROCEDURE OF INTERMEDIARY WHEEL:

When removing the intermediary wheel, lift the wheel straight up to remove the pivot from chronograph pivoted detent.

B. ASSEMBLY PROCEDURE OF INTERMEDIARY WHEEL:

When replacing the intermediary wheel, the long end of staff "A" is placed down with the bottom pivot of staff in hole in bushing of chronograph pivoted detent.

REFERENCE: Chronograph pivoted detent is Assembly 5.

C. HAZARDS IN ASSEMBLY OF INTERMEDIARY WHEEL:

The pivot hole in bushing of chronograph pivoted detent should be carefully examined for any imperfections before replacing intermediary wheel. Any imperfections here will affect the timekeeping of watch and will hinder the proper operation of the chronograph.

D. FUNCTION OF INTERMEDIARY WHEEL:

The function of the intermediary wheel is to transfer the power from the wheel over fourth wheel to seconds wheel, when these wheels are engaged. The intermediary wheel continues to turn as long as the watch is running.

REFERENCE: Wheel over fourth wheel is Assembly 1.
Seconds wheel is Assembly 20.

REMARKS:

A careful and detailed examination should be made of all wheels before replacing in the chronograph. Each wheel should be examined for burred pivots, bent or burred teeth, dirt or small pieces of grit wedged between the teeth, or any parts which may be loose on the wheel.

Often, due to carelessness or lack of detailed observation, the chronograph is completely assembled before some defect is discovered, and may necessitate the complete disassembly of the chronograph. A close examination of these wheels will not only save time by having the wheels correct before replacing in the chronograph, but through close examination, you will learn to quickly recognize a defective wheel.

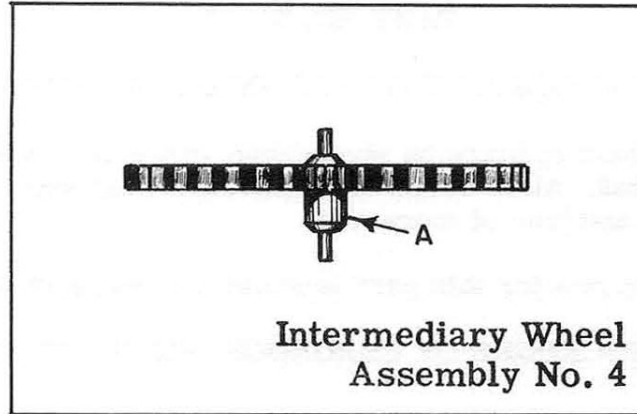

OILING

The bottom pivot on intermediary wheel should be oiled before putting this part in place on chronograph pivoted detent.



4-A

PART NO. 5

A. DISASSEMBLY PROCEDURE OF CHRONOGRAPH PIVOTED DETENT:

This detent is held in place by shouldered screw SS-1 and pivots on an eccentric stud. After screw is removed, detent may be lifted from eccentric stud and free of movement.

(The shape of screw for this part is shown at bottom of page)

B. ASSEMBLY PROCEDURE OF CHRONOGRAPH PIVOTED DETENT:

Place detent in proper position on plate with hole in end of detent over eccentric stud, as detent pivots on this stud. When detent is in proper place, shouldered screw SS-1 may be replaced. After replacing detent, check to see that it has enough freedom to work freely under head of screw and yet does not have excess freedom.

C. FUNCTION OF CHRONOGRAPH PIVOTED DETENT:

The function of the chronograph pivoted detent is to engage and disengage the intermediary wheel with the seconds wheel.

REFERENCE: Seconds wheel is Assembly 20.
Intermediary wheel is Assembly 4.

REMARKS:

When disassembling the chronograph, each part should be carefully examined as it is removed from the movement. Each part should be checked against the isometric drawings to see that the part is the correct shape and is not broken. Each part should also be checked for any pits of rust, roughness, or burrs and for worn parts which may cause the part not to work properly.

The replacement of a defective part in the chronograph may necessitate complete disassembly of the chronograph. It will save time in the end to make this examination and the necessary corrections to each defective part while disassembling the chronograph. Through this close examination, you will soon become familiar with the various parts of the mechanism. This will enable you to quickly recognize a defective part and repair it before replacing in the chronograph.

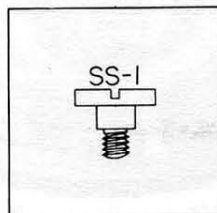

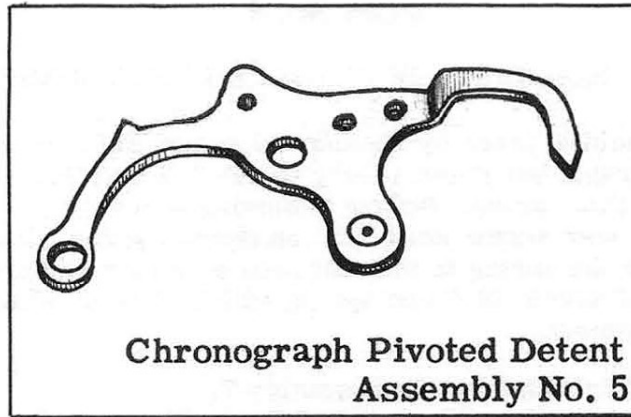

Chronograph Pivoted Detent
Assembly No. 5

OILING

The eccentric stud that the chronograph pivoted detent pivots on should be slightly moistened with oil.

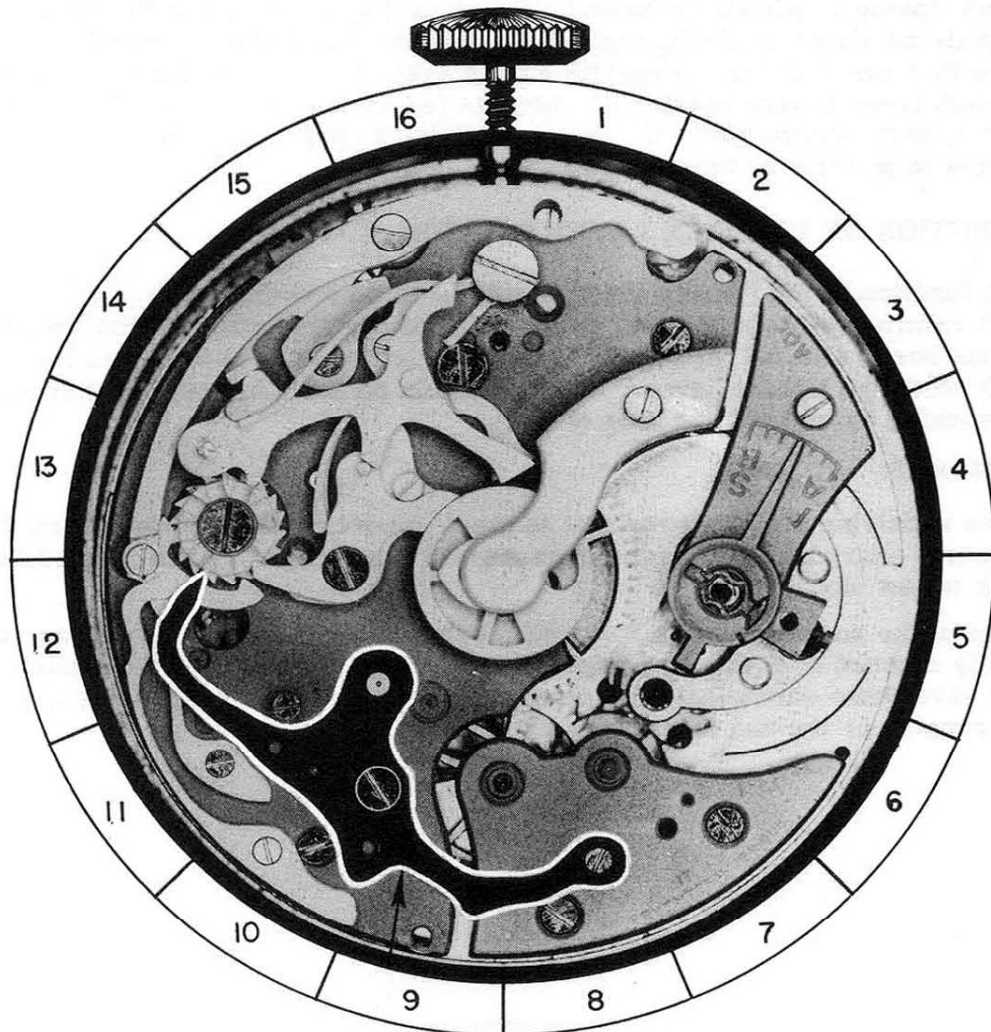

5-A

PART NO. 6

A. DISASSEMBLY PROCEDURE OF FLYBACK LEVER SPRING:

This spring is held in place by shouldered screw SS-2 and screw "D" as shown in photograph, but is necessary to remove only the shouldered screw SS-2 to remove this spring. Before removing screw, the end "A" of spring should be lifted over screw-head "C" on flyback lever. This will remove the tension from the spring to prevent loss of spring or screw. Now remove shouldered screw SS-2 and spring will be free on plate, and may be lifted from movement.

REFERENCE: Flyback lever is Assembly 7.

(The shape of screw for this part is shown at bottom of page)

B. HAZARDS IN DISASSEMBLY OF FLYBACK LEVER SPRING:

Be sure to remove the end "A" of spring from screw on flyback lever before removing the screw that holds the spring in place.

C. ASSEMBLY PROCEDURE OF FLYBACK LEVER SPRING:

Place spring in position with end "B" of spring in contact with screw "D" in plate as shown in photograph. Now replace shouldered screw SS-2, making sure that part "C" of spring fits snugly against shoulder of screw. Now turn flyback lever toward outside of watch as far as it will go, and lift end "A" of spring over screw-head "C" on top of flyback lever. This will place the spring in position to function properly.

D. FUNCTION OF FLYBACK LEVER SPRING:

The function of the flyback lever spring is to do two things:

1. It returns the flyback lever to its original position after manual pressure has been released, and holds it in this position until it is moved manually.
2. It holds the flyback lever down in position on stud, preventing it from working up and coming free of stud.

REMARKS:

When repairing a chronograph, it is most important that screwdrivers are properly sharpened and the correct size of screwdriver blade is used for each screw slot.

Most of the screws used in a chronograph are highly polished and are very easily marred by a slight slip of the screwdriver. To repair a chronograph and have these screw-heads marred indicates carelessness, either in the sharpening or the use of the screwdriver.

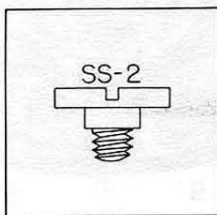

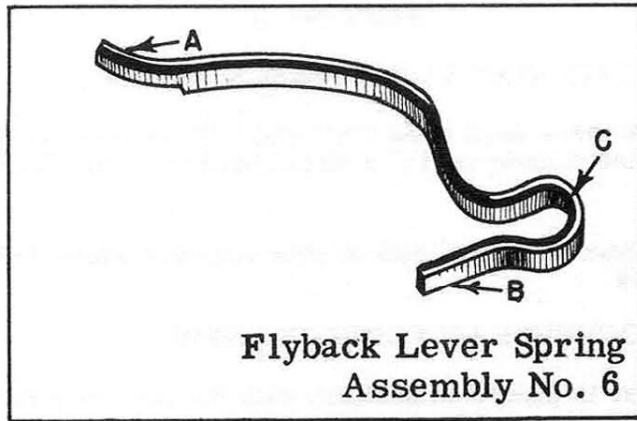

OILING

End "A" on the flyback lever spring should be slightly moistened with oil at point of contact with screw on flyback lever.

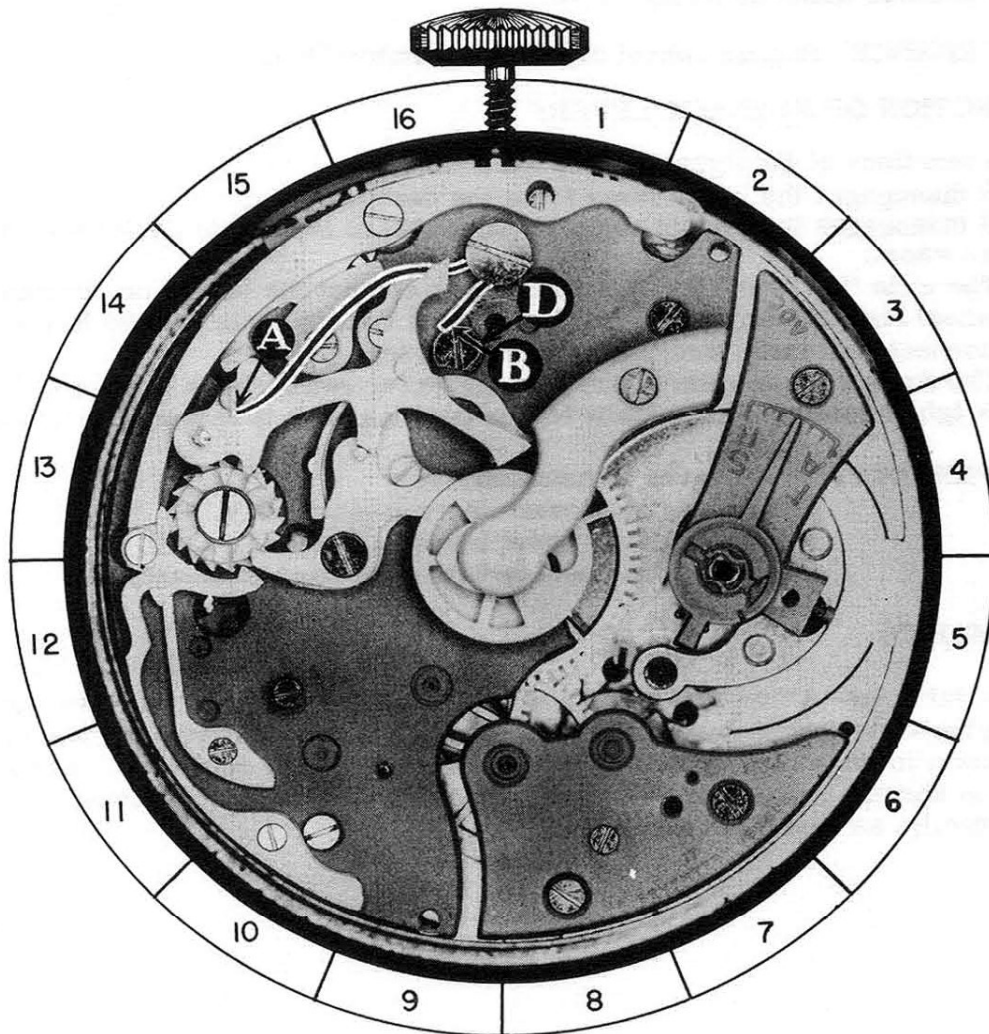

6-A

PART NO. 7

A. DISASSEMBLY PROCEDURE OF FLYBACK LEVER:

Turn the flyback lever until ends "A" and "B" of flyback lever will clear seconds wheel and minute register wheel bridge. Now lift flyback lever from stud on plate.

REFERENCE: Seconds wheel and minute register wheel bridge is Assembly 19.

B. ASSEMBLY PROCEDURE OF FLYBACK LEVER:

The flyback lever is placed in position with the screw-head "C" up and the hole in bushing in flyback lever over stud in plate. Now move ends "A" and "B" of flyback lever so they will clear the seconds wheel and minute register wheel bridge, and press flyback lever down to proper place on stud. Check to see that lever pivots freely on stud in plate.

C. HAZARDS IN ASSEMBLY OF FLYBACK LEVER:

Before pressing flyback lever down on stud, check to see that the end "A" of flyback lever is not on top of heart on the seconds wheel as this may damage seconds wheel or flyback lever.

REFERENCE: Seconds wheel heart is Assembly 20-B.

D. FUNCTION OF FLYBACK LEVER:

The functions of the flyback lever are:

1. It disengages the brake lever from the seconds wheel.
2. It disengages the minute register wheel brake lever from minute register wheel.
3. The ends "A" and "B" of flyback lever contact the hearts on seconds wheel and minute register wheel, forcing these wheels and the hands connected to these wheels to return to a zero position.
4. The flyback lever returns the push piece for setting back to zero to its original position and holds it in this position until it is moved manually.

REFERENCE: Brake lever is Assembly 17.

Minute register brake lever is Assembly 18.

Minute register wheel heart is Assembly 22-B.

Push piece for setting back to zero is Assembly 12.

REMARKS:

The flat ends "A" and "B" of flyback lever must be highly polished, as any roughness or pits of rust at this location may cause the flyback lever to function improperly. When polishing these ends, care should be taken so as not to shorten one end more than the other or they will not function correctly, as described above.

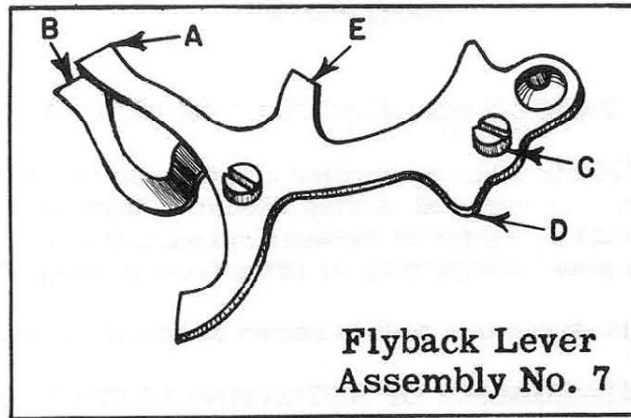

The flyback lever should be slightly moistened with oil at these points:

1. The stud on which flyback lever pivots.
2. Point "D" at point of contact with push piece for setting back to zero.
3. End "E" at point of contact with pin "B" on brake lever.

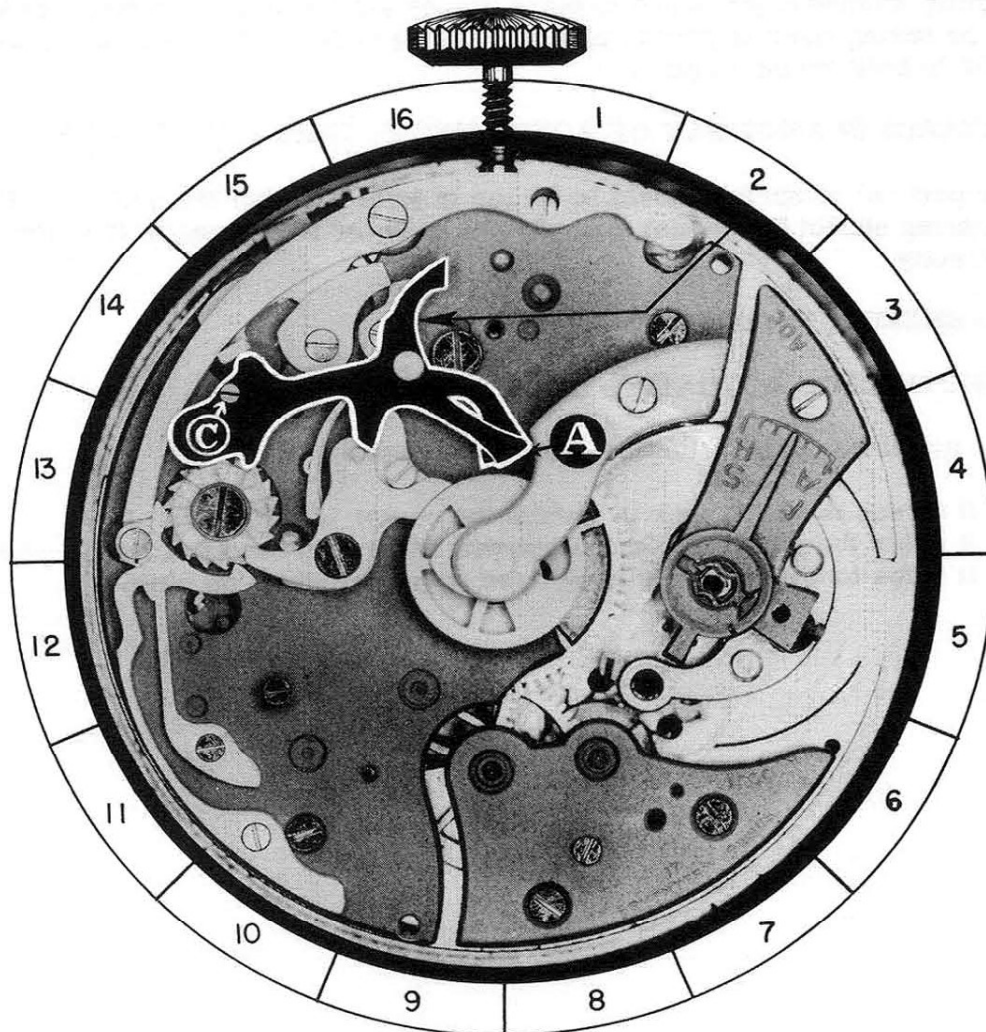

7-A

PART NO. 8

A. DISASSEMBLY PROCEDURE OF ACTUATING DETENT LEVER SPRING:

This spring is held in place by beveled countersink screw BS-2 and steady pins. After screw is removed, spring should be loosened from plate by sliding a thin blade screwdriver between spring and plate. When steady pins are free in plate, spring may be lifted from movement.

(The shape of screw for this part is shown at bottom of page)

B. HAZARDS IN DISASSEMBLY OF ACTUATING DETENT LEVER SPRING:

Hold finger on spring while removing screw and loosening it from the plate, this will prevent loss of spring or screw.

C. ASSEMBLY PROCEDURE OF ACTUATING DETENT LEVER SPRING:

Place spring in position with steady pin 'C' started in proper hole in plate. Now place part 'A' of spring in place on joint hook. Apply pressure to center of spring toward center of watch, and at the same time apply a slightly downward pressure to place steady pin 'D' in proper hole. Now press spring down in proper place and replace beveled countersink screw BS-2 to hold spring in place.

D. HAZARDS IN ASSEMBLY OF ACTUATING DETENT LEVER SPRING:

The part 'A' of spring should be on top of joint hook but the shoulder 'B' of spring should fit against side of joint hook for the spring to function correctly.

REFERENCE: Joint hook is Assembly 9.

E. FUNCTIONS OF ACTUATING DETENT LEVER SPRING:

The functions of the actuating detent lever spring are:

1. It forces the joint hook in toward the center of the watch
2. It holds the joint hook in contact with the ratchet teeth of castle wheel
3. It helps to hold the joint hook down in proper place on plate.

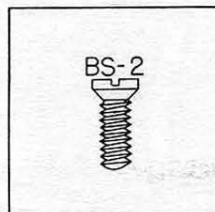

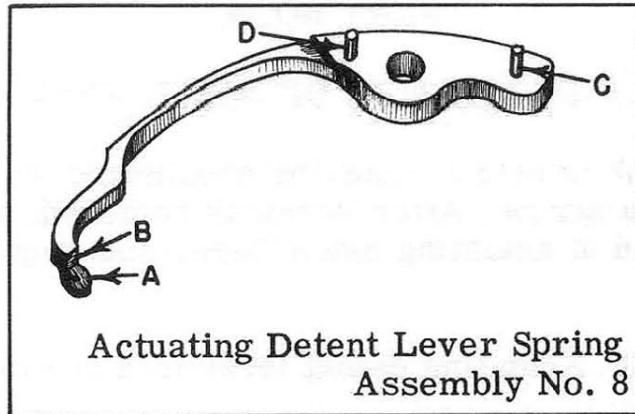

Actuating Detent Lever Spring
Assembly No. 8

OILING

End "A" on actuating detent lever spring should be slightly moistened with oil at point of contact with joint hook.

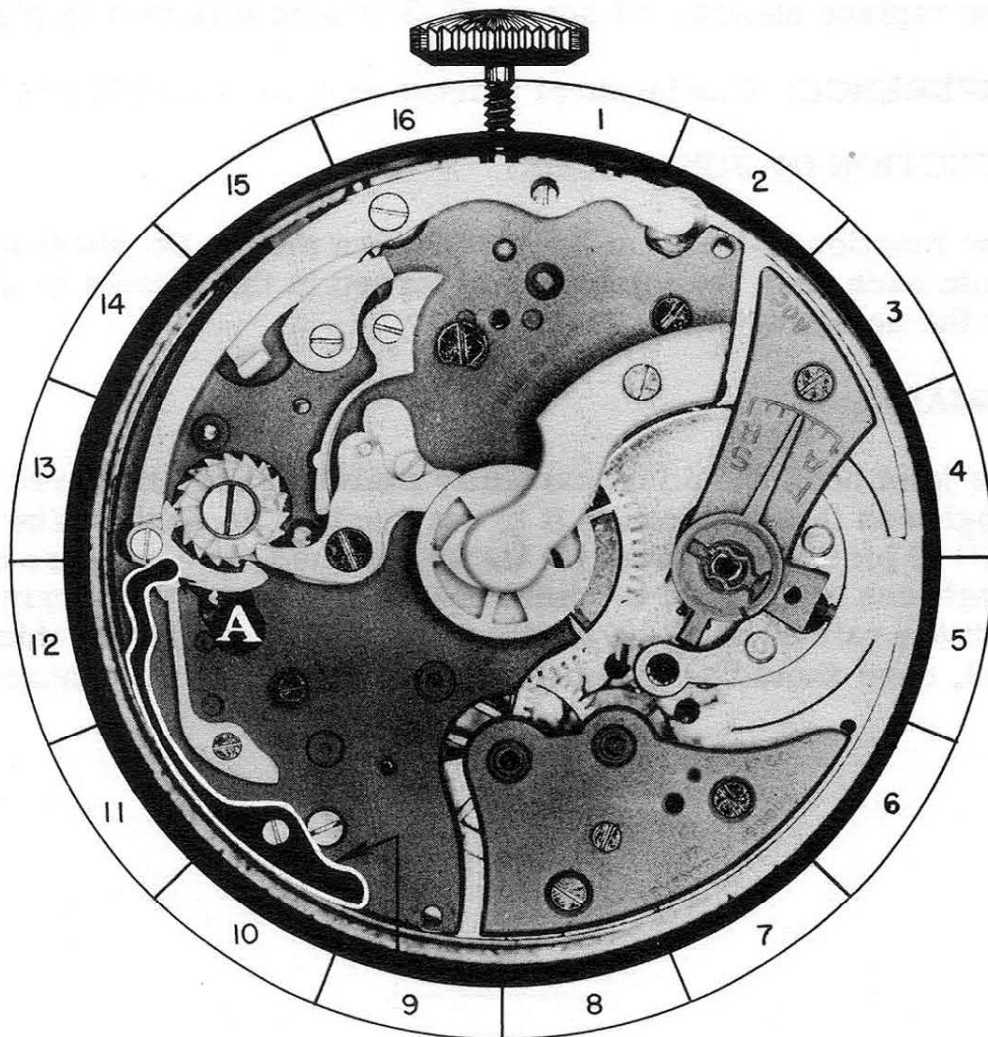

8-A

PART NO. 9

A. DISASSEMBLY PROCEDURE OF JOINT HOOK:

The joint hook is held in place by shouldered screw SS-3 and pivots on this screw. After screw is removed, joint hook will be free on end of actuating detent lever and may be lifted from movement.

REFERENCE: Actuating detent lever is Assembly 10.

(The shape of screw for this part is shown at bottom of page)

B. ASSEMBLY PROCEDURE OF JOINT HOOK:

The joint hook is placed in position with the hole in joint hook over end "A" of actuating detent lever and the end "A" of joint hook in contact with the ratchet teeth on castle wheel. Now replace shouldered screw SS-3 to hold this part in place.

REFERENCE: Castle wheel ratchet teeth is Assembly 14-B.

C. FUNCTION OF JOINT HOOK:

The function of the joint hook is to turn the castle wheel one tooth each time the joint hook is forced to the outside of watch by the actuating detent lever.

REMARKS:

The joint hook should be carefully examined for any burrs or roughness that may cause it to not function properly. The end "A" of joint hook should be highly polished, as any burrs or roughness may cause the joint hook not to engage properly with the ratchet teeth on castle wheel. When polishing this part, care should be taken that shape of hook is not changed.

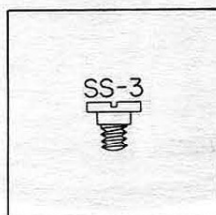

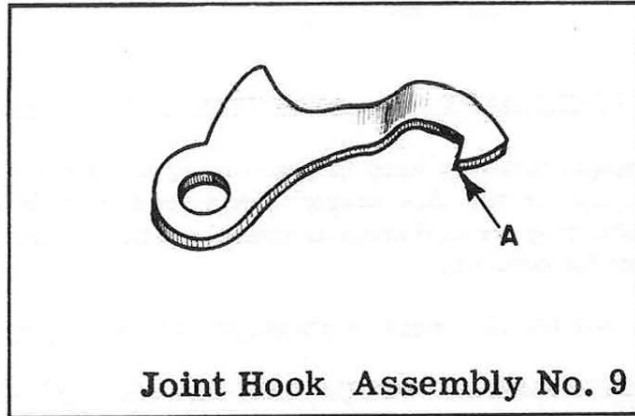

OILING

The shoulder of screw that the joint hook pivots on should be slightly moistened with oil.

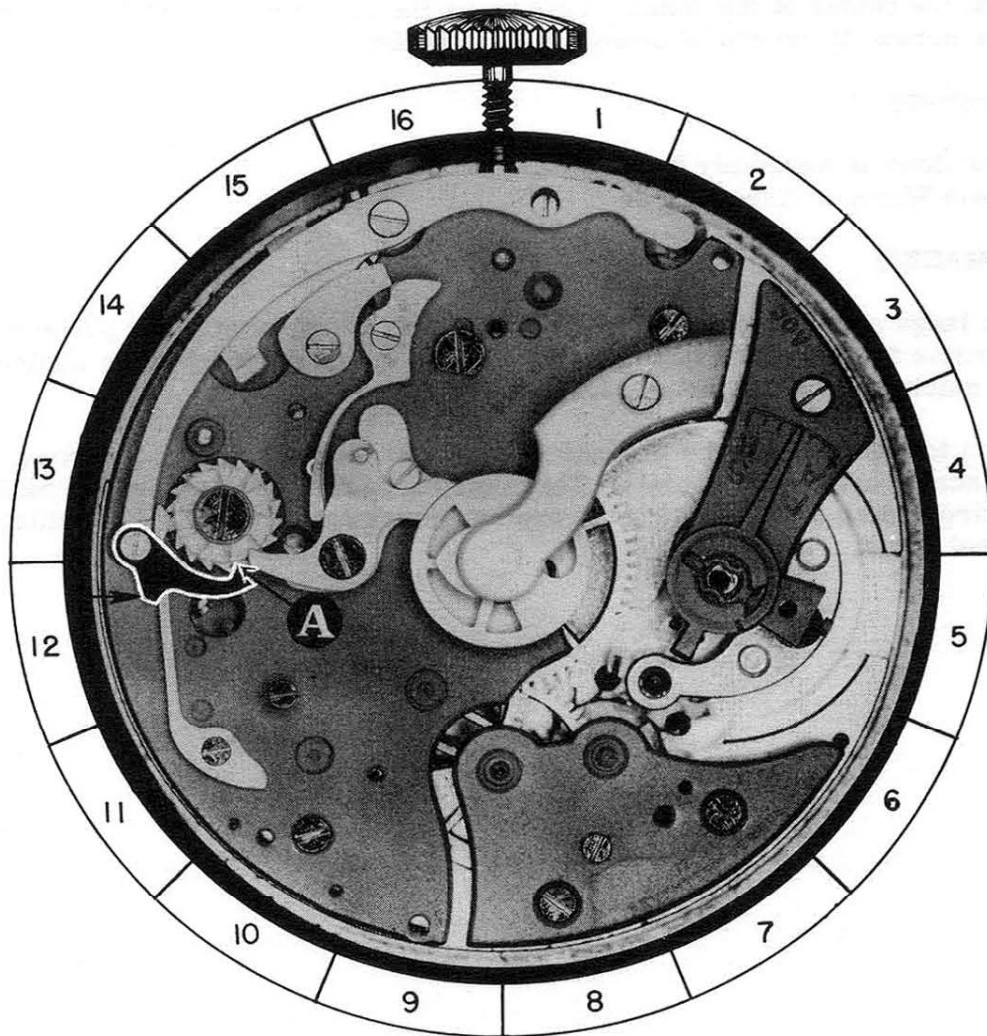

9-A

PART NO. 10

A. DISASSEMBLY PROCEDURE OF ACTUATING DETENT LEVER:

This actuating detent lever is held in place by shouldered screw SS-4 and pivots on this screw. After this screw is removed, screw head 'B' on actuating detent lever may be slid from between top and bottom plates and detent lifted from movement.

(The shape of screw for this part is shown at bottom of page)

B. ASSEMBLY PROCEDURE OF ACTUATING DETENT LEVER:

Place detent lever in position on plate as shown in the photograph, with screw 'B' of detent between plates of watch. When detent is in proper place, shouldered screw SS-4 can be replaced. Detent lever should pivot freely under the head of this screw.

C. FUNCTION OF ACTUATING DETENT LEVER:

The function of the actuating detent lever is to move the joint hook away from the center of the watch. This turns the castle wheel one tooth each time screw 'B' on end of detent lever is pushed.

Reference:

Joint Hook is Assembly 9
Castle Wheel is Assembly 14

REMARKS:

The large screw-head "B" on the end of actuating detent lever prevents the operator from causing damage to the chronograph mechanism by applying too much pressure to the chronograph button.

When too much pressure is applied to the chronograph button it forces the screw-head against plate. This limiting of the movement of screw-head toward center of watch prevents excess movement of end "A" of actuating detent lever.

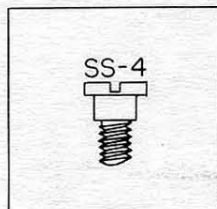

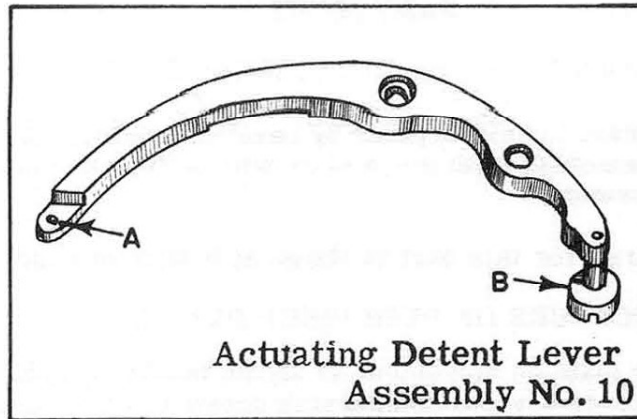

OILING

The shoulder of screw that actuating detent lever pivots on should be slightly moistened with oil.

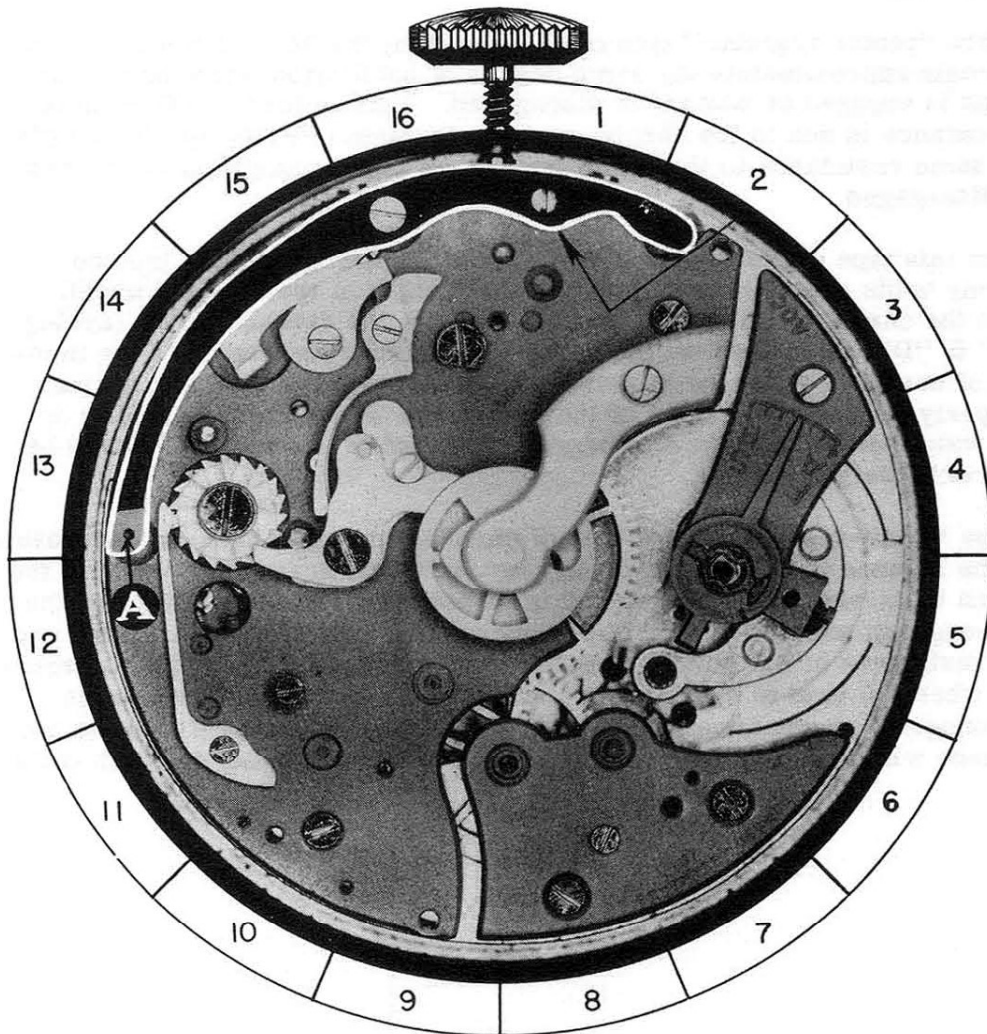

10-A

PART NO. 11

A. DISASSEMBLY PROCEDURE OF PUSH PIECE PLATE:

The push piece plate is held in place by beveled countersink screw BS-3. After screw is removed, push piece plate will be free on plate and may be lifted from movement.

(The shape of screw for this part is shown at bottom of page)

B. ASSEMBLY PROCEDURE OF PUSH PIECE PLATE:

Place push piece plate on movement as shown in photograph. With plate in this position, replace beveled countersink screw BS-3 to hold plate in position.

C. FUNCTION OF PUSH PIECE PLATE:

The function of this plate is to hold the push piece for setting back to zero in position to function properly.

REFERENCE: Push piece for setting back to zero is Assembly 12.

REMARKS:

In this "center register" type of chronograph, the balance wheel should maintain approximately the same degree of oscillation when the chronograph is engaged or when it is disengaged. This uniform oscillation of the balance is due to the chronograph mechanism offering approximately the same resistance to the watch train when the chronograph is engaged or disengaged.

When this type of chronograph is engaged, the seconds wheel tension spring holds a certain resistance to the turning of the seconds wheel. With the chronograph mechanism disengaged, the driving spring (spring "C" & "D") on minute register wheel, creates a resistance to the turning of center post, as the post turns in this spring. With these springs properly adjusted, the value of the resistance offered to the running of the watch either with the chronograph engaged or disengaged, should be approximately the same.

In the "semi-instantaneous" type of chronograph, this uniform oscillation of the balance is not usually observed, due to the heavy resistance to the watch train when the chronograph is registering. The resistance of the chronograph wheels, the friction of the seconds wheel tension spring and the resistance of the minute register pawl to the turning of minute register wheel all tend to shorten the oscillation of the balance. When the chronograph mechanism is completely disengaged, the oscillation of the balance will increase due to less resistance to the turning of watch train.

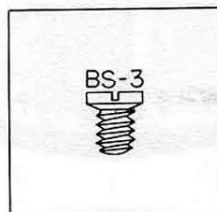

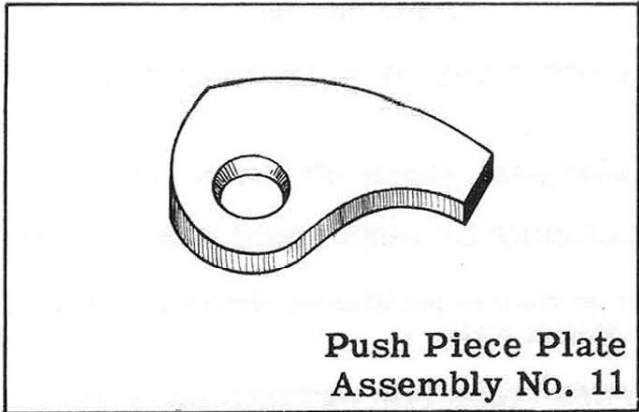

**Push Piece Plate
Assembly No. 11**

OILING

The push piece plate should not be oiled.

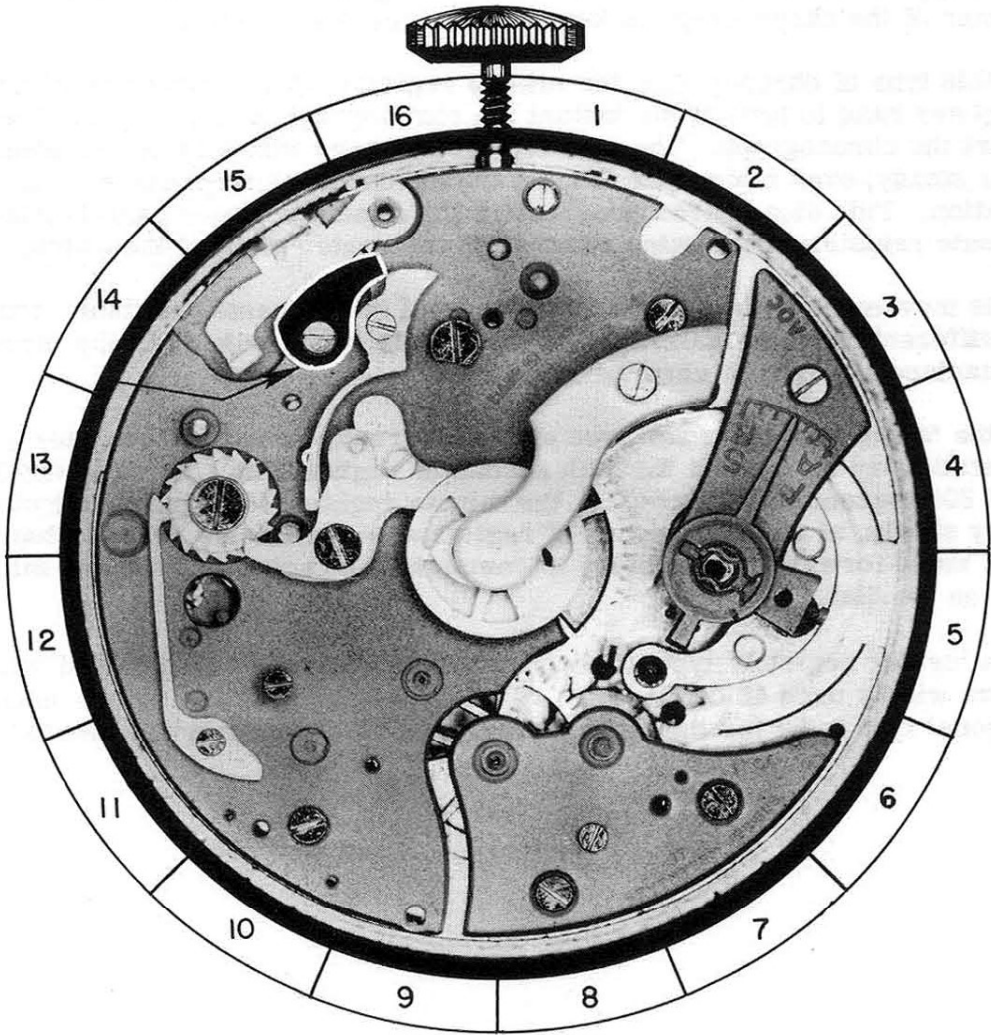

11-A

PART NO. 12

A. DISASSEMBLY PROCEDURE OF PUSH PIECE FOR SETTING BACK TO ZERO:

To remove this push piece, simply lift it from post on plate.

B. ASSEMBLY PROCEDURE OF PUSH PIECE FOR SETTING BACK TO ZERO:

Place push piece on plate in position as shown in photograph, with hole in push piece over post in plate.

C. FUNCTION OF PUSH PIECE FOR SETTING BACK TO ZERO:

The function of this push piece is to move the flyback lever in toward the center of the watch each time the push piece is pushed.

REFERENCE: Flyback lever is Assembly 7.

REMARKS:

This type of chronograph with the minute register hand attached at the center of the chronograph is known as the 'center register'.

In this type of chronograph, the minute register wheel starts the minute register hand to turn at the instant the chronograph button is pushed to start the chronograph. The minute register hand will continue to advance in a steady, even manner as long as the chronograph mechanism is in operation. This steady even progress of the minute register hand is due to minute register wheel being attached to the center pivot of the watch.

This movement of the minute register hand in the 'center register' type is different from the movement of the minute register hand in the 'semi-instantaneous' type of chronograph.

In the 'semi-instantaneous' type of chronograph, the minute register hand is stationary until about the 58th second of registration. Between the 58th and 60th second of registration, the minute register hand moves forward very slowly, at the 60th second of registration the minute register hand will move forward very quickly to complete the registration of one minute on the dial.

The 'center register' type of chronograph was patented in 1889 and was more widely used 40 or 50 years ago than it is today. The 'semi-instantaneous' type is by far the most popular type of chronograph in use today.

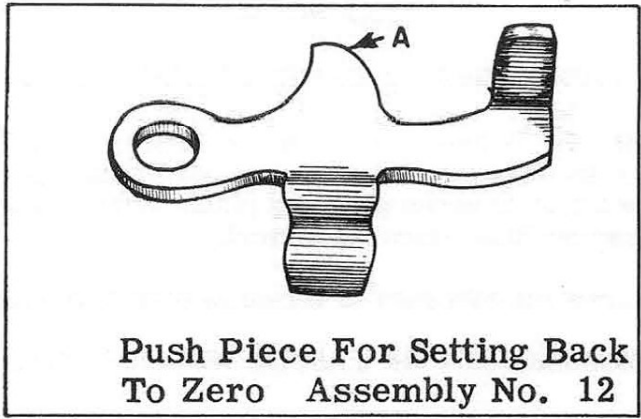

OILING

The post that the push piece for setting back to zero pivots on should be slightly moistened with oil.

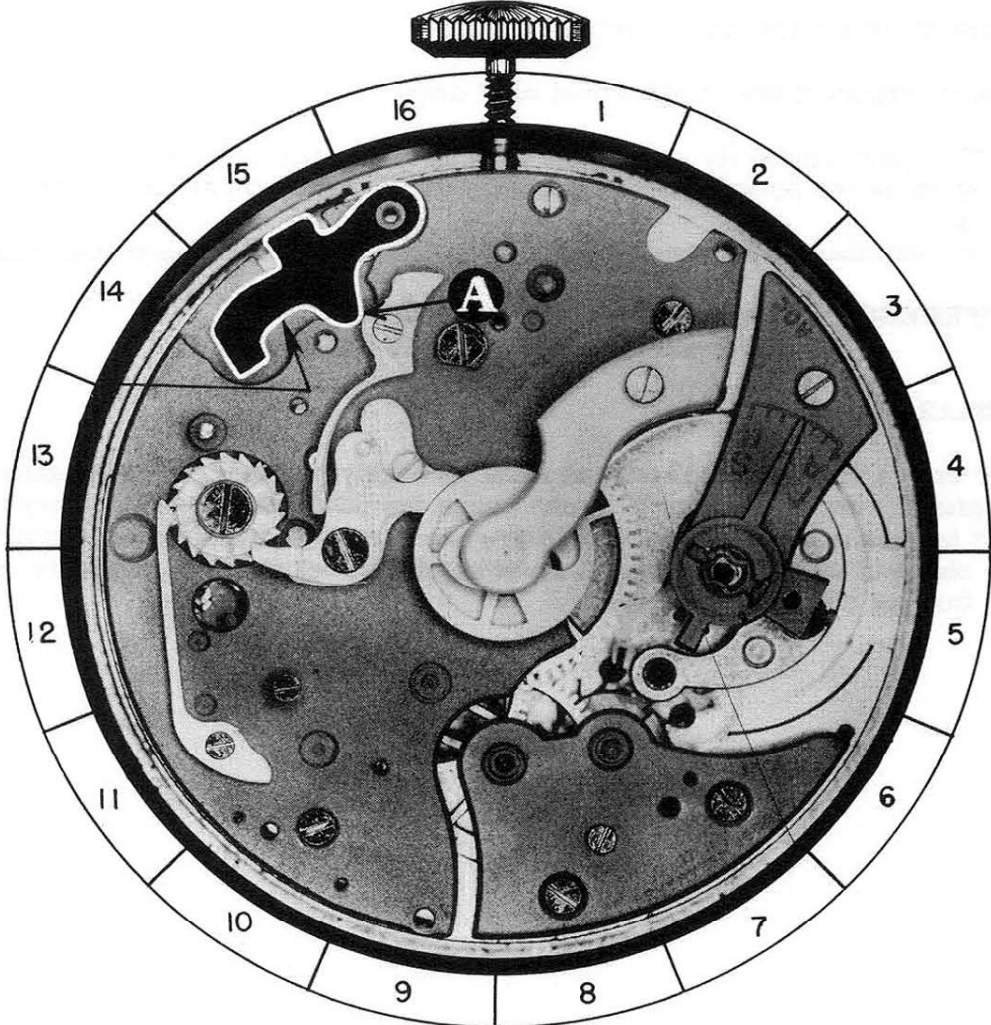

12-A

PART NO. 13

A. DISASSEMBLY PROCEDURE OF CASTLE WHEEL PAWL:

The castle wheel pawl is held in place by beveled countersink screw BS-4 and steady pins. Remove screw and loosen pawl from plate by sliding a thin blade screwdriver between pawl and plate. After steady pins are free in plate, pawl may be lifted from movement.

(The shape of screw for this part is shown at bottom of page)

B. HAZARDS IN DISASSEMBLY OF CASTLE WHEEL PAWL:

When removing pawl hold finger over pawl to prevent loss of pawl or screw.

C. ASSEMBLY PROCEDURE OF CASTLE WHEEL PAWL:

Place the castle wheel pawl on plate with steady pins over proper holes in plate. Before pressing pawl down to proper place, be sure end 'A' of pawl is not on top of ratchet teeth 'B' on castle wheel, but between two teeth on this wheel. Now press pawl down to proper place and replace beveled countersink screw BS-4 to hold this part in place.

D. FUNCTION OF CASTLE WHEEL PAWL:

The functions of the castle wheel pawl are:

1. This pawl correctly spaces the turning of the castle wheel. This eliminates the possibility of the castle wheel setting at an incorrect position.
2. It holds the castle wheel in the correct position until it is moved manually.

REFERENCE: Castle wheel is Assembly 14
Castle wheel ratchet teeth is Assembly 14B

REMARKS:

The end 'A' of castle wheel pawl must be highly polished. Any roughness or pits of rust at this location may cause the pawl not to function properly. If it is necessary to polish this part, care should be taken not to change the shape of end 'A' of pawl. It must be of correct shape to properly space the turning of the castle wheel.

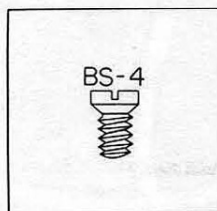

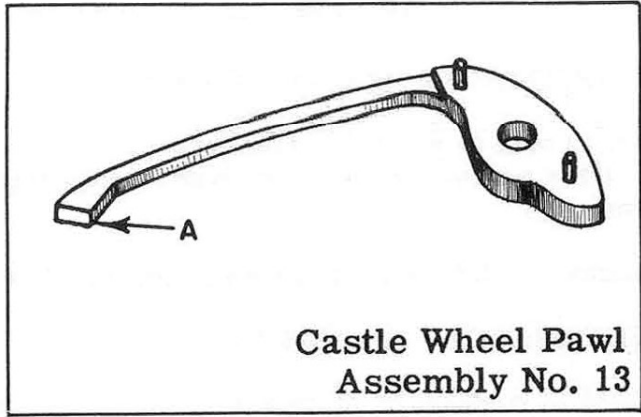

OILING

The castle wheel pawl should not be oiled.

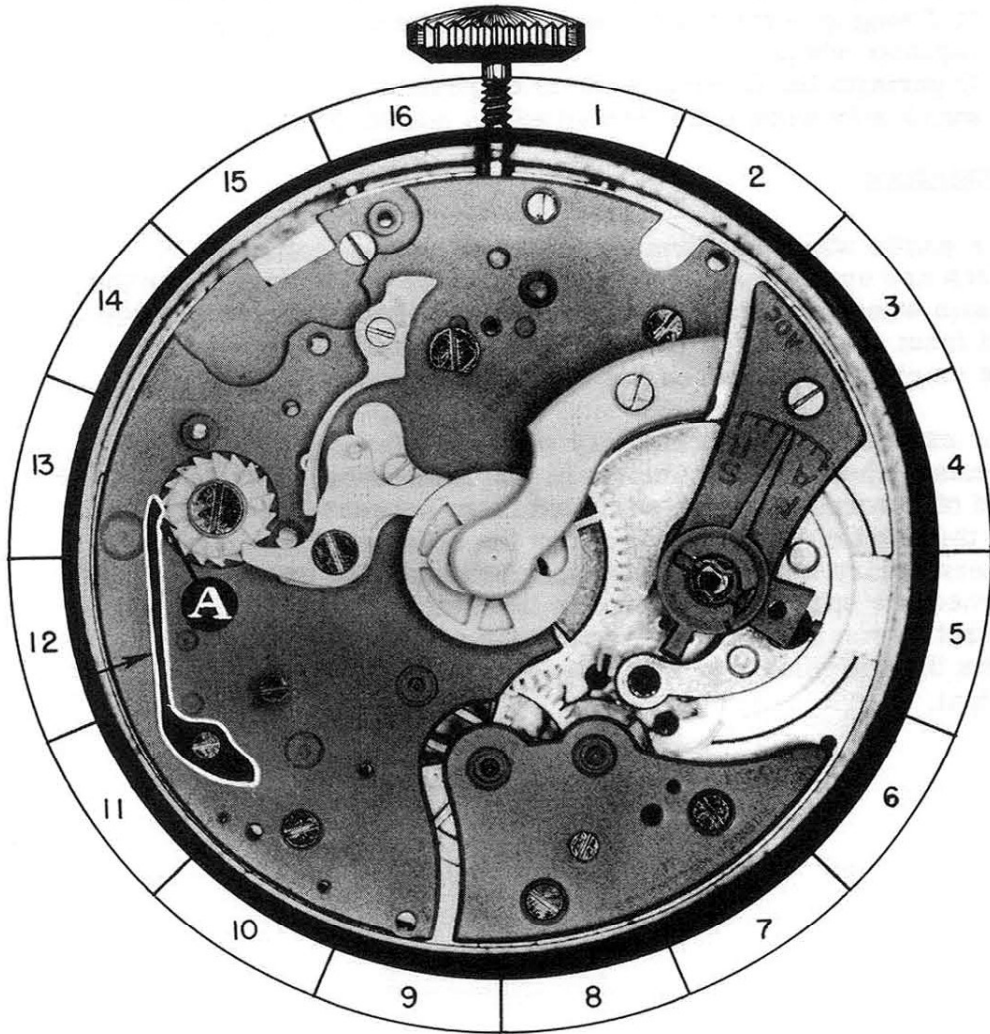

13-A

PART NO. 14

A. DISASSEMBLY PROCEDURE OF CASTLE WHEEL:

The castle wheel is held in place by shouldered screw SS-5 and pivots on this screw. After screw has been removed, castle wheel may be lifted from movement.

(The shape of screw for this part is shown at bottom of page)

B. ASSEMBLY PROCEDURE OF CASTLE WHEEL:

Place castle wheel in position on plate and replace shouldered screw SS-5 that holds castle wheel in place. Check to see that castle wheel turns freely under head of screw and yet does not have excessive end-shake or sideshake.

C. FUNCTION OF CASTLE WHEEL:

The functions of the castle wheel are:

1. It disengages the intermediary wheel from the seconds wheel.
2. It disengages the brake levers from the seconds wheel and minute register wheel.
3. It permits the flyback lever to be pushed in toward the center of watch only when the chronograph is not registering.

REMARKS:

The castle wheel performs its function by the 'columns' "A" which are evenly spaced around the center of the wheel. As the castle wheel is turned the column either forces a part to move out from the center of castle wheel or permits it to move into the empty space between the two columns.

For example, the intermediary wheel is disengaged from the seconds wheel by the columns of the castle wheel forcing the end of chronograph pivoted detent from between the columns until the point of this lever rests on the column. To engage the intermediary wheel with the seconds wheel, the castle wheel is turned one space. This permits the end of chronograph pivoted detent to enter the empty space between the columns which permits the two wheels to be engaged by the chronograph pivoted detent.

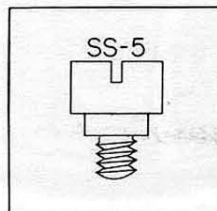

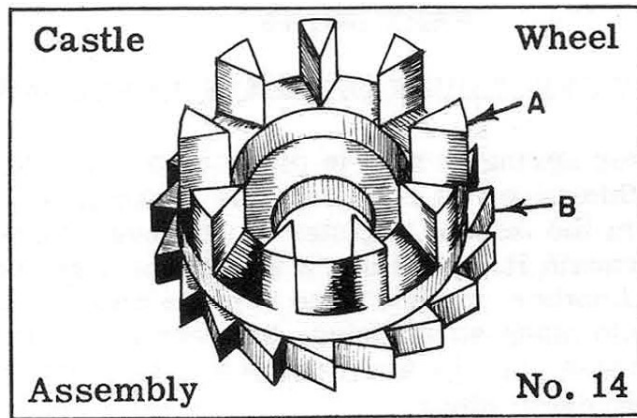

OILING

The castle wheel should be slightly moistened with oil at these points:

1. The shoulder of screw that castle wheel pivots on.
2. The columns "A" that contacts parts of this mechanism.
3. The ratchet teeth "B"

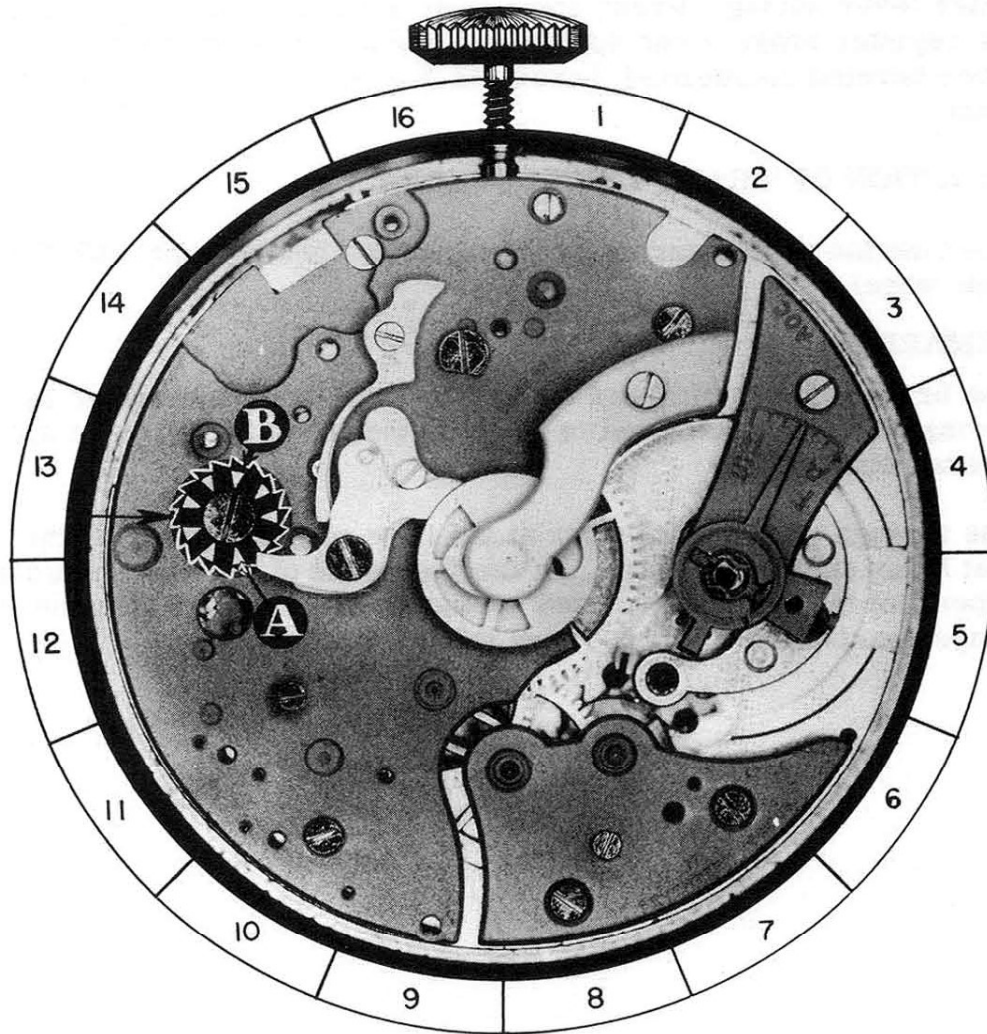

14 -A

PART NO. 15

A. DISASSEMBLY PROCEDURE OF BRAKE LEVER SPRING:

The brake lever spring is held in place by beveled countersink screw BS-5. After this screw is removed, the brake lever spring may be separated from the minute register brake lever spring, which lies directly underneath it, by sliding a thin blade screwdriver between the springs. Another method is to remove both springs at once by sliding a thin blade screwdriver between lower spring and plate. After these springs are removed from plate, they may be separated from each other.

(The shape of screw for this part is shown at bottom of page.)

REFERENCE: Minute register brake lever spring is Assembly 16.

B. ASSEMBLY PROCEDURE OF BRAKE LEVER SPRING:

Place the steady pins in this part in proper holes in minute register brake lever spring. Press down until these pins pass through minute register brake lever spring into proper holes in plate. Now replace beveled countersink screw BS-5 which holds these springs in place.

C. FUNCTION OF BRAKE LEVER SPRING:

The function of this spring is to engage the brake lever with the seconds wheel.

REMARKS:

The brake lever spring and the minute register wheel brake lever spring should be examined to see that the free ends of these springs are not binding.

The springs are held together at the base of each spring by the screw that holds springs in place, but the free ends of springs should be independent of each other. Each spring should hold a tension on the proper part without interference from the other spring.

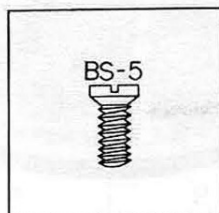

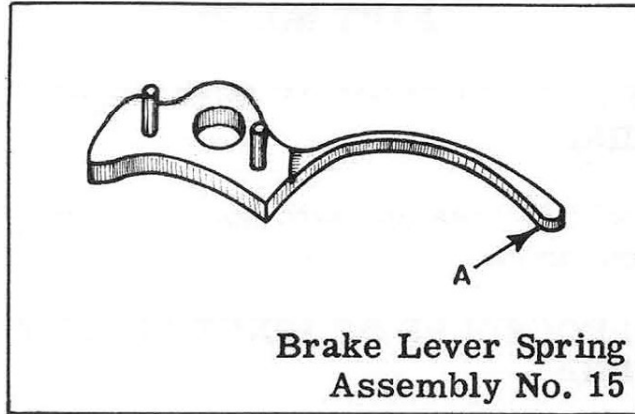

Brake Lever Spring
Assembly No. 15

OILING

End "A" of brake lever spring should be slightly moistened with oil at point of contact with brake lever.

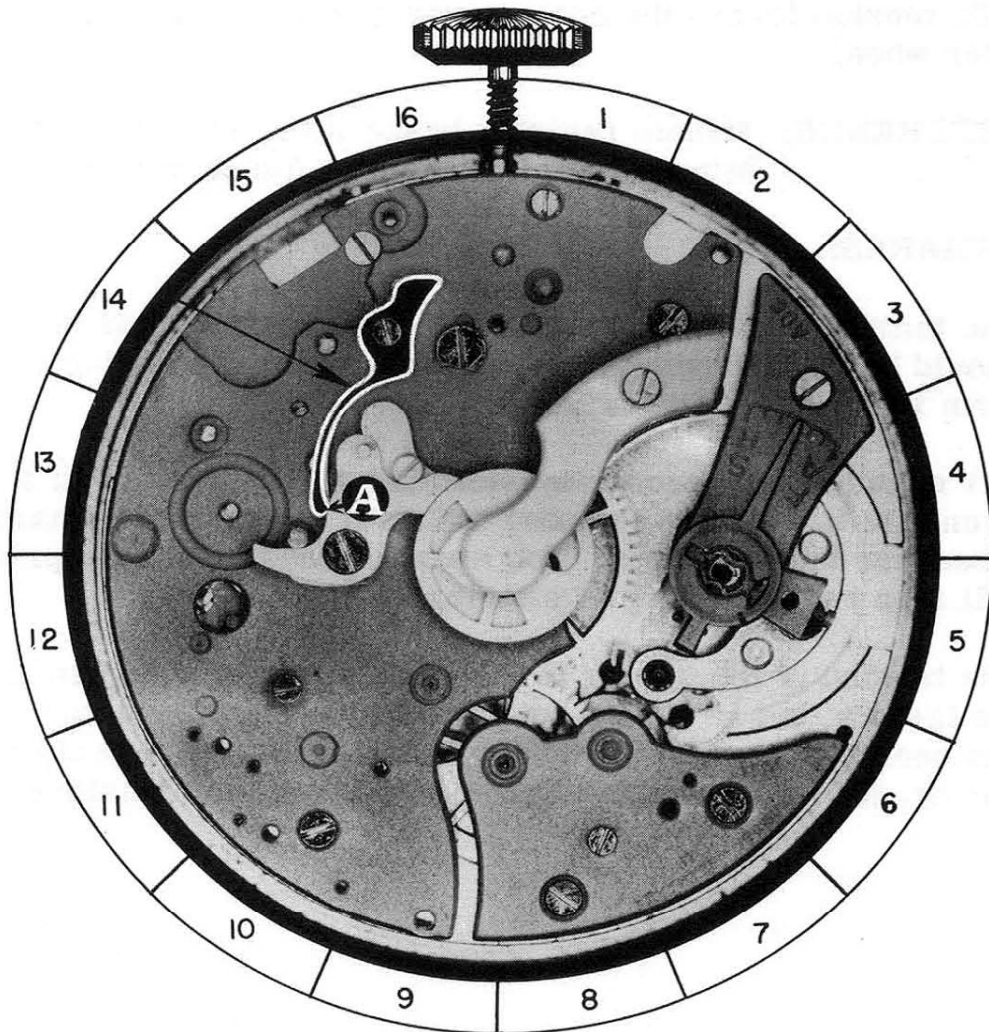

15-A

PART NO. 16

A. DISASSEMBLY PROCEDURE OF MINUTE REGISTER BRAKE LEVER SPRING:

This spring will be free on plate due to it being held in place by the previous part.

B. ASSEMBLY PROCEDURE OF MINUTE REGISTER BRAKE LEVER SPRING:

Place the minute register brake lever spring in position on plate as shown in photograph. This part is held in place by the next part to be assembled.

C. FUNCTION OF MINUTE REGISTER BRAKE LEVER SPRING:

This spring holds a tension on the minute register brake lever. This tension forces the brake lever to contact the minute register wheel.

REFERENCE: Minute register brake lever is Assembly 18
Minute register wheel is Assembly 22.

REMARKS:

The tension that any spring in the chronograph holds on a part should be no stronger than is necessary for the spring to perform its function properly.

For example, any excess tension that a spring holds on a part to engage it with another part makes it unnecessarily hard to disengage the two parts. Too strong a tension of the spring will also cause excessive wearing of parts.

The tension of the spring to the part is properly adjusted by the factory, but in case a spring must be made or a spring has been replaced by another watchmaker, when adjusting a spring, the above remarks should be taken into consideration.

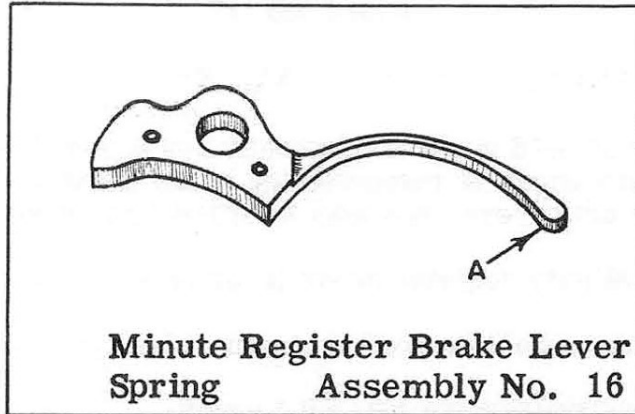

OILING

End "A" of minute register brake lever spring should be slightly moistened with oil at point of contact with minute register brake lever.

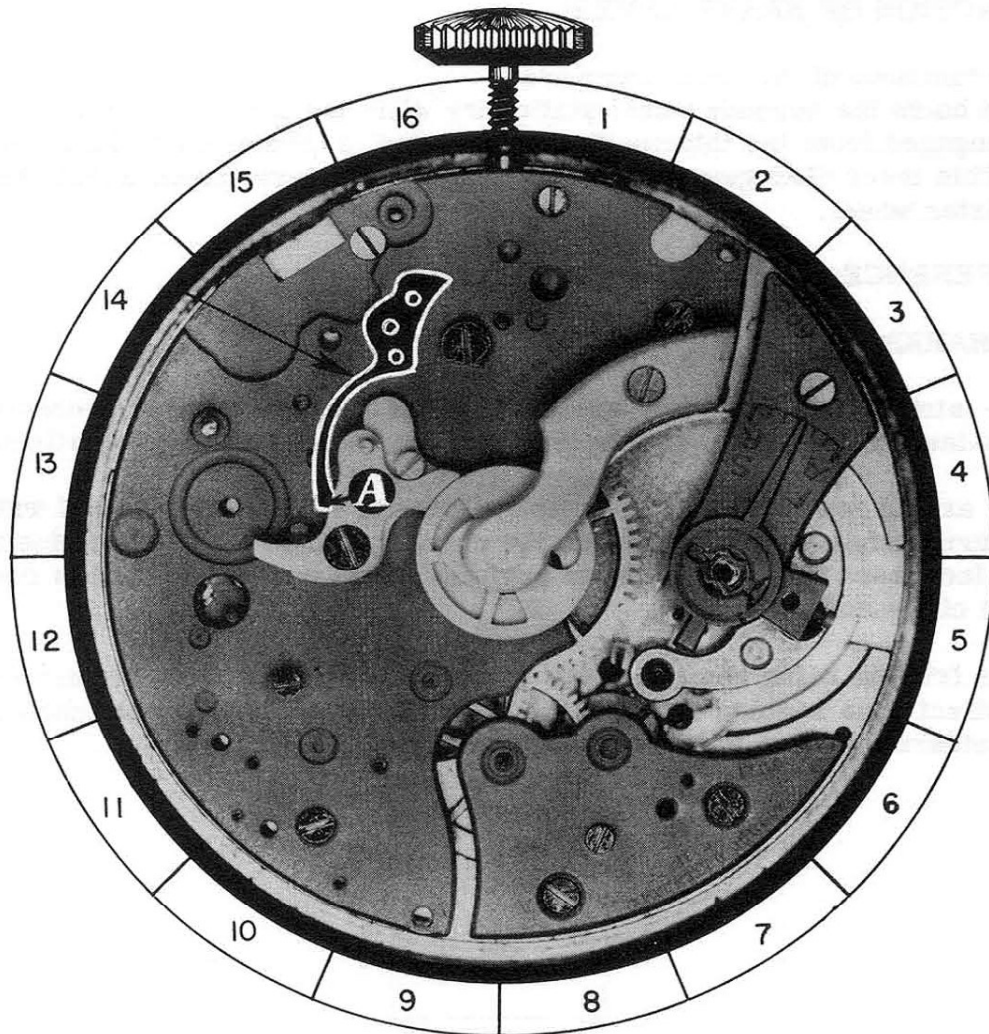

16-A

PART NO. 17

A. DISASSEMBLY PROCEDURE OF BRAKE LEVER:

The brake lever is held in place by shouldered screw SS-6 and pivots on this screw. When screw is removed, the brake lever will be free on the minute register brake lever and may be lifted from movement.

REFERENCE: Minute register brake lever is Assembly 18.

(The shape of screw for this part is shown at bottom of page)

B. ASSEMBLY PROCEDURE OF BRAKE LEVER:

Place brake lever on the minute register wheel brake lever as shown in photograph. The end "A" of brake lever should be between the seconds wheel and eccentric stud "D" as shown in photograph. Now replace shouldered screw SS-6 which holds these parts in place. Check to see that these parts work freely under head of screw and the minute register brake lever works freely under the brake lever.

C. FUNCTION OF BRAKE LEVER:

The functions of the brake lever are:

1. It holds the seconds wheel stationary when the seconds wheel is disengaged from the intermediary wheel and is free of the flyback lever.
2. This lever disengages minute register brake lever from minute register wheel.

REFERENCE: Flyback lever is Assembly 7.

REMARKS:

The minute register brake lever should not hold any greater pressure on minute register wheel than is necessary to hold the wheel stationary.

Any excess pressure on this wheel will cause the center wheel of watch to turn unnecessarily hard when the chronograph is disengaged, due to the increased friction of minute register wheel post on the hollow center post of the center wheel.

This friction being applied at the center of watch will probably not greatly affect time keeping of the watch, nevertheless, it should be taken into consideration when adjusting the chronograph.

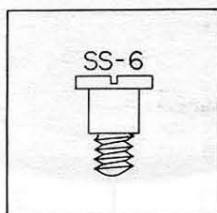

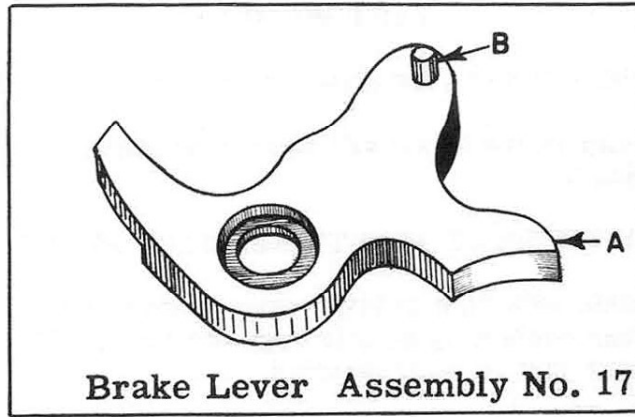

OILING

The shoulder of screw that the brake lever pivots on should be slightly moistened with oil.

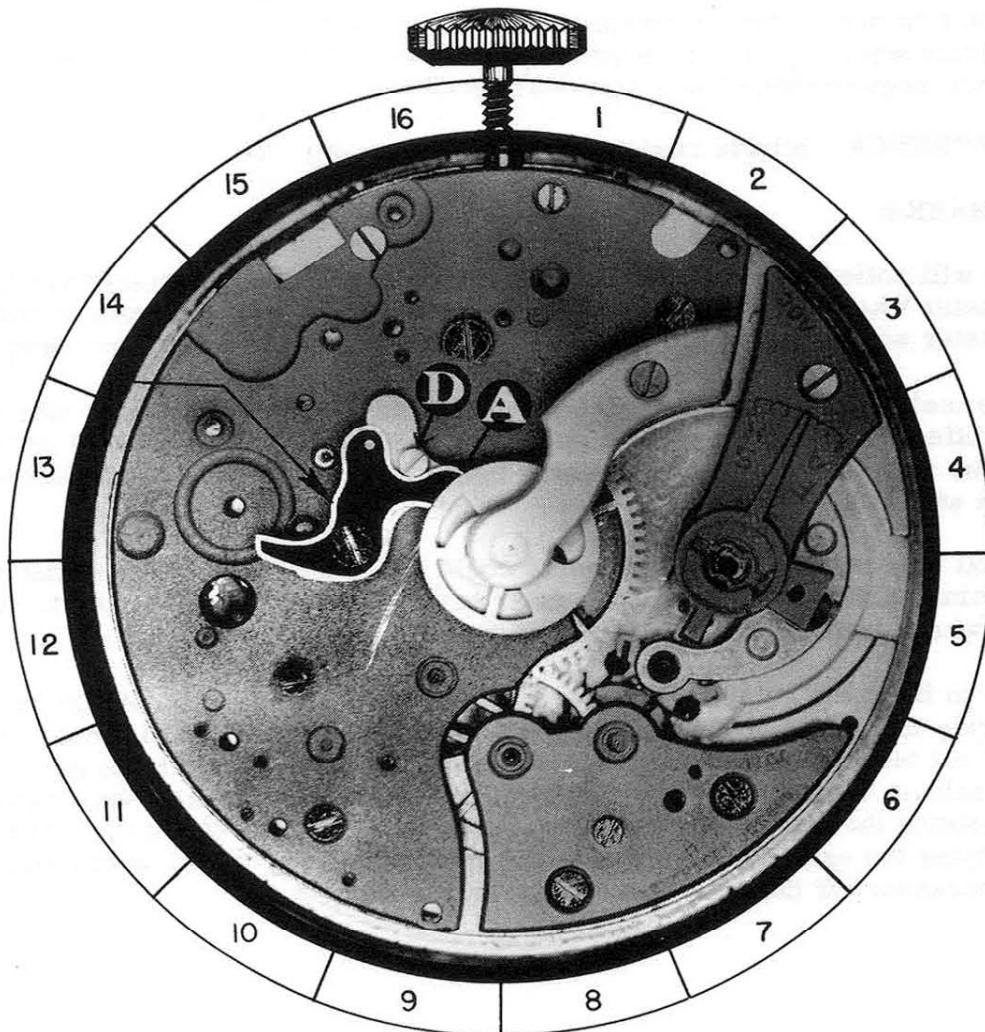

17-A

PART NO. 18

A. DISASSEMBLY PROCEDURE OF MINUTE REGISTER BRAKE LEVER:

The minute register brake lever will be free on plate, as it was held in place by the previous part.

B. ASSEMBLY PROCEDURE OF MINUTE REGISTER BRAKE LEVER:

Place lever on plate with hole in lever over proper hole in plate, with end "A" of brake lever contacting minute register wheel. This part is held in position by the next part to be assembled.

C. HAZARDS IN ASSEMBLY OF MINUTE REGISTER BRAKE LEVER:

The minute register brake lever should be carefully examined for any roughness or pits of rust. This part works between the plate and seconds wheel brake lever. These parts must be smooth to permit this lever to function properly.

D. FUNCTION OF MINUTE REGISTER BRAKE LEVER:

When this brake lever is permitted to engage with the minute register wheel by the chronograph mechanism, this lever holds the minute register wheel in a stationary position.

REFERENCE: Minute register wheel is Assembly 22.

REMARKS:

You will notice that the end "A" of brake lever where it contacts minute register wheel has teeth on it. These teeth engage with the teeth on minute register wheel to hold the wheel stationary when these parts are engaged.

The teeth on the brake lever and the teeth on the minute register wheel are of different sizes. These are purposely made this way to prevent turning of the minute register wheel as the brake lever is brought in contact with this wheel.

Equal size teeth on these two parts could cause an error in the registration of minutes due to the minute register brake lever turning the minute register wheel until the teeth are fully engaged.

Due to the teeth being a different size, the teeth do not fully engage but merely the points of the teeth engage, which hold the wheel stationary but will not turn the minute register wheel when the brake lever engages with the minute register wheel. The teeth on these two parts provide a means of holding the minute register wheel stationary without the brake lever applying the extreme pressure to the minute register wheel which would be necessary if these teeth were not on these parts.

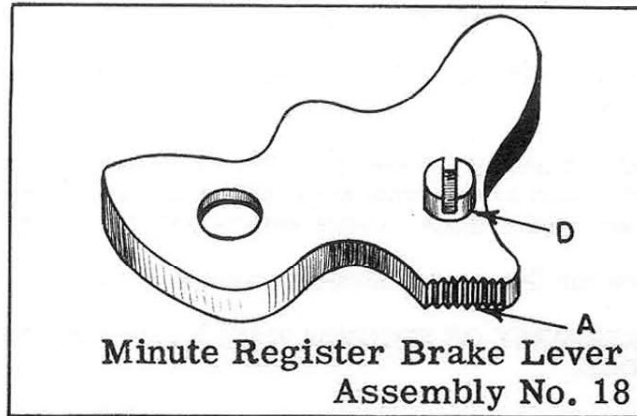

OILING

The shoulder of screw that minute register brake lever pivots on should be slightly moistened with oil.

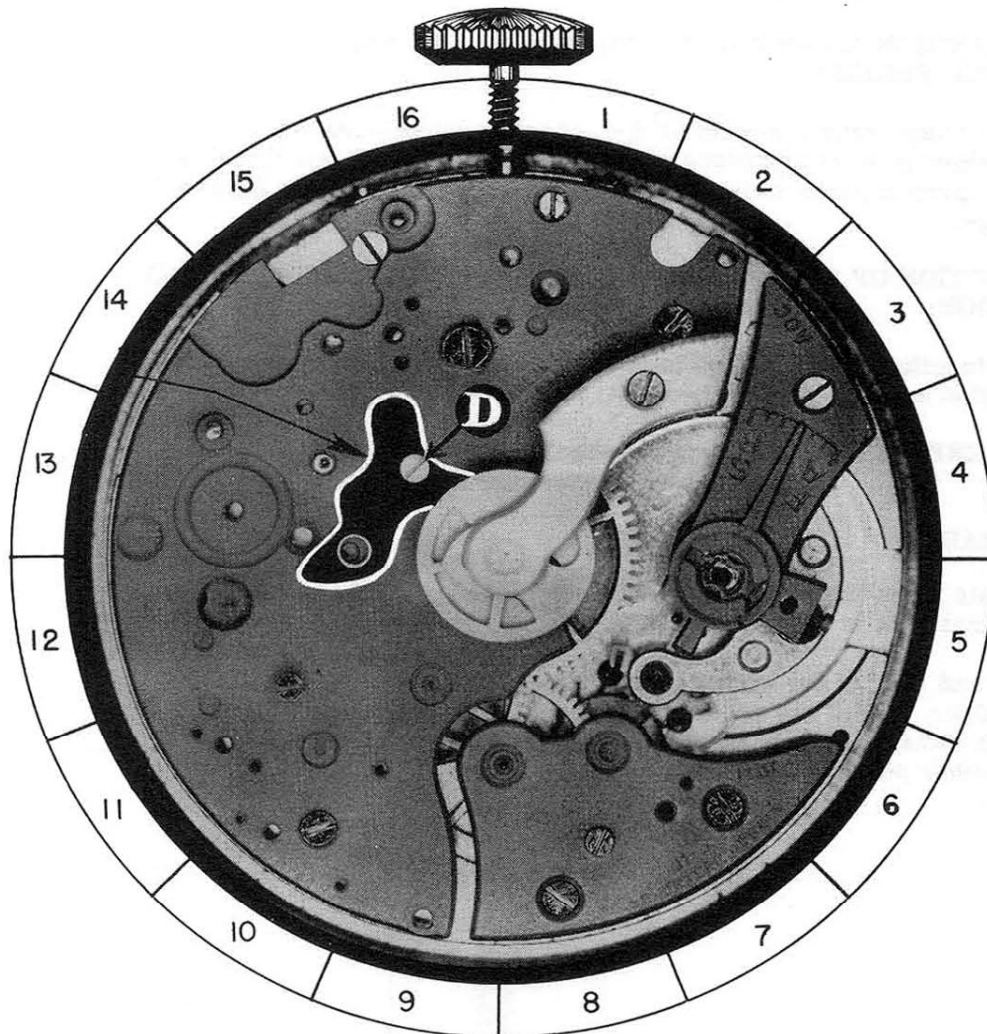

18-A

PART NO. 19

A. DISASSEMBLY PROCEDURE OF SECONDS WHEEL AND MINUTE REGISTER WHEEL BRIDGE:

This bridge is held in place by fillister head screw FS-2 and steady pins. Remove screw and loosen bridge from plate with a thin blade screwdriver. When steady pins are free in plate, bridge may be lifted from movement.

(The shape of screw for this part is shown at bottom of page)

B. HAZARDS IN DISASSEMBLY OF SECONDS WHEEL AND MINUTE REGISTER WHEEL BRIDGE:

When loosening bridge from plate, avoid any twisting of bridge as this may damage the pivot on seconds wheel or chip the jewel in bridge.

C. ASSEMBLY PROCEDURE OF SECONDS WHEEL AND MINUTE REGISTER WHEEL BRIDGE:

Place bridge on plate with steady pins over proper holes in plate. Place top pivot of seconds wheel so it will enter the jewel in bridge. Bridge may now be pressed in proper place with back of tweezers and fillister head screw FS-2 replaced.

D. HAZARDS IN ASSEMBLY OF SECONDS WHEEL AND MINUTE REGISTER WHEEL BRIDGE:

Before tightening screw in bridge, check to make sure that minute register wheel is in proper place on center wheel post. If this wheel is not in its proper place when bridge is tightened, it may break the jewel in bridge.

E. FUNCTION OF SECONDS WHEEL AND MINUTE REGISTER WHEEL BRIDGE:

The function of this bridge is to hold the top pivot of seconds wheel in position so the seconds wheel will function properly.

REFERENCE: Minute register wheel is Assembly 22.
Seconds wheel is Assembly 20.

REMARKS:

At this point, the seconds wheel tension spring should be checked to see that it is in correct position.

The end "A" of the seconds wheel tension spring should be on the shoulder "E" of the seconds wheel post. The spring should not touch either the seconds wheel or the minute register wheel at any other point.

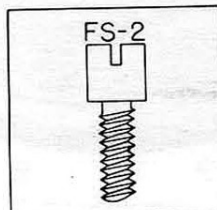

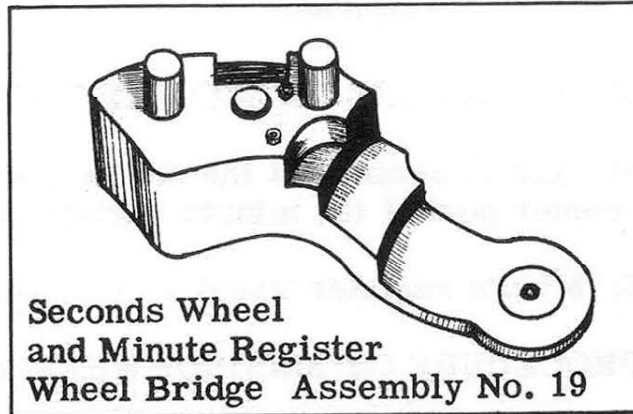

Seconds Wheel
and Minute Register
Wheel Bridge Assembly No. 19

OILING

The pivot in the jewel in this bridge should be oiled as you would properly oil a train pivot in a watch.

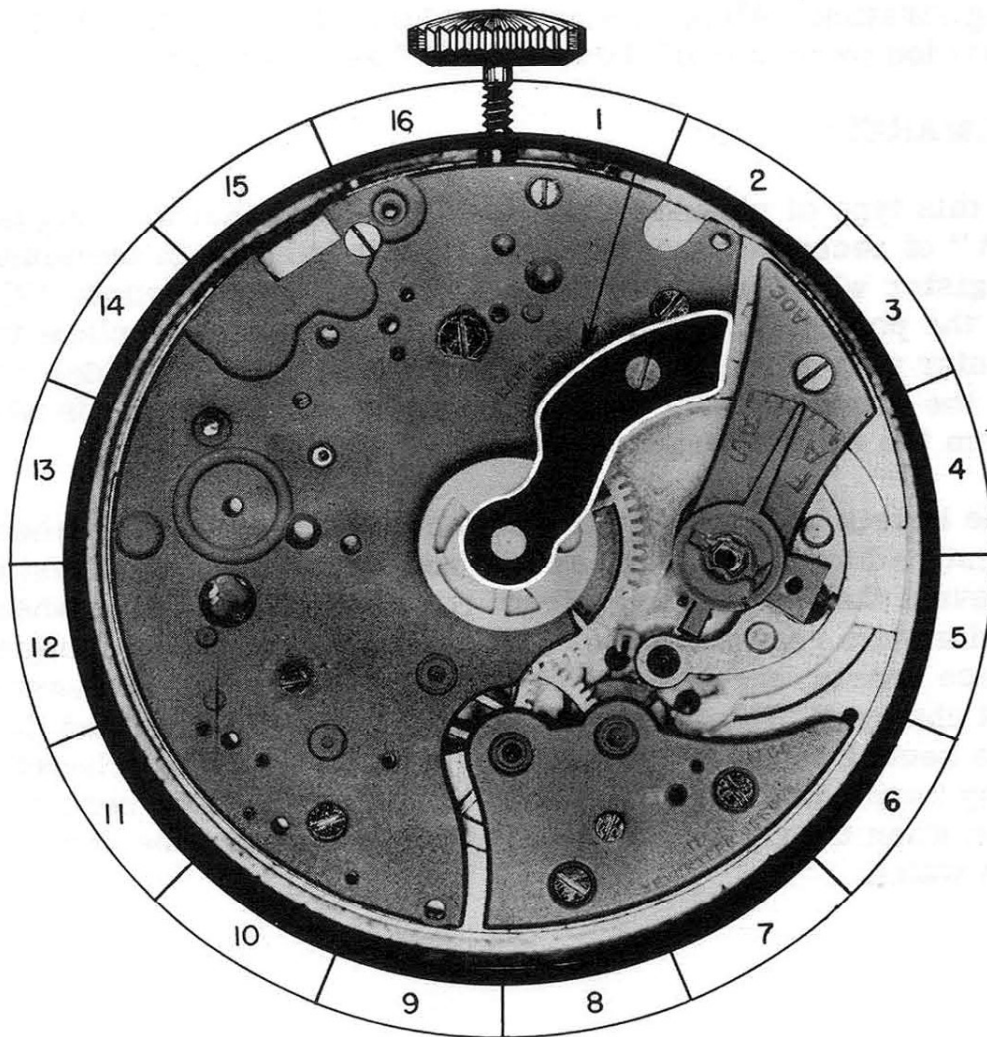

19-A

PART NO. 20

A. DISASSEMBLY PROCEDURE OF SECONDS WHEEL:

To remove this wheel, simply lift the seconds wheel post out of the hollow center post of the minute register wheel.

REFERENCE: Minute register wheel is Assembly 22.

B. ASSEMBLY PROCEDURE OF SECONDS WHEEL:

To replace the seconds wheel, place the long post "A" down in hollow center post of minute register wheel.

C. FUNCTION OF SECONDS WHEEL:

The function of this wheel is to register the number of seconds on the dial that have elapsed since the beginning of the registration. Also, this wheel returns the hand to a zero position by means of the heart "B" attached to it.

REMARKS:

In this type of chronograph, you will notice that the long post "A" of seconds wheel does not fit in a bushing in the minute register wheel post, but there is a small protuberance "C" on the post, which holds the seconds wheel post in place in the center post of the minute register wheel. The shoulder "D" on the seconds wheel post properly spaces the seconds wheel from the minute register wheel.

The hearts on the seconds wheel and minute register wheel must be highly polished, as any roughness or pits of rust may prevent the flyback lever from returning the seconds wheel and minute register wheel to a zero position. When polishing these hearts, care should be taken that the shape of heart is not changed. These hearts should be tested to see that they are secure to the wheels, as any looseness of these hearts may result in one of the wheels not returning to a zero position when the flyback lever is pushed in toward the center of the watch.

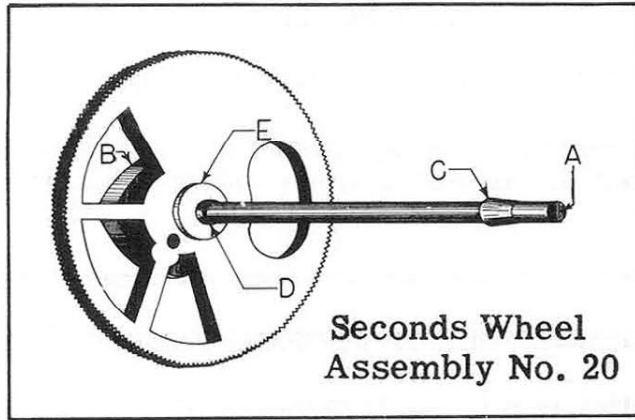

OILING

The top pivot on the seconds wheel should be oiled after bridge for this part is placed in watch. The bottom pivot should not be oiled.

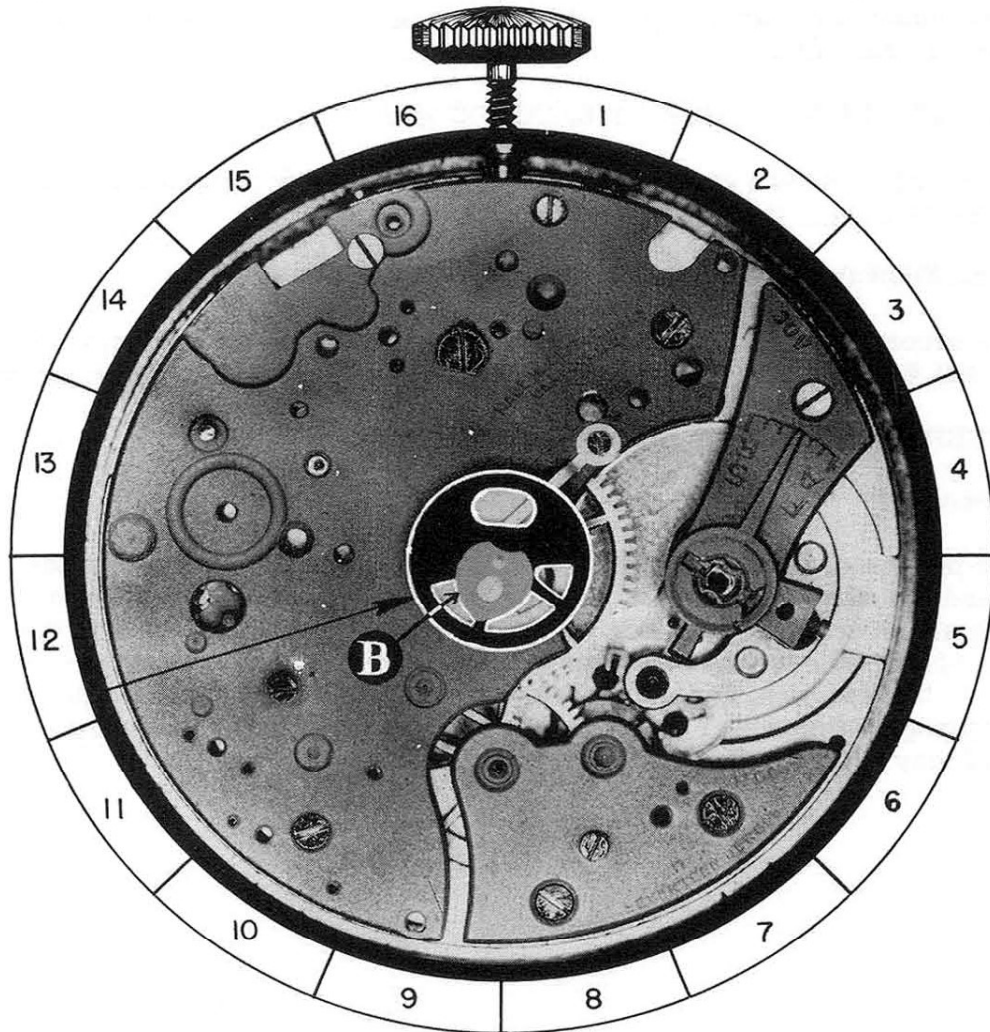

20-A

PART NO. 21

A. DISASSEMBLY PROCEDURE OF SECONDS WHEEL TENSION SPRING:

This spring is held in position by beveled countersink screw BS-6. After screw is removed, spring will be free on plate and may be lifted from movement.

(The shape of screw for this part is shown at bottom of page)

B. HAZARDS IN DISASSEMBLY OF SECONDS WHEEL TENSION SPRING:

This tension spring is very easily damaged and must be of correct shape to function properly. Handle carefully when removing so as not to bend the spring.

C. ASSEMBLY PROCEDURE OF SECONDS WHEEL TENSION SPRING:

The tension spring is placed with hole in spring over proper hole in plate. Be sure spring is right side up, as the highly polished end "A" of spring should be up. Now replace beveled countersink screw BS-6, but before tightening screw, make sure that end "A" of spring is not over center hole far enough to touch post of seconds wheel when this wheel is replaced.

D. HAZARDS IN ASSEMBLY OF SECONDS WHEEL TENSION SPRING:

This spring is very easily bent. Handle carefully when replacing so as not to change the shape of spring.

E. FUNCTION OF SECONDS WHEEL TENSION SPRING:

The seconds wheel tension spring holds a tension on the seconds wheel so that it turns with an even action with no irregular jumping or jerking.

REFERENCE: Seconds wheel is Assembly 20.

REMARKS:

The tension of the spring on the seconds wheel must be properly adjusted, so when the watch is running, the second hand advances one-fifth of a second for each beat of the watch. Too strong a tension of this spring on seconds wheel may cause this wheel to be unnecessarily hard to turn, and may cause the watch to stop. If the tension of spring on this wheel is not strong enough, turning of the seconds hand may be irregular.

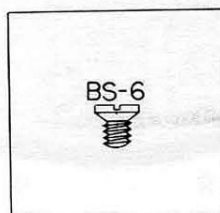

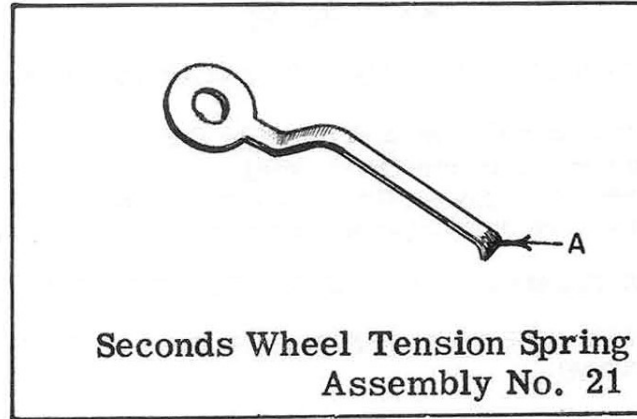

OILING

The seconds wheel tension spring should not be oiled.

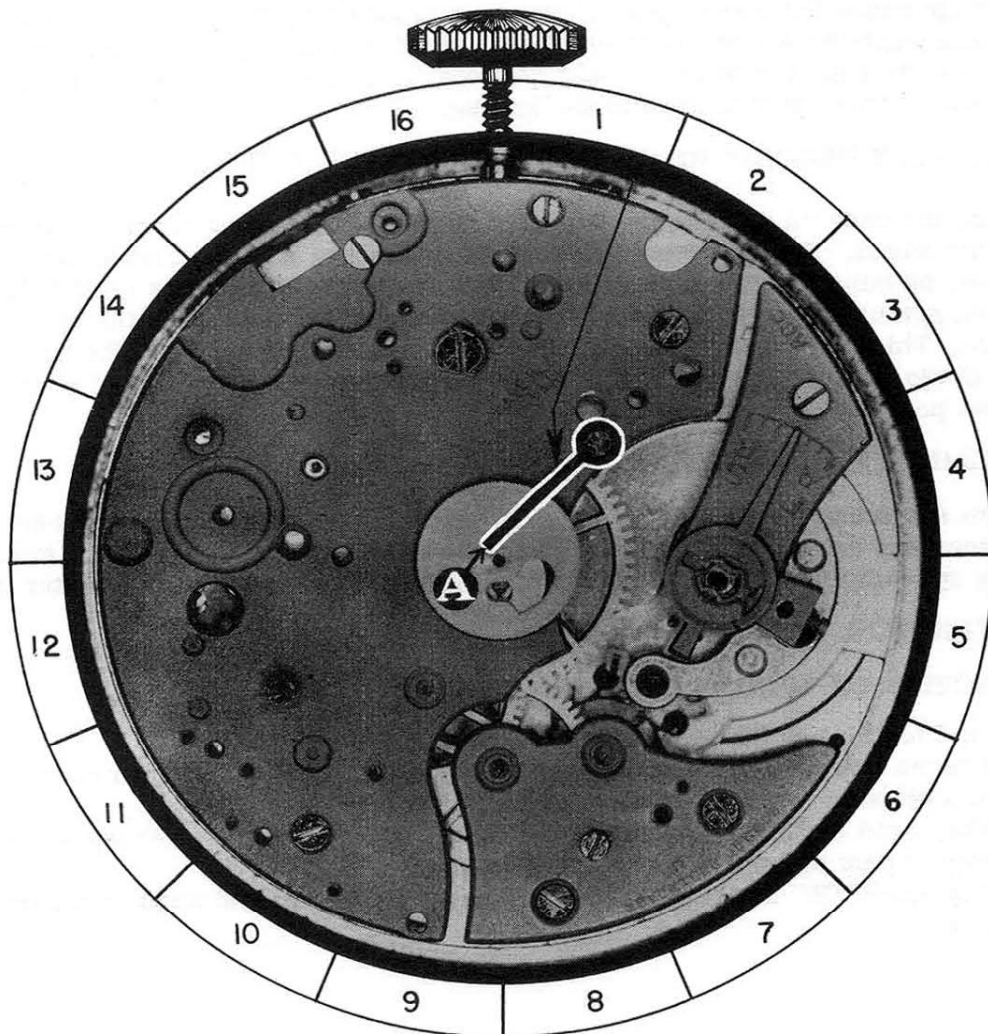

21-A

PART NO. 22

A. DISASSEMBLY PROCEDURE OF MINUTE REGISTER WHEEL:

The minute register wheel is held in place by the branches of spring "C" and "D" as shown on the isometric drawing. To remove the minute register wheel, lift the wheel straight up, this will remove the spring from the center wheel post, and the long post on wheel from the hollow center pinion.

B. HAZARDS IN DISASSEMBLY OF MINUTE REGISTER WHEEL:

Be sure to lift wheel straight up to prevent damage to the long post "A" on minute register wheel.

REMARKS:

The long post "A" on the minute register wheel has two small protuberances "E" on which are slightly larger than the diameter of the post. This holds the post "A" in proper position in the hollow center pinion.

The branches of driving spring shown as "C" and "D" on the isometric drawing fit over the outside of the center post which extends above the plate. These branches of spring "C" and "D" fit in a small groove in the center post to hold the minute register wheel in position and the friction of these springs cause the center post to turn the minute register wheel when the minute register wheel brake lever is free of minute register wheel. When the minute register wheel is held stationary by the brake lever, this spring permits center post to turn in the spring.

C. ASSEMBLY PROCEDURE OF MINUTE REGISTER WHEEL:

Place the post "A" of minute register wheel in the hollow center post of the center wheel. Hold the wheel down with finger and with a suitable size screw-driver passing through hole in wheel and through hole in heart until it is between springs, pull back slightly toward screw "F" that holds the spring in place. This will spread the branches "C" and "D" of spring. The spreading of the spring will permit the spring to pass over the outside of center wheel post and into groove in this post.

D. HAZARDS IN ASSEMBLY OF MINUTE REGISTER WHEEL:

When spreading the ends "C" and "D" of driving spring, do not spread springs any further than necessary to place this spring in position. Any excess spreading may lose the desired adjustment of spring to the center post.

REFERENCE: Minute register brake lever is Assembly 18.

E. FUNCTION OF MINUTE REGISTER WHEEL:

The functions of the minute register wheel are:

1. It turns the minute register hand to register on the dial the number of minutes elapsed since the beginning of the registration.
2. When held stationary by the brake lever, the minute register wheel permits center post to turn in the driving spring.
3. The heart "B" attached to wheel returns the wheel and hand to a zero position.

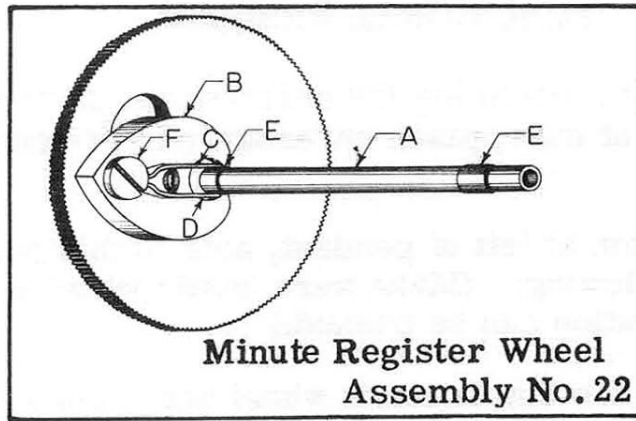

OILING

The minute register wheel should not be oiled.

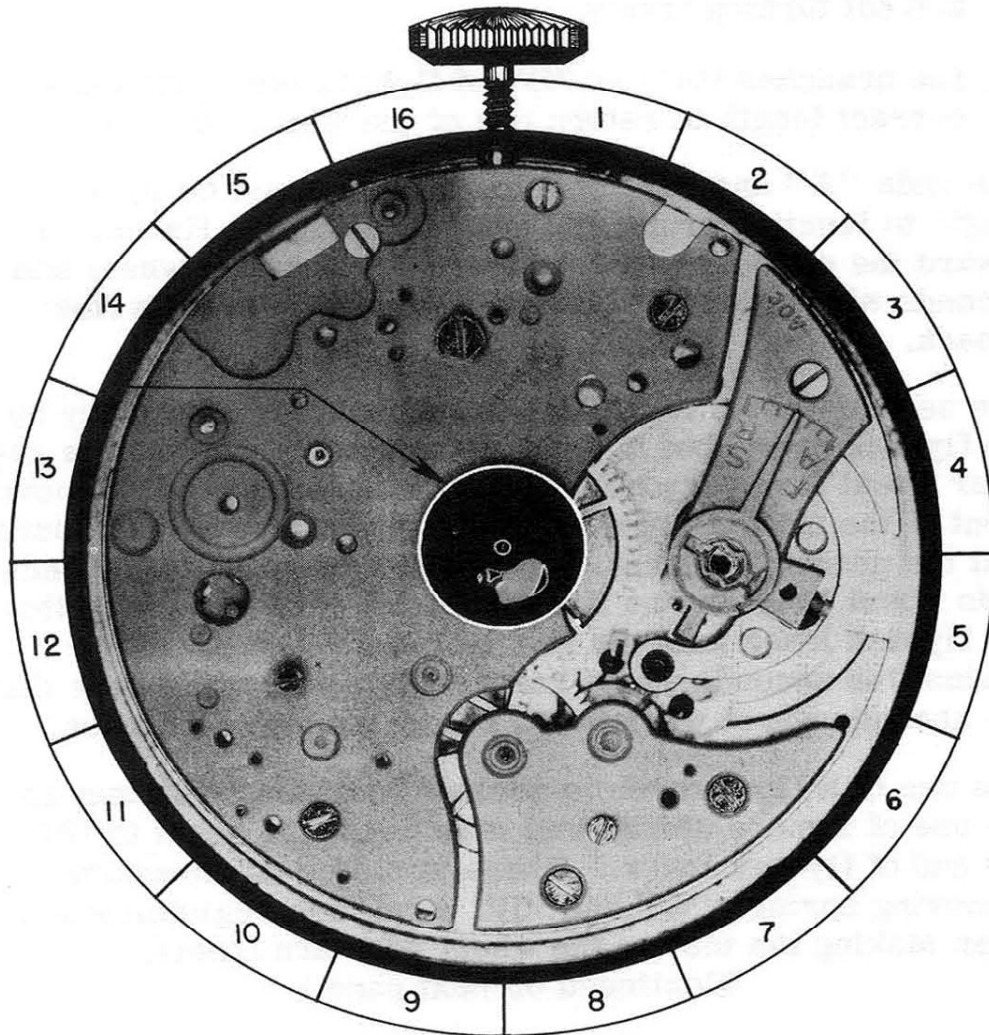

22-A

FUNCTIONAL RESULTS

After completely assembling the chronograph with the exception of the back of case, place chronograph in front of you, pendant up.

1. Push the button at left of pendant, hold in this position, and check the following: (Make sure castle wheel is in proper position so button can be pushed.)
 - A. Check to see that seconds wheel and minute register wheel return the hands to a zero position.

CORRECTION: The following errors may prevent these hands from returning to a zero position:

1. Loose hands or hands not being set correctly.
2. The minute register wheel or the seconds wheel binding and not turning freely
3. The branches "A" or "B" of flyback lever not being of correct length to return one of the wheels to zero.

The ends "A" and "B" of flyback lever must be the correct length to function properly. While holding the flyback in toward the center of watch, the minute register wheel and seconds wheel should be checked for turning with a fine broach.

The seconds wheel should be held absolutely stationary by the flyback lever, but it is an advantage that the minute register wheel turn very slightly. The advantage of this movement of the minute register wheel is that it will make sure that the greatest amount of pressure is applied to the seconds wheel heart by the flyback lever. It is important that the flyback lever hold the greatest amount of pressure against the seconds wheel heart as this will make sure that the seconds wheel will always return to a zero position.

The use of a fine broach is advised in making this test as the use of a more sturdy tool may cause the heart to lift the end of flyback lever. There would be an advantage in removing springs "C" and "D" on minute register wheel when making the test so the wheel will turn freely.

(Continued on next page.)

2. Release button at left of pendant. Then push button at right of pendant, release it, and check the following:

A. Check the depthing of teeth on intermediary wheel with teeth on seconds wheel. The following errors could prevent the proper depthing of these teeth:

1. Chronograph pivoted detent spring not holding enough tension on chronograph pivoted detent.

2. Chronograph pivoted detent binding and not turning freely.

3. Improperly adjusted eccentric studs may prevent proper depthing of these teeth. (See adjusting of eccentric studs in front of book.)

B. Check to see that minute register brake lever is disengaged from minute register wheel.

CORRECTION: Improperly adjusted eccentric stud on brake lever may prevent disengagement of minute register brake lever from minute register wheel. (See adjustment of eccentric studs in front of book.)

C. Check to see that seconds hand moves forward in a steady manner with no irregular jumping or jerking.

CORRECTION: This irregular movement of seconds hand is usually caused by too weak a tension of seconds wheel tension spring on seconds wheel.

D. Check to see that minute register wheel moves forward in a steady even manner and yet the wheel should not be held too tightly to the center post of watch.

CORRECTION: The driving spring shown as "C" and "D" on isometric drawing of minute register wheel should be adjusted so the tension of this spring on the center post will be no stronger than is necessary to turn the minute register wheel with surity. Any excess tension of spring on center post will cause the center wheel to be unnecessarily hard to turn and may cause the watch to stop. (Continued on next page.)

3. Push button to right of pendant, release it, and check the following:

A. Check to see that seconds wheel brake lever is in contact with seconds wheel.

CORRECTION: The following errors may prevent the brake lever from contacting the seconds wheel:

1. Brake lever not turning freely under head of screw.

2. Brake lever spring not holding proper tension on brake lever.

B. Check to see that minute register brake lever is contacting the minute register wheel.

CORRECTION: The following errors may prevent the minute register brake lever from contacting the minute register wheel:

1. Minute register brake lever binding and not turning freely.

2. Minute register brake lever spring not holding proper tension on minute register brake lever.

3. Eccentric stud on minute register brake lever improperly adjusted. (See adjustment of eccentric studs in front of book.)

IDENTIFYING A CHRONOGRAPH OR STOP WATCH

The chronograph and stop watch are very similar in appearance in many respects, but there is a difference which will enable you to distinguish the chronograph from the stop watch.

The chronograph is a watch having at least one supplementary hand in addition to the regular hour, minute, and second hand which can be started, stopped or returned to zero at will. Thus the chronograph can be used as a regular timekeeping watch and may also be used in registering observations.

The stop watch is a watch which has only the necessary hands to register an observation, the hour, minute, and seconds hand being omitted. The stop watch is not used to indicate the time of day, but only to register the length of observations.

The stop watch is divided into two categories, the stop watch in which the balance wheel is continually in motion and the stop watch in which the balance wheel is in motion only during the actual timing of observations.

The advantage in the latter type is that the watch is running only during the actual timing operation. Thus there is less wear to the stop watch and the mainspring does not have to be wound so often. This is especially true in the stop watch which has a very rapid oscillation of the balance. The stop watch by altering the hairspring and balance wheel to increase the oscillation of the balance can be made to register $1/30$, $1/50$, or even $1/100$ of a second. This increase in the oscillation of the balance in the stop watch is possible because the balance wheel is in motion only during the actual timing operation and the watch does not indicate the time of day.

The chronograph is designed to register the time correct to $1/5$ of a second. It would be difficult to make a chronograph register correctly to less than $1/5$ of a second, as the rapid oscillation of the balance would require too large a mainspring to run the watch for a twenty-four hour period, and the hour and minute hand would have to be geared down tremendously to keep the correct time.

The chronograph usually embodies the basic principles by which the stop watch performs its function, and to anyone familiar with the functions of the various parts of a chronograph should have no trouble understanding stop watch mechanism.

THE TACHOMETER

- A. The tachometer is used to indicate the speed of an object in miles per hour. A tachometer can only indicate the average speed of an object traveling over a course of a measured mile.

METHOD OF USING TACHOMETER

1. Start chronograph sweep second hand at the exact moment the object starts to travel the measured distance of one mile.
2. When the object has traveled the course of one mile, stop the chronograph sweep second hand. The point on the tachometer scale where the sweep second hand stopped will indicate the average speed of the object in miles per hour.

SPLIT SECOND SCALE

- B. This scale is divided into 300 divisions, each indicating $1/5$ of a second. Every fifth division is marked with extra long lines denoting one second.

The main purpose of this scale is to measure a fraction of a second accurately.

MINUTE REGISTER

- C. The minute register hand indicates on the dial the number of minutes that have elapsed since the beginning of the registration of the sweep second hand. One complete revolution of the minute register hand indicates the passage of one hour.

TELEMETER

- D. The telemeter is used to denote the number of miles between two points. This is done by comparing the speed of light to the speed of sound.

METHOD OF USING TELEMETER

1. Start chronograph sweep second hand when you see lightning.
2. Stop the chronograph sweep second hand when you hear the thunder. The point on the telemeter scale where the sweep second hand stopped will indicate the distance in miles the lightning is away from you.

THE CHRONOGRAPH DIAL

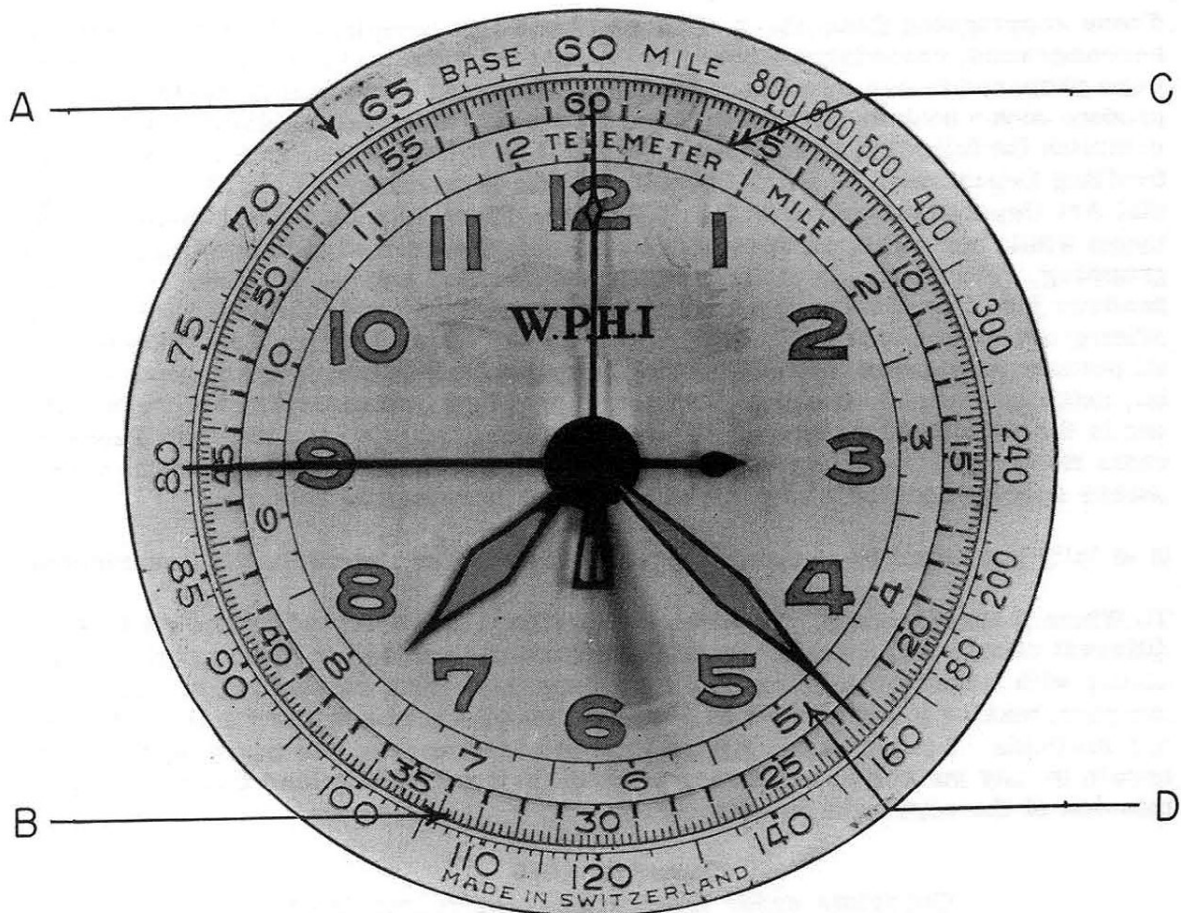

SETTING THE HANDS CORRECTLY ON A CHRONOGRAPH

After the chronograph is completely assembled and in working condition, replace the hour hand and the minute hand as you would on a regular watch. At this point, do not replace the minute register hand or the sweep second hand. Now push the button and bring the flyback lever in toward the center of the watch. When the flyback lever is held in toward the center of the watch, place the minute register hand at 60 on the minute register scale "C". Place the sweep second hand at 60 on split second scale "B". After these hands are replaced, start chronograph mechanism with sweep second hand turning. Let chronograph mechanism run for at least one minute. Now push the button to bring the flyback lever in toward the center of the watch again, and check to see that the minute register hand and the sweep second hand go back to their original position.