

WORLD'S ONLY  
FULLY ILLUSTRATED  
**CHRONOGRAPH WATCH COURSE**  
VOLUME 14

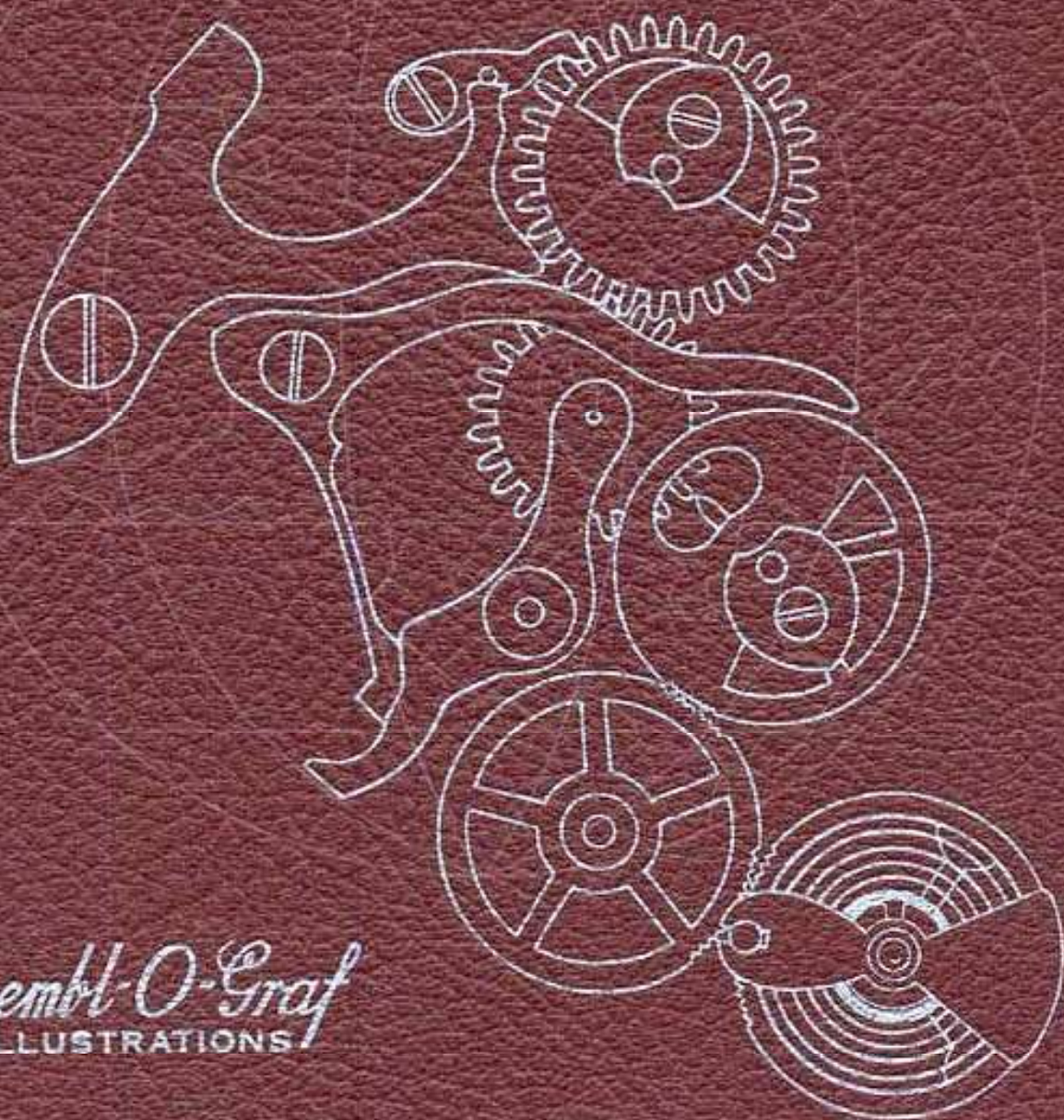

*Essembl-O-Graf*  
ILLUSTRATIONS

# IDENTIFICATION OF CHRONOGRAPH

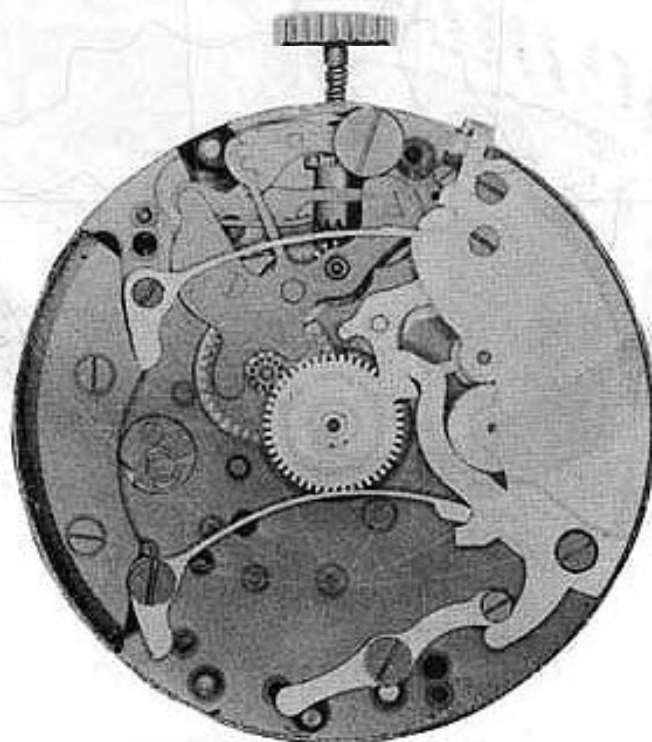

12L

LEMANIA



CAL. CH 27C12



# ESEMBL-O-GRAF

THE WORLD'S FIRST FULLY  
ILLUSTRATED TEXT BOOK  
ON  
CHRONOGRAPH REPAIRING  
AND ADJUSTING

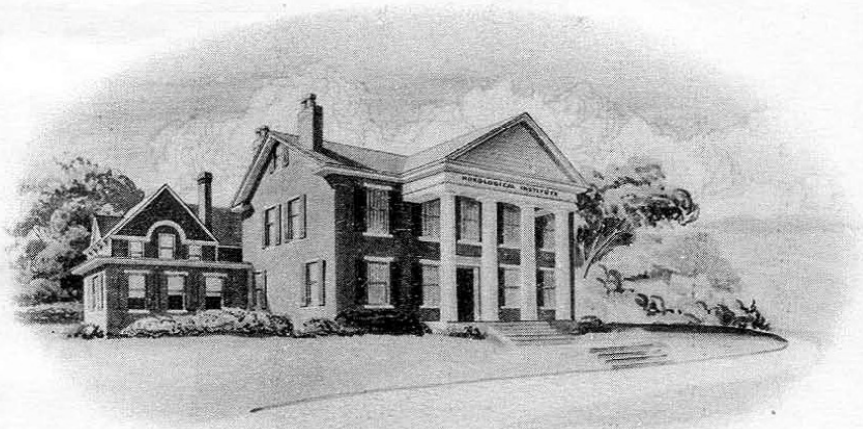

BY  
**William O. Smith, Sr.**  
PRESIDENT AND TECHNICAL DIRECTOR  
AND  
**William O. Smith, Jr.**  
CHIEF ENGINEER, RESEARCH LABORATORIES

WESTERN PENNSYLVANIA HOROLOGICAL INSTITUTE, INC.  
PITTSBURGH, PENNSYLVANIA

## INSTRUCTIONS

For use of book

### DISASSEMBLY OF THE CHRONOGRAPH MECHANISM:

1. Study the isometric drawing at top of page 1-A. The isometric drawing was made for the following purposes:
  - A. It helps to identify the part to be removed.
  - B. This drawing aids in pointing out certain locations on the part that are mentioned in the oiling procedure.
  - C. The text refers to certain points on the part. These points are shown in the isometric drawing. This should aid you in finding the exact location on the part that is described in the text.
  - D. It helps you to know the shape of the part in case a new part has to be made.
2. At the bottom of the page 1-A is a photograph of a chronograph. In this photograph is the same part painted in black. The part is in its exact location that this part occupies in the watch. Find this location in the watch.
3. Read the disassembly procedure and the hazards in disassembly on page 1 in this book.
4. Remove this part in the same procedure as described in the text.
5. A very important item in disassembling a chronograph is keeping the screws in order, much time will be lost in putting the chronograph together if screws are mixed up. This means you have to hunt for each screw, sometimes trying three or four screws before finding the correct one. It cannot be stressed too strongly that care should be taken so that screws are not mixed up. The system that we advise for beginners, is to replace each individual screw after each part is removed. This naturally eliminates the hazard of mixing up the screws and will save you much time in the end. Do this at least until you become so thoroughly familiar with the chronograph that you no longer feel it is necessary.
6. Continue to follow this procedure throughout the book and disassemble each part until the last part of the chronograph is removed.

### ASSEMBLY OF THE CHRONOGRAPH MECHANISM:

7. When you are ready to assemble the chronograph mechanism, study the isometric drawing on the last part in this book. This drawing should aid you in identifying the part to be assembled.
8. At the bottom of this page is a photograph of a chronograph. In this photograph is the same part painted in black. The part is in its exact location that this part occupies in the watch.
9. Read the assembly procedure and the hazards in assembling for the last part in this book. (Continued on next page)

## INSTRUCTIONS (Continued)

10. Replace the part in its exact location as shown in photograph, using the procedure as described in the text.

11. After you find the correct location for this part in the watch, read the oiling procedure for this part. The oiling procedure for this part is located underneath the isometric drawing. It is best to read the oiling procedure before you put each part in place as there are certain parts that must be oiled immediately as it may prove difficult to oil them later.

12. Replace the screw that holds this part in place. Of course, the screws should be kept in order as we advised above, but if the screws are not in order or the watch was received with screws mixed up, you will find a screw drawn for each part that requires a screw at the bottom of the text page.

13. After replacing this part, replace the next part, etc., until the last part is replaced, which will be part No. 1. Each part should be replaced using the same procedure as described in the text.

(Naturally, the assembly of the chronograph is exactly the reverse of the disassembly)

14. After disassembling and assembling the chronograph mechanism, start on page 1 and read the function of this part. After reading the function of this part, continue to read the function of each part throughout the book. Study each part, one at a time. This text should help you to understand more fully the purpose of each part in the chronograph mechanism.

15. Now put movement in its case with dial on, then replace hands.

16. Study the text on functional results in this book, and check the chronograph mechanism as described in this text.

### NOMENCLATURE OF PARTS FOR CHRONOGRAPH MECHANISM







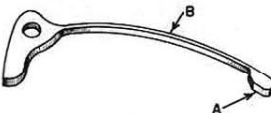
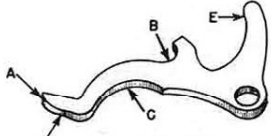

17. After you have become familiar with the chronograph mechanism, you can disassemble and assemble the chronograph by using the nomenclature of parts as a guide. This makes it possible for you to use a procedure without going through each page in the book.

#### 18. ADJUSTMENT OF ECCENTRIC STUDS:

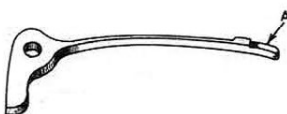
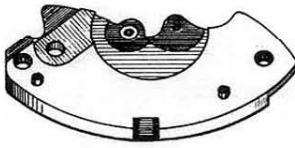
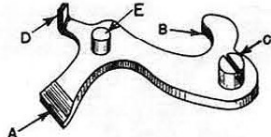
Read the text on adjustment of eccentric studs, this text should be read in reference to the eccentric stud picture. Now adjust each eccentric stud one at a time in the watch, as described in the text. Use the picture to show you the position of these studs.

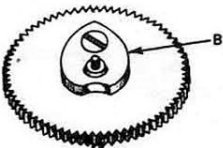
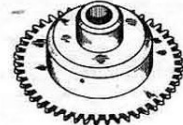

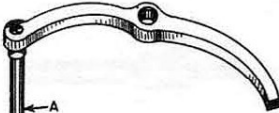

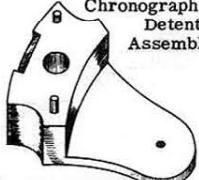
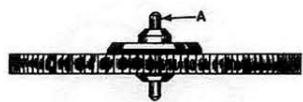
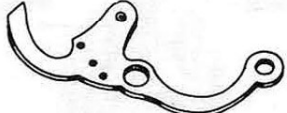
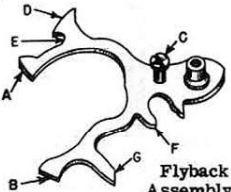
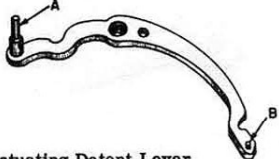
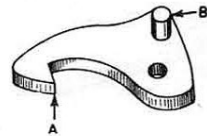
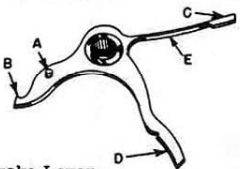
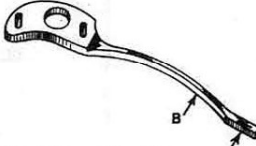

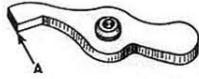

19. On each page in this book the part number and the page number are the same. This makes it convenient for the reader and eliminates any confusion.

# NOMENCLATURE OF PARTS FOR CHRONOGRAPH MECHANISM

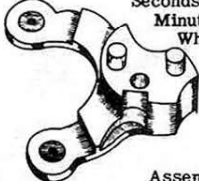
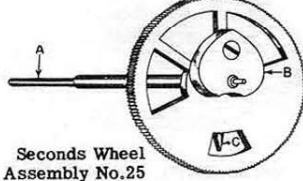
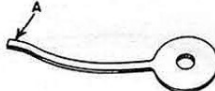
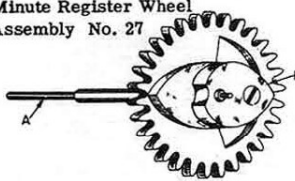
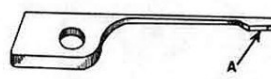
 <p>Hour Brake Lever Spring Assembly No. 1</p>	 <p>Hour Brake Lever Assembly No. 2</p>	 <p>Connecting Lever Assembly No. 3</p>
 <p>Hour Flyback Lever Spring Assembly No. 4</p>	 <p>Barrel Bridge Assembly No. 5</p>	 <p>Hour Flyback Lever Assembly No. 6</p>
 <p>Push Piece for Setting Back to Zero Assembly No. 7</p>	 <p>Hour Register Wheel Assembly No. 8</p>	 <p>Hour Wheel Assembly No. 9</p>
 <p>Wheel Over Fourth Wheel Assembly No. 10</p>	 <p>Actuating Lever for Hour Brake Assembly No. 11</p>	 <p>Chronograph Pivoted Detent and Actuating Detent Lever Spring Assembly No. 12</p>
 <p>Chronograph Pivoted Detent Bridge Assembly No. 13</p>	 <p>Intermediary Wheel Assembly No. 14</p>	 <p>Chronograph Pivoted Detent Assembly No. 15</p>
 <p>Flyback Lever Assembly No. 16</p>	 <p>Actuating Detent Lever Assembly No. 17</p>	 <p>Joint Hook Assembly No. 18</p>
 <p>Brake Lever Assembly No. 19</p>	 <p>Flyback Lever Spring Assembly No. 20</p>	

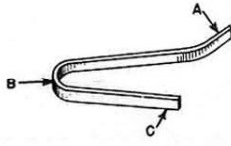
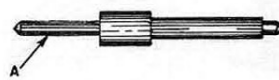
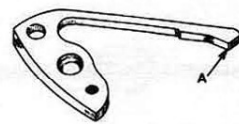
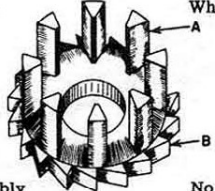
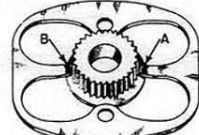
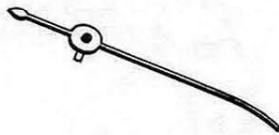
(Continued on Next Page)

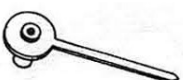
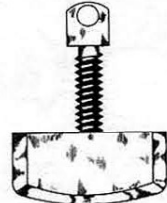
# NOMENCLATURE OF PARTS FOR CHRONOGRAPH MECHANISM

 <p>Minute Register Pawl Bridge Assembly No. 21</p>	 <p>Minute Register Pawl Assembly No. 22</p>	<p>Minute Register Pawl Spring Assembly No. 23</p> 
<p>Seconds Wheel and Minute Register Wheel Bridge</p>  <p>Assembly No. 24</p>	 <p>Seconds Wheel Assembly No. 25</p>	 <p>Seconds Wheel Tension Spring Assembly No. 26</p>
<p>Minute Register Wheel Assembly No. 27</p> 	 <p>Intermittent Lever Spring Assembly No. 28</p>	<p>Intermittent Lever and Wheel Assembly</p>  <p>Assembly No. 29</p>
 <p>Trip Pin Spring Assembly No. 30</p>	 <p>Trip Pin Assembly No. 31</p>	 <p>Castle Wheel Pawl Assembly No. 32</p>
<p>Castle Wheel</p>  <p>Assembly No. 33</p>	<p>Assembly No. 34</p>  <p>Driving Pinion Tension Spring and Driving Pinion.</p>	 <p>Sweep Second Hand</p>
 <p>Minute Register Hand</p>	 <p>Hour Register Hand</p>	
		



# ADJUSTING ECCENTRIC STUD DO NOT REMOVE THIS STUD DIAL SIDE

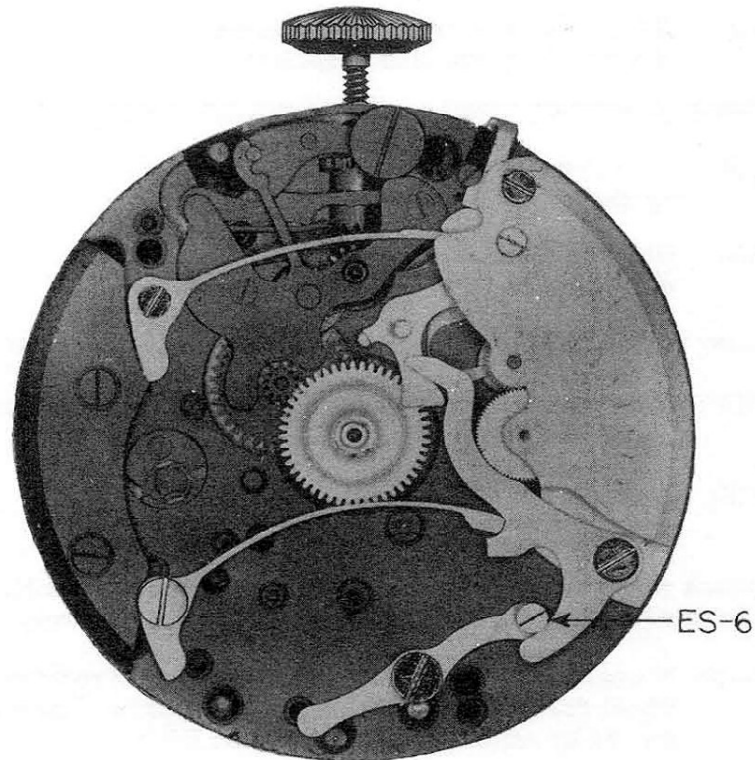

Listed below is the adjustment controlled by eccentric stud ES-6.

1. With chronograph engaged, check to see that hour brake lever is disengaged from hour register wheel.

CORRECTION: The disengaging of hour brake lever from hour register wheel may be adjusted by adjusting eccentric stud ES-6.

2. With chronograph mechanism engaged, check to see that hour brake lever prevents the hour flyback lever from contacting the heart on hour register wheel.

CORRECTION: If the hour brake lever permits the hour flyback lever to contact the heart on hour register wheel, this condition can be corrected by adjusting eccentric stud ES-6.

#### CAUTION

In disassembling or assembling chronograph it is a good policy not to turn eccentric studs. These eccentric studs are used to adjust one part to another and naturally in turning these studs you will lose the desired adjustment of the chronograph mechanism which will cause the chronograph to function incorrectly. Another reason for not turning these studs unless it is necessary is that they soon become loose and will not hold the desired adjustment.

## ADJUSTING ECCENTRIC AND ADJUSTING STUDS-THINGS TO CHECK

Listed below are a number of depthings and adjustments controlled by the eccentric studs and adjusting studs:

1. Check depthing of wheel over fourth wheel teeth and the intermediary wheel teeth.  
**CORRECTION:** If this depthing is incorrect, you can correct it by adjusting eccentric stud ES-1.  
**REFERENCE:** Wheel over fourth wheel is Assembly 10  
Intermediary wheel is Assembly 14.
2. Check depthings of seconds wheel teeth and intermediary wheel teeth.  
**CORRECTION:** If this depthing is incorrect, you can correct it by adjusting the adjusting stud AS-2.  
**REFERENCE:** Seconds wheel is Assembly 25.  
Intermediary wheel is Assembly 14.
3. Check depthing of intermittent wheel teeth and seconds wheel dart tooth.  
**CORRECTION:** If this depthing is incorrect, you can correct it by adjusting the adjusting stud AS-3.  
**REFERENCE:** Seconds wheel dart tooth is Assembly 25-C.  
Intermittent wheel is Assembly 29-A.
4. With the flyback lever holding the seconds wheel at a zero position, check to see that intermittent wheel is disengaged from seconds wheel dart tooth.  
**CORRECTION:** If intermittent wheel does not disengage from seconds wheel dart tooth at this time, this condition may be corrected by adjusting eccentric stud ES-4.  
**REFERENCE:** Flyback lever is Assembly 18.  
Seconds wheel is Assembly 25.
5. With the flyback lever holding the minute register wheel at a zero position, check to see that end "A" of the minute register pawl is centered between two teeth on the minute register wheel.  
**CORRECTION:** The minute register pawl can be adjusted so the end "A" of this pawl is centered between two teeth on the minute register wheel by loosening fillister head screw FS-4 and adjusting eccentric stud ES-5. After pawl is properly adjusted, tighten fillister head screw FS-4.  
**REFERENCE:** Flyback lever is Assembly 16.  
Minute register wheel is Assembly 27.  
Minute register pawl is Assembly 22.

# ADJUSTING ECCENTRIC STUDS

DO NOT REMOVE THESE STUDS  
TRAIN SIDE

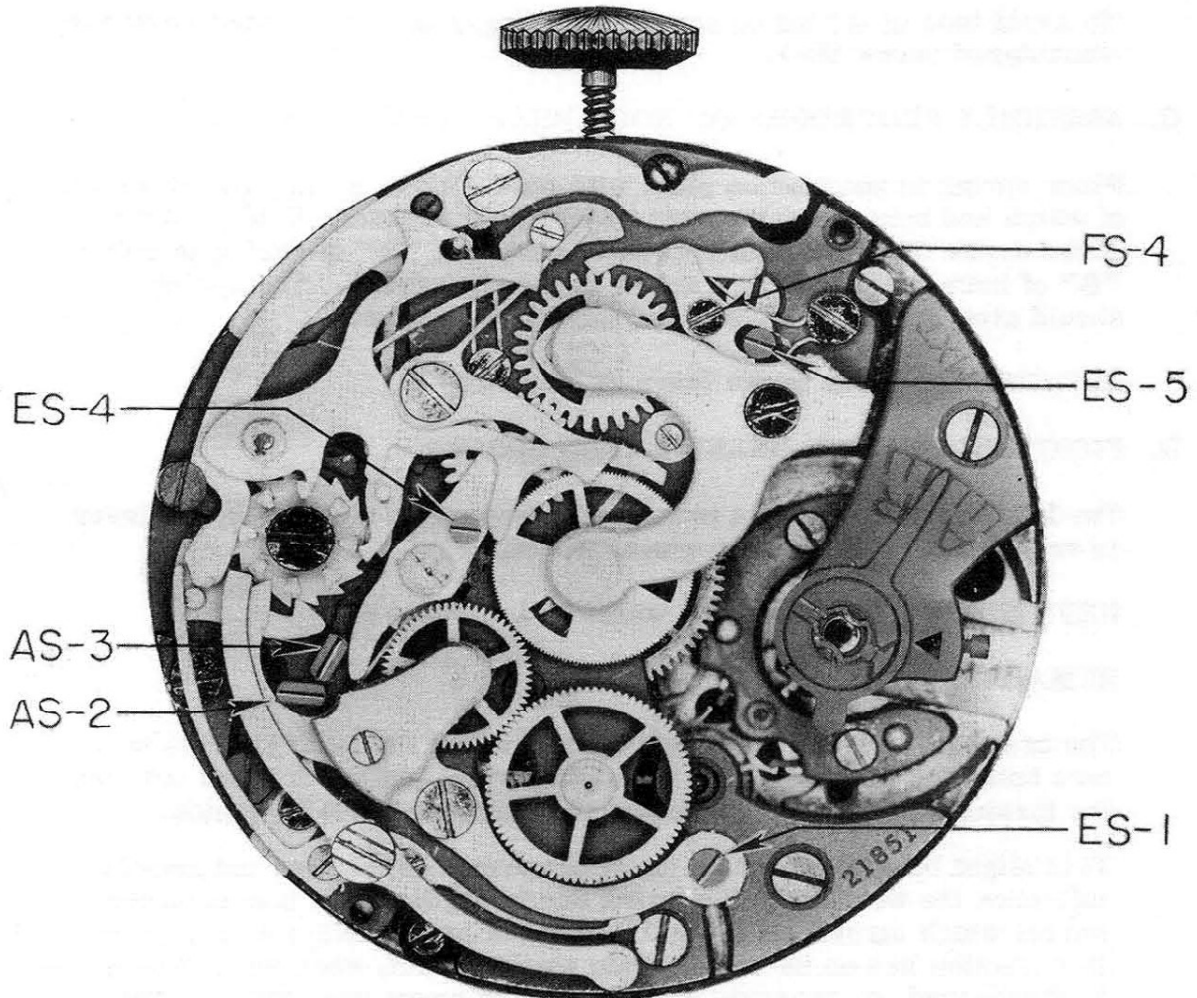

## CAUTION

In disassembling or assembling chronograph, it is a good policy not to turn eccentric studs. These eccentric studs are used to adjust one part to another, and, naturally, in turning these studs you will lose the desired adjustment of the chronograph mechanism, which will cause the chronograph to function incorrectly. Another reason for not turning these studs, unless it is necessary, is that they soon become loose and will not hold the desired adjustment.

**A. DISASSEMBLY PROCEDURE OF HOUR BRAKE LEVER SPRING:**

This spring is held in place by shouldered screw SS-1. Hold finger on spring when removing screw. After screw is removed, spring may be lifted from movement.

(The shape of screw for this part is shown at bottom of page.)

**B. HAZARDS IN DISASSEMBLY OF HOUR BRAKE LEVER SPRING:**

To avoid loss of spring or screw, hold finger on spring while removing shouldered screw SS-1.

**C. ASSEMBLY PROCEDURE OF HOUR BRAKE LEVER SPRING:**

Place spring in position on plate with part "B" of spring toward center of watch and hole in spring over proper hole in plate. Replace shouldered screw SS-1 and with tweezers place end "A" of spring in notch "B" of hour brake lever as shown in the photograph. The spring should pivot freely under head of shouldered screw.

**REFERENCE:** Hour brake lever is Assembly 2.

**D. FUNCTION OF HOUR BRAKE LEVER SPRING:**

The function of this spring is to hold a tension on the hour brake lever to engage it with the hour register wheel.

**REFERENCE:** Hour register wheel is Assembly 8.

**REMARKS:**

The brake lever holds the hour register wheel stationary. This in turn holds the driving pinion stationary which causes friction between the turning mainspring barrel and the stationary driving pinion.

This slight braking effect on the mainspring barrel does not greatly influence the working of the watch due to the fact that it acts on the barrel which turns with a great amount of power. What small effect this friction has on the watch train would in fact, when the chronograph is disengaged, compensate slightly for the heavy resistance to the watch train when chronograph is engaged.

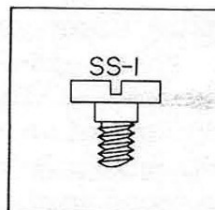

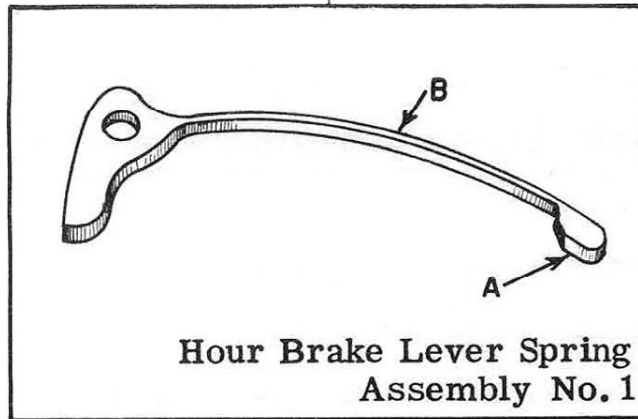

### OILING

End "A" of hour brake lever spring should be slightly moistened with oil at the point of contact with hour brake lever.

### DIAL SIDE

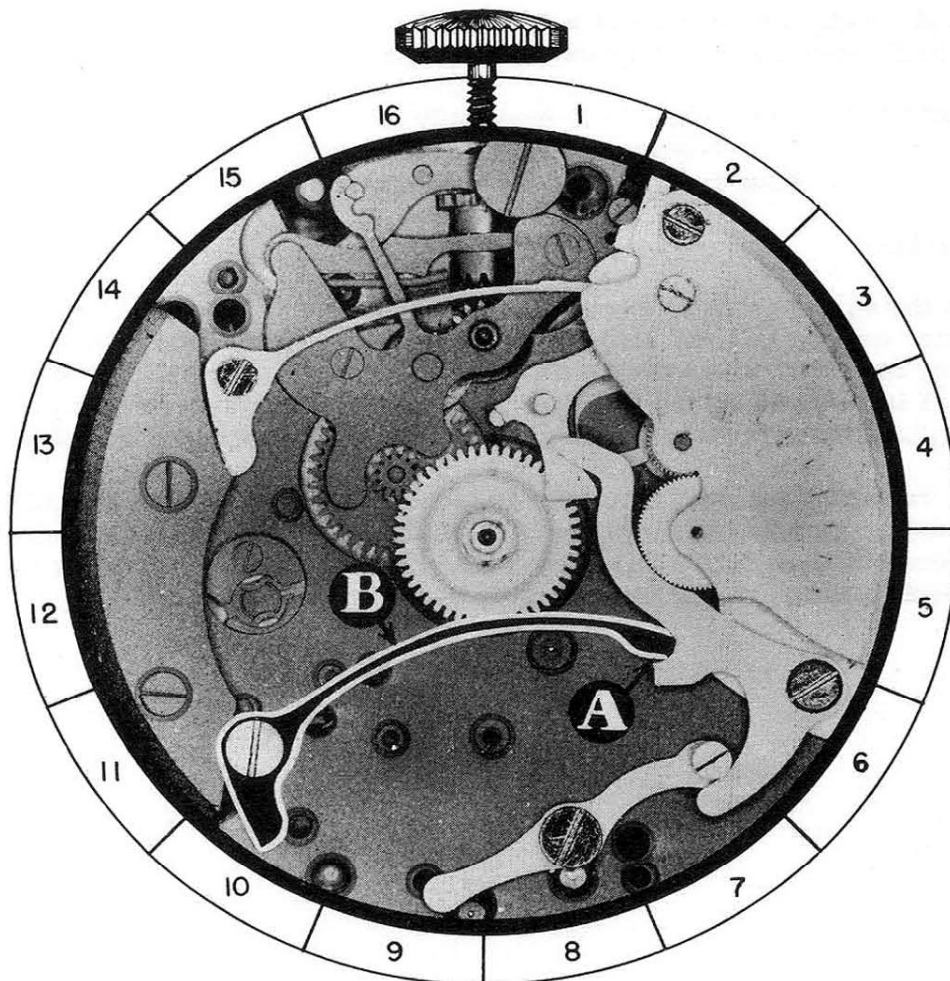

1-A

**A. DISASSEMBLY PROCEDURE OF HOUR BRAKE LEVER:**

This part is held in place by a shouldered screw SS-2 and pivots under the head of this screw. Remove screw, and lever may be lifted from barrel bridge and free of movement.

(The shape of screw for this part is shown at the bottom of the page.)

**B. ASSEMBLY PROCEDURE OF HOUR BRAKE LEVER:**

Place hole in lever over proper hole in barrel bridge, as shown in the photograph. Now replace shouldered screw SS-2 that holds this lever in place. This lever should pivot freely under head of screw. The screw for this part helps to hold the barrel bridge down on plate.

**C. FUNCTION OF HOUR BRAKE LEVER:**

The functions of the hour brake lever are:

1. It holds the hour register wheel, in a stationary position, when permitted to do so by the chronograph mechanism.
2. It prevents the hour flyback lever from engaging with hour register wheel, when the chronograph mechanism is engaged.

REFERENCE: Barrel bridge is Assembly 5.  
Hour register wheel is Assembly 8.  
Hour flyback lever is Assembly 6.

**REMARKS:**

When the chronograph is engaged and the hour brake lever is free of the hour register wheel, the hour brake lever prevents the hour flyback lever from returning the wheel to a zero position. This is due to the end "D" of the hour flyback lever striking the end "A" of the hour brake lever, which prevents the flyback lever from contacting the heart on the hour register wheel.

After replacing the hour brake lever, the hour register wheel should be checked for proper endshake and side shake. The barrel arbor should be checked to see that it has proper endshake and the flyback lever should be checked to see that it pivots freely in the bridge without binding.

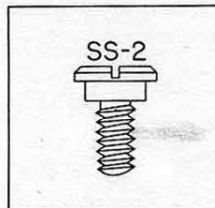

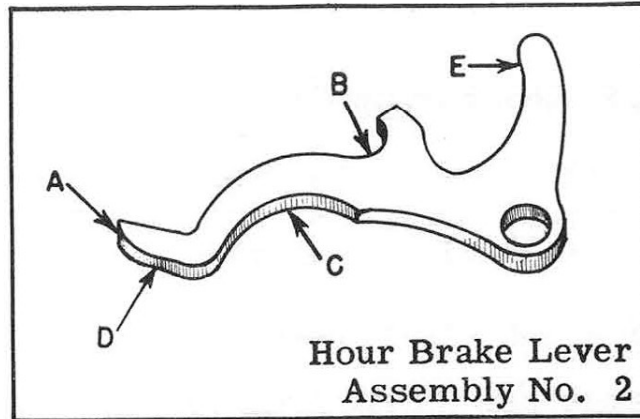

Hour Brake Lever  
Assembly No. 2

### OILING

The following points on hour brake lever should be slightly moistened with oil:

1. The shoulder of screw that brake lever pivots on.
2. End "E" of brake lever that contacts eccentric stud on connecting lever.
3. End "D" of brake lever that contacts hour flyback lever.

### DIAL SIDE

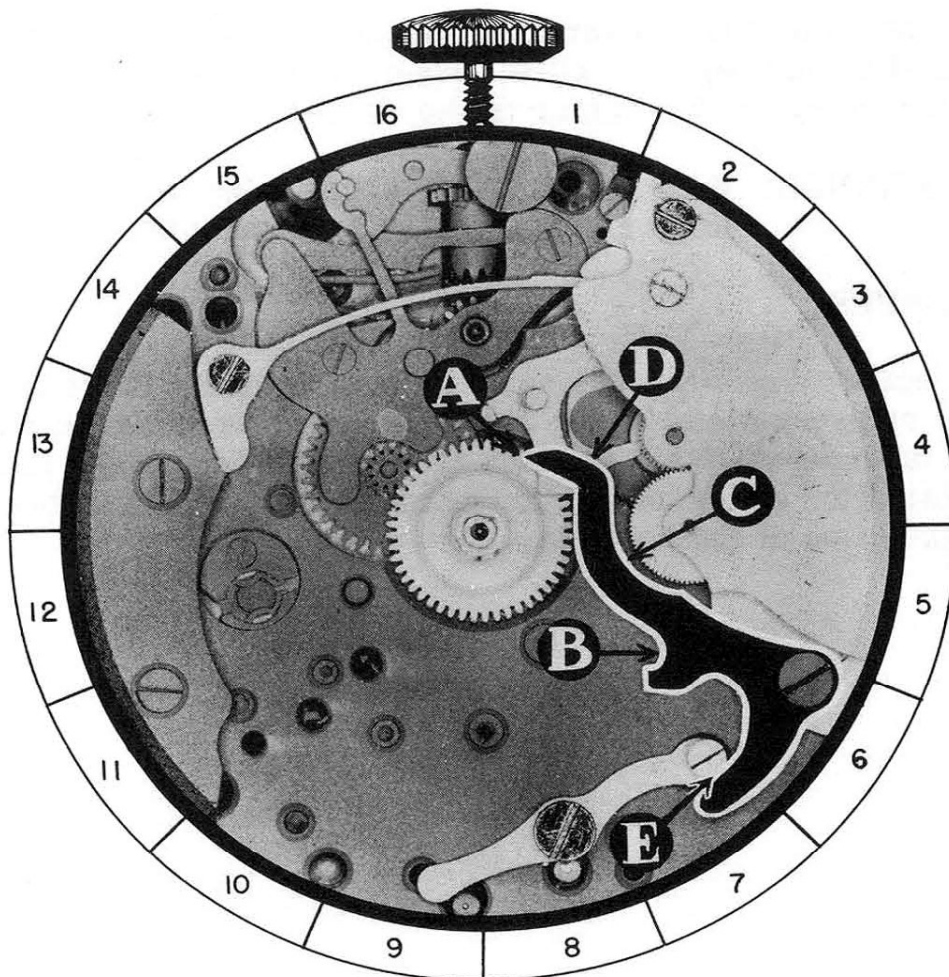

2-A

**A. DISASSEMBLY PROCEDURE OF CONNECTING LEVER:**

This lever is held in place by a shouldered screw SS-3 and pivots under head of this screw. After screw has been removed, lever may be lifted from plate.

(The shape of screw for this part is shown at bottom of page.)

**B. ASSEMBLY PROCEDURE OF CONNECTING LEVER:**

Place hole in lever over proper hole in plate, with the eccentric stud up. The end "A" of this lever should be on the inside of pin "A", as shown in photograph. Replace shouldered screw SS-3 to hold this lever in position. The connecting lever should pivot freely under head of shouldered screw.

**C. FUNCTION OF CONNECTING LEVER:**

The function of this lever is to disengage the hour brake lever from the hour register wheel, when the end "A" of this lever is forced toward the center of the watch.

**REFERENCE:** Hour brake lever is Assembly 2.  
Hour register wheel is Assembly 8.

**REMARKS:**

The connecting lever disengages the hour brake lever from the hour register wheel at the same time the chronograph mechanism is engaged. This permits the hour register hand to begin registration of the hours, the instant the second hand begins registration of the seconds.

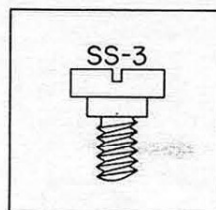



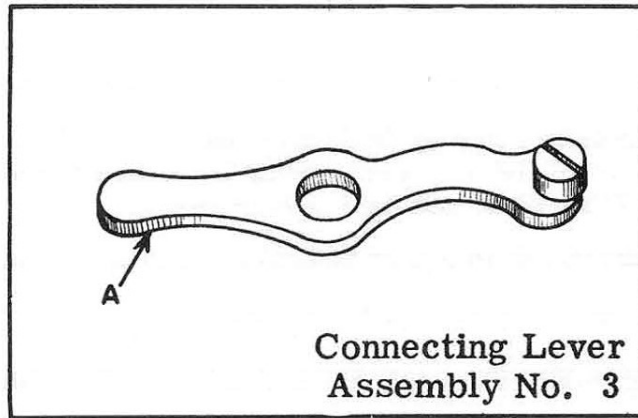

### OILING

- The following points on connecting lever should be slightly moistened with oil:
1. Shoulder of screw on which the connecting lever pivots.
  2. End "A" at point of contact with pin "A" on actuating lever for hour brake.

### DIAL SIDE

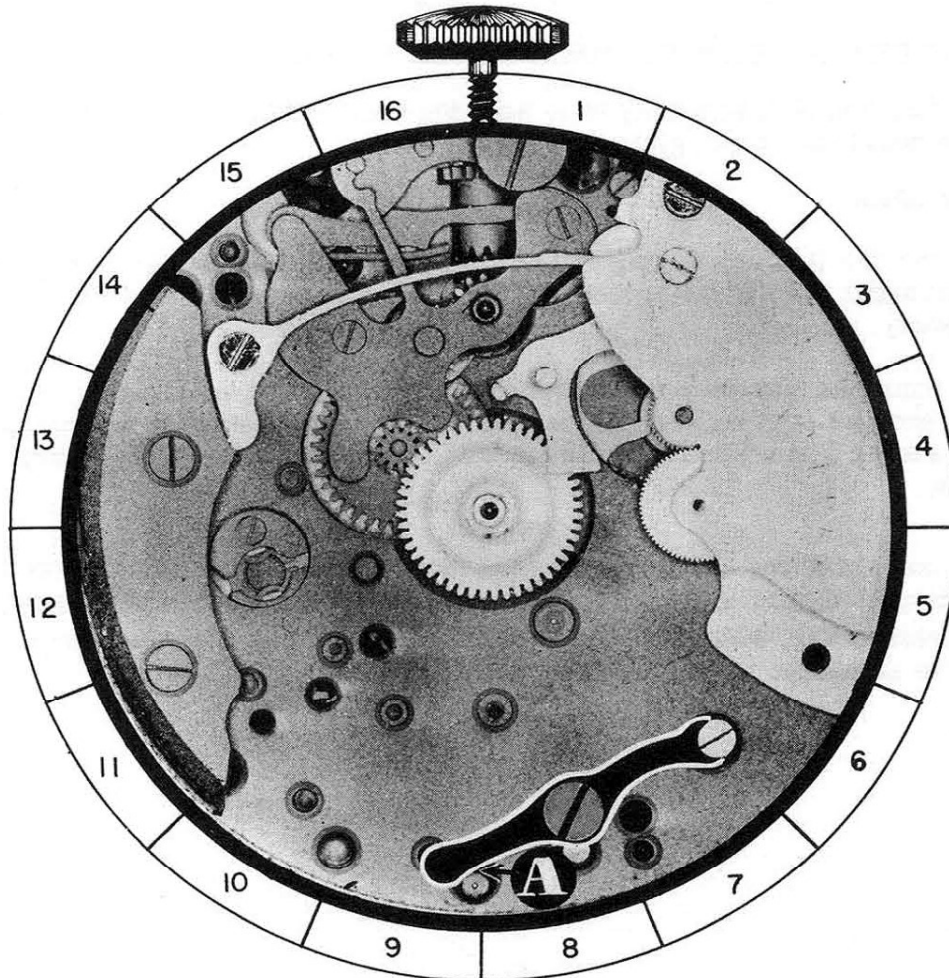

3-A

**A. DISASSEMBLY PROCEDURE OF HOUR FLYBACK LEVER SPRING:**

This spring is held in place by fillister head screw FS-1. Remove screw, and slide end "A" of flyback lever spring from underneath barrel bridge. Now lift spring from plate and free of movement.

(The shape of screw for this part is shown at bottom of page.)

REFERENCE: Barrel bridge is Assembly 5.

**B. HAZARDS IN DISASSEMBLY OF HOUR FLYBACK LEVER SPRING:**

Hold finger over spring when removing screw so that it will not be lost.

**C. ASSEMBLY PROCEDURE OF HOUR FLYBACK LEVER SPRING:**

Slide end "A" of spring under barrel bridge where it will contact inside of part "B" on hour flyback lever. Tension of this spring must disengage hour flyback lever from hour register wheel. Place hole in spring over proper hole in plate. Hold spring in position with finger, and replace fillister head screw FS-1.

REFERENCE: Hour flyback lever is Assembly 6.  
Hour register wheel is Assembly 8.

**D. FUNCTION OF HOUR FLYBACK LEVER SPRING:**

The function of this spring is to hold the hour flyback lever disengaged from heart on hour register wheel.

**REMARKS:**

The tension that any spring in the chronograph holds on a part should be no stronger than is necessary for the spring to perform its function properly.

For example, any excess tension that a spring holds on a part to engage it with another part makes it unnecessarily hard to disengage the two parts. Too strong a tension of the spring will also cause excessive wearing of parts.

The tension of the spring to the part is properly adjusted by the factory, but in case a spring must be made or a spring has been replaced by another watchmaker, when adjusting the tension of this spring the above remarks should be taken into consideration.

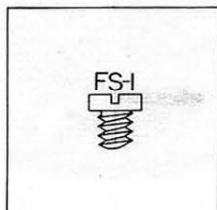

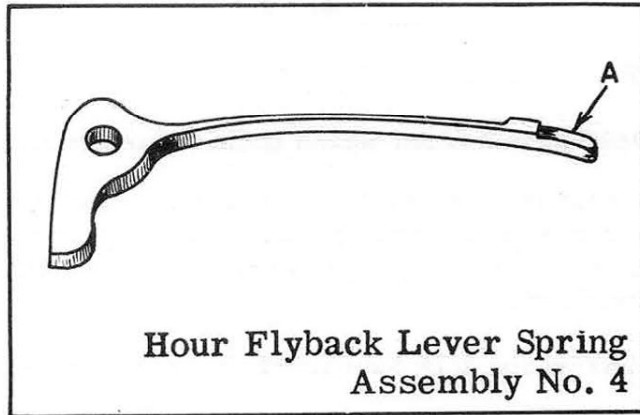

### OILING

End "A" of hour flyback lever spring should be slightly moistened with oil at point of contact with hour flyback lever.

### DIAL SIDE

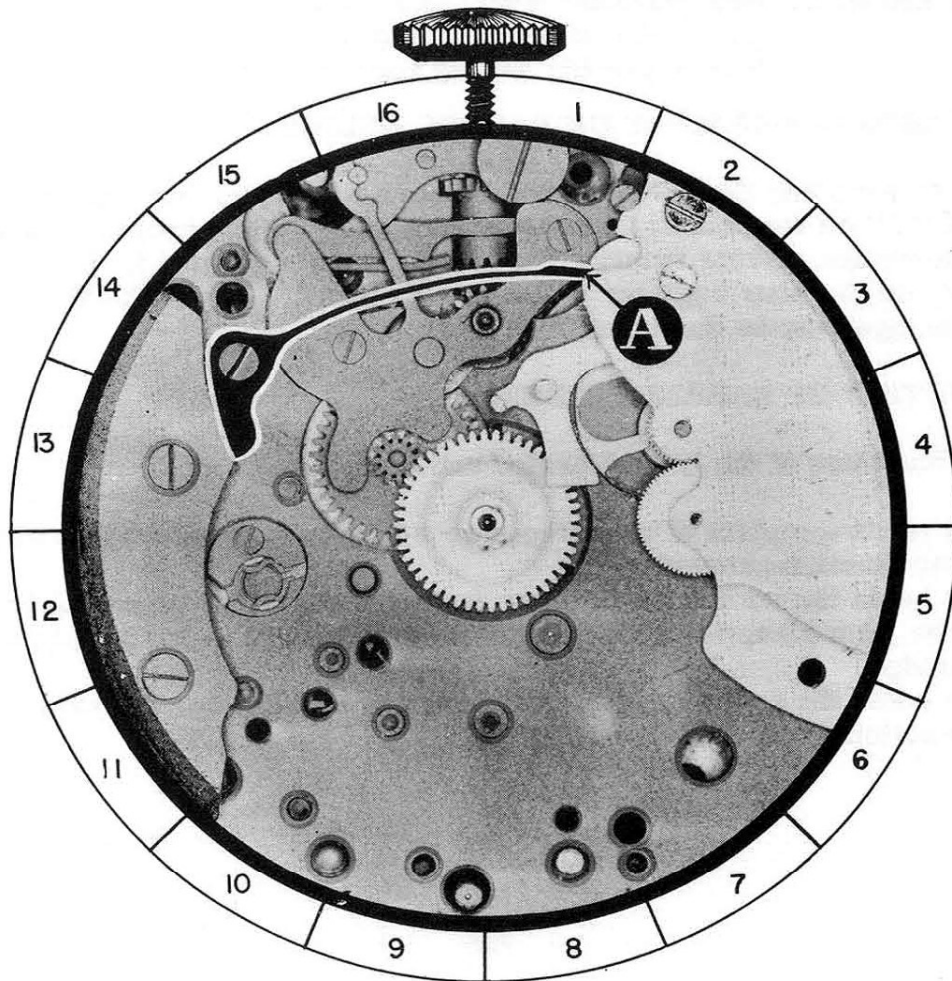

4-A

**A. DISASSEMBLY PROCEDURE OF BARREL BRIDGE:**

**Caution:** Release power from watch train before removing this bridge.

This bridge is held in place by fillister head screw, FS-2 and steady pins. Remove screw and loosen bridge from plate with a thin blade screw-driver. When steady pins are free in plate, bridge may be lifted from movement.

(The shape of screw for this part is shown at bottom of page.)

**B. ASSEMBLY PROCEDURE OF BARREL BRIDGE:**

Place bridge on plate, as shown in photograph, with steady pins over proper holes in plate. Check to see that barrel arbor pivot, hour register wheel pivot, and the screw-head on hour flyback lever are entering the proper holes in bridge. Check to see that push piece for setting back to zero is in proper place. Now press the bridge down to proper place, and replace fillister head screw FS-2. Position of this screw is shown in the photograph.

**REFERENCE:** Hour register wheel is Assembly 8.  
Hour flyback lever is Assembly 6.  
Push piece for setting back to zero is Assembly 7.

**C. HAZARDS IN ASSEMBLY OF BARREL BRIDGE:**

Before pressing the bridge down, be sure the pivots and screw head "C" on the hour flyback lever are entering the proper holes in the bridge. Avoid twisting the bridge when replacing it, or the pivots on the hour register wheel and the pivot holes in the plate and bridge may be damaged.

**D. FUNCTION OF BARREL BRIDGE:**

The functions of the barrel bridge are as follows:

1. It holds top pivot of hour register wheel in position, so this wheel can function properly.
2. It holds the hour flyback lever in position to function properly.
3. The push piece for setting back to zero is held in position by this bridge.
4. It holds the top pivot of barrel arbor in position for the barrel to function properly.

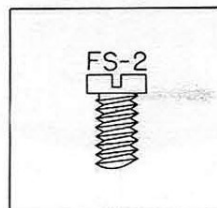

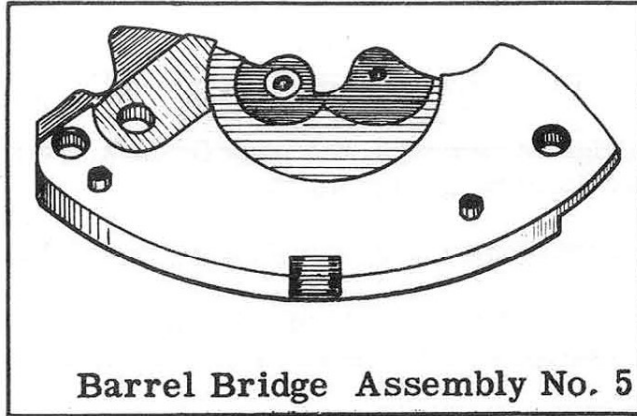

Barrel Bridge Assembly No. 5

The following points on barrel bridge should be oiled:

1. The top pivot of hour register wheel should be oiled as you would normally oil a train pivot.
2. The top pivot of barrel arbor should be oiled as you would normally oil a barrel arbor pivot in a watch.

DIAL SIDE

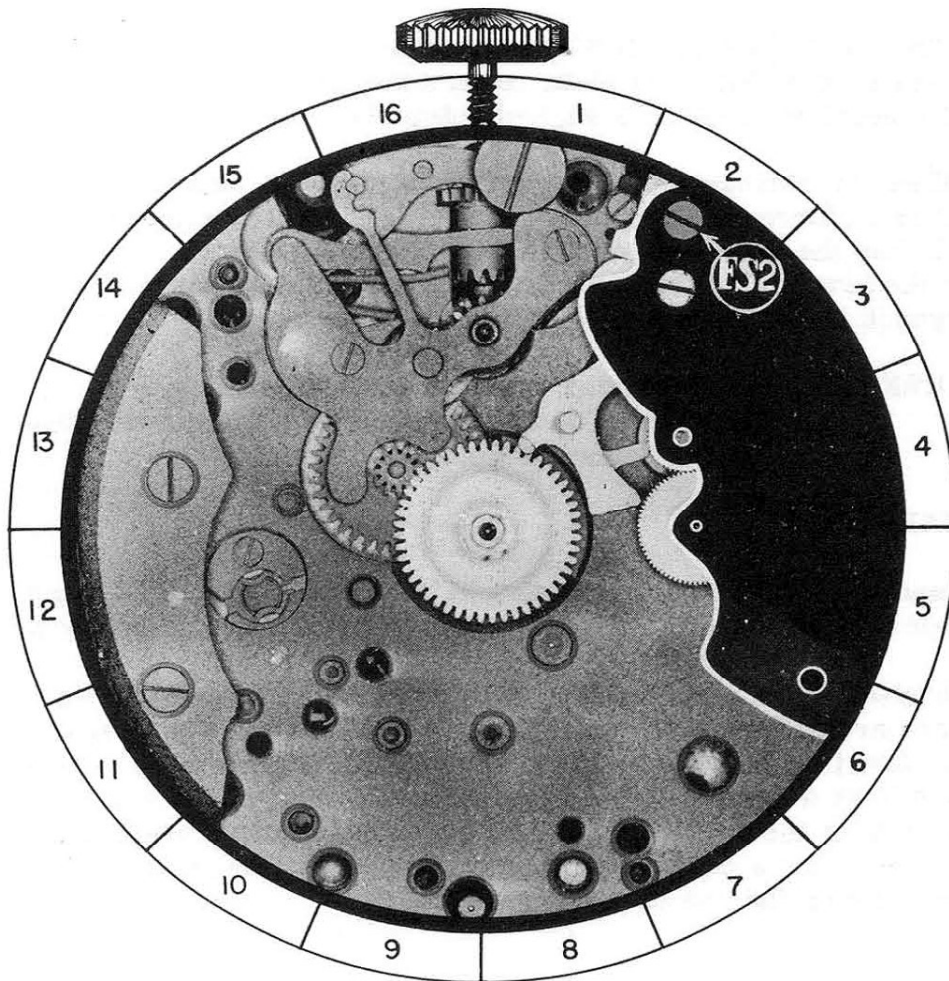

5-A

**A. DISASSEMBLY PROCEDURE OF HOUR FLYBACK LEVER:**

After barrel bridge is removed, the hour flyback lever is free on plate and can be lifted from movement.

**B. ASSEMBLY PROCEDURE OF HOUR FLYBACK LEVER:**

Place lever on plate with screw head "C" up, as shown in photograph, with the threaded end of screw down in hole in plate.

**C. FUNCTION OF HOUR FLYBACK LEVER:**

The functions of this lever are:

1. It disengages the hour brake lever from hour register wheel when hour flyback lever is forced to contact the heart on this wheel.
2. The end "A" of hour flyback lever contacts the heart on the hour register wheel, forcing it to a zero position, when the push piece for setting back to zero is pushed.
3. When push piece for setting back to zero is released, the flyback lever forces this push piece toward outside of watch and holds it in this position, until it is pushed manually.
4. When the chronograph mechanism is engaged, and the hour flyback lever is forced toward the heart on the hour register wheel, the end "D" on the hour flyback lever will contact point "A" on the hour brake lever. This will prevent any further movement of the hour flyback lever toward the heart on the hour register wheel.

**REFERENCE:** Hour register wheel heart is Assembly 8-B.  
Push piece for setting back to zero is Assembly 7.  
Barrel bridge is Assembly 5.

**REMARKS:**

The end "A" of flyback lever should be highly polished, as any pits of rust or roughness at this location may cause it not to function properly.

When repairing a chronograph, it is most important that the screwdrivers are properly sharpened and the correct size of screw-driver blade used for each screw slot. Most of the screws used in the chronograph have a highly polished head and are very easily marred by a slight slip of the screwdriver. To have these screw heads marred, while repairing a chronograph, will indicate carelessness either in sharpening or the use of the screwdrivers.

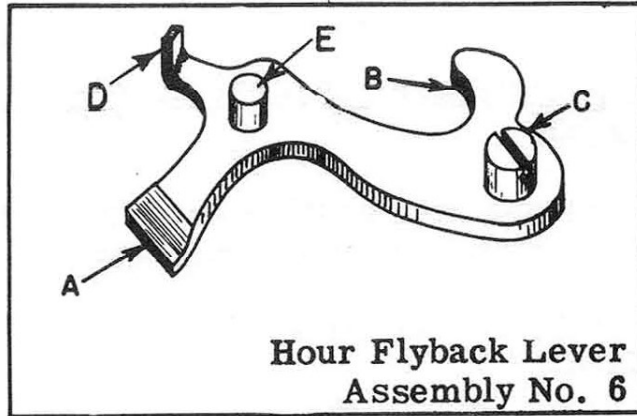

### OILING

The surface of screw-head "C", that contacts the barrel bridge, should be slightly moistened with oil.

### DIAL SIDE

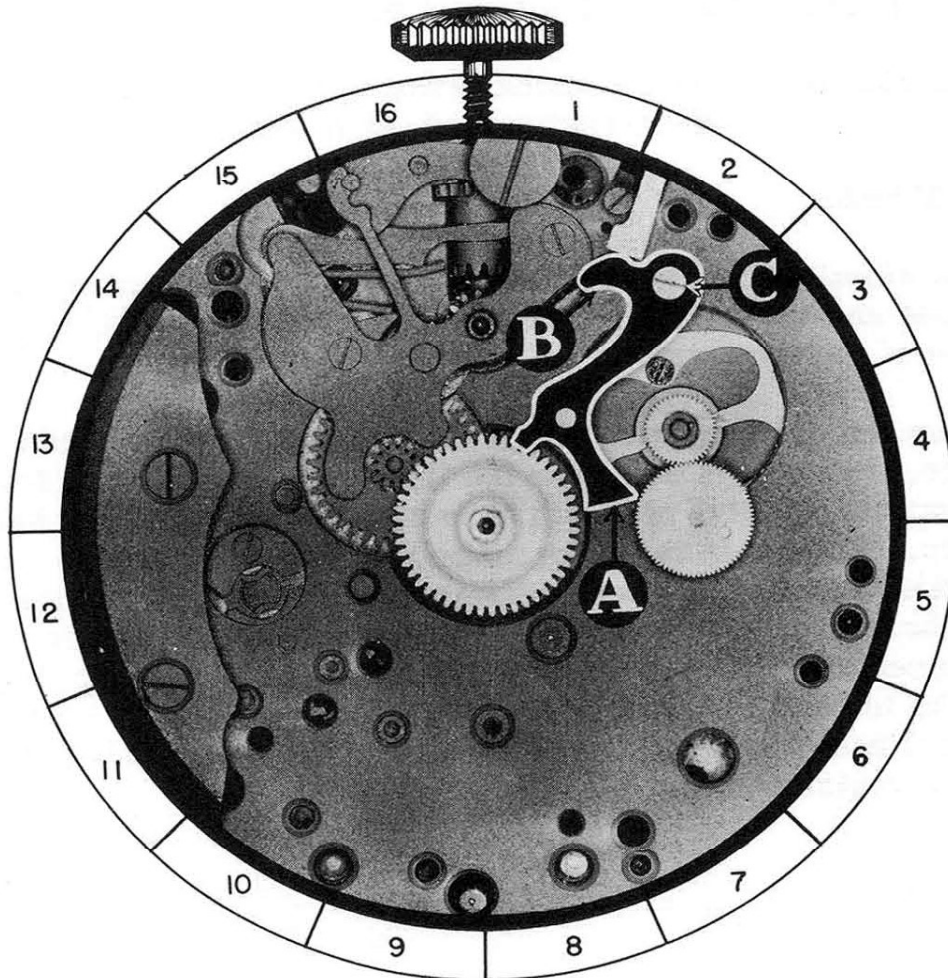

6-A

**A. DISASSEMBLY PROCEDURE OF PUSH PIECE FOR SETTING BACK TO ZERO:**

This push piece was held in place by barrel bridge. Lift push piece from plate and free of movement.

**B. ASSEMBLY PROCEDURE OF PUSH PIECE FOR SETTING BACK TO ZERO:**

Place push piece on plate with end "A" toward center of watch, as shown in photograph. This part is held in place by the barrel bridge and screw head "D", as shown in photograph.

**C. FUNCTION OF PUSH PIECE FOR SETTING BACK TO ZERO:**

This push piece forces the hour flyback lever to contact the heart on hour register wheel, forcing the wheel and hand to a zero position when push piece is pushed manually.

**REFERENCE:** Hour flyback lever is Assembly 6.  
Hour register wheel is Assembly 8.

**REMARKS:**

The simultaneous setting back to zero of the chronograph hands and the hour register hand is greatly simplified in this type of chronograph.

When the chronograph button is pushed to set the hands to zero, the trip pin releases the flyback lever which is forced in toward the center of watch to return the chronograph hands to zero. While this is taking place the manual pressure on the button returns the hour register hand to a zero position. Due to these two flyback levers performing their functions from independent sources of power, there is no close adjustment to make to be sure that the pressure of flyback lever on seconds wheel heart is equal to the pressure of hour flyback lever on hour register wheel heart.



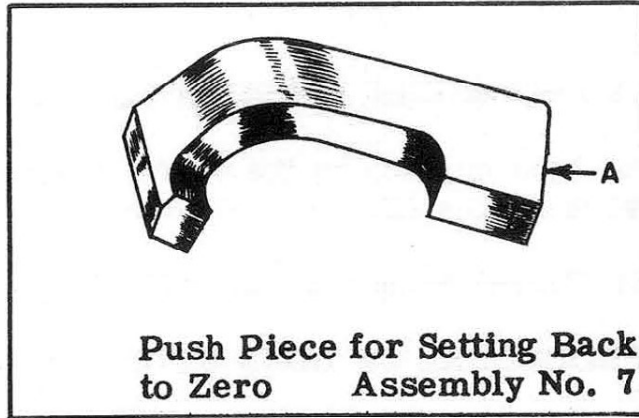

### OILING

End "A" of push piece should be slightly moistened with oil  
at point of contact with hour flyback lever.

### DIAL SIDE

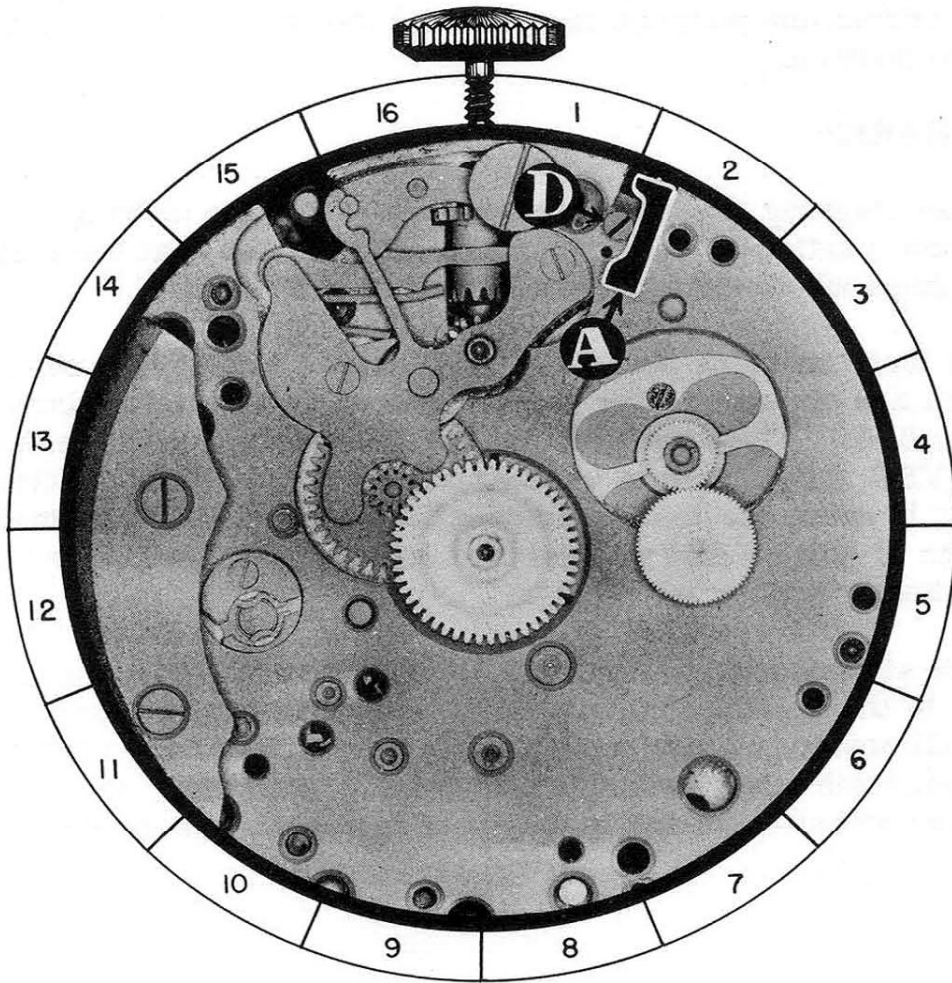

7-A

**A. DISASSEMBLY PROCEDURE OF HOUR REGISTER WHEEL:**

This wheel was held in place by the barrel bridge. The hour register wheel is simply lifted out of place.

REFERENCE: Barrel bridge is Assembly 5.

**B. ASSEMBLY PROCEDURE OF HOUR REGISTER WHEEL:**

Place wheel in position with the heart "B" down and the pivot in proper hole in plate.

**C. FUNCTION OF HOUR REGISTER WHEEL:**

The function of this wheel is to register the hours that have elapsed since the beginning of the registration. This is done by means of a hand being attached to the staff of the hour register wheel. The heart "B", in conjunction with the hour flyback lever, serves the purpose of returning the wheel and the hand to a zero position.

**REMARKS:**

When cleaning the hour register wheel and the driving pinion, particular care should be taken to see that the teeth on these wheels are clean and free of grit or dirt.

The teeth on these parts are VEE shaped teeth (VEE shaped teeth are shown on hour register wheel in isometric drawing on page 8-A.) When the VEE shape teeth of one wheel mesh into the VEE shape teeth of another wheel, there is very little clearance between the teeth, and because of this, even the smallest piece of grit or dirt wedged into one of these teeth may stop the hour register mechanism.

This stoppage is particularly apt to occur in this movement due to the driving pinion turning from friction on barrel. A small amount of dirt between pinion teeth and hour register wheel teeth may overcome this friction, stopping the hour register wheel resulting in an error in register of hours.

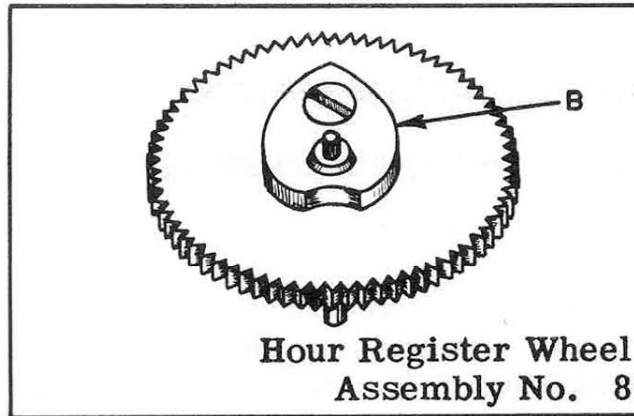

### OILING

The bottom pivot of hour register wheel should be oiled before replacing pivot in place in plate. The top pivot should be oiled after barrel bridge is replaced.

### DIAL SIDE

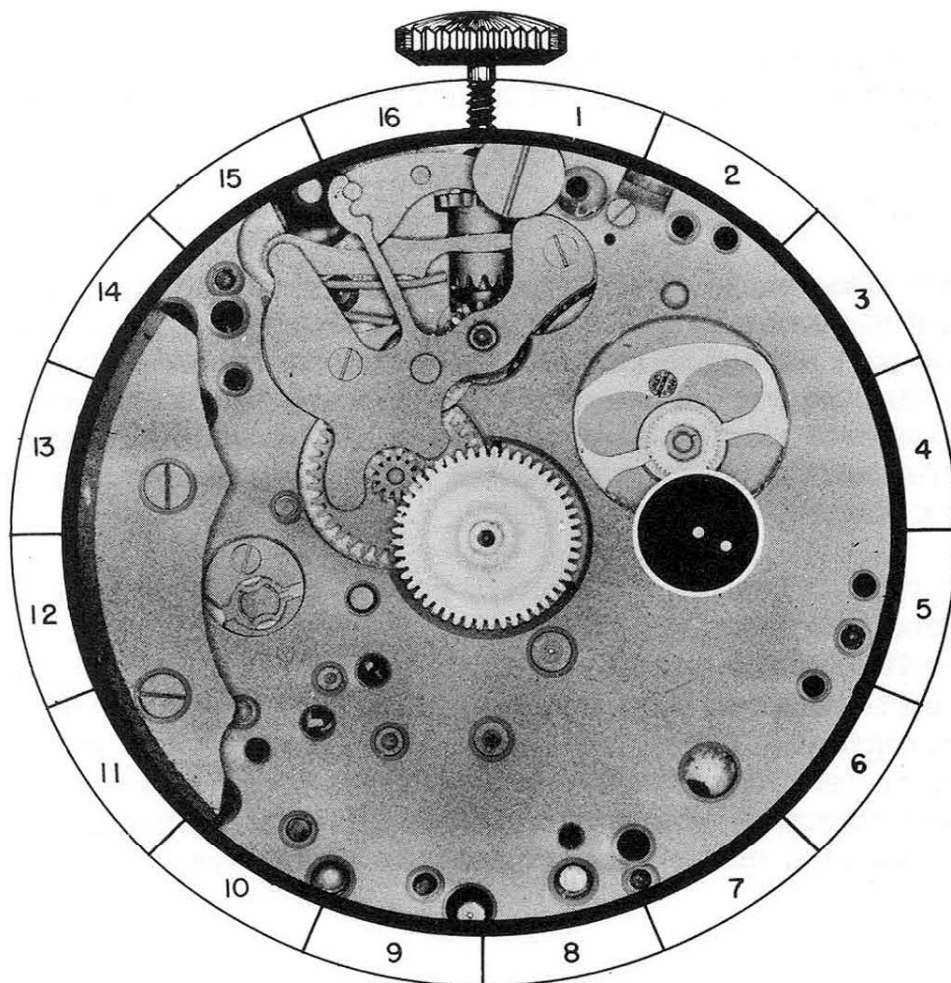

8-A

**A. DISASSEMBLY PROCEDURE OF HOUR WHEEL:**

This wheel is removed by simply lifting it out of place.

**NOTICE**

This completes the disassembly of the dial side of the chronograph at this time. Now turn the chronograph over, and disassemble the train side of the chronograph, by following the instructions in this book.

**B. ASSEMBLY PROCEDURE OF HOUR WHEEL:**

This wheel is placed over cannon pinion and pushed down in place, so that the teeth of hour wheel engage with the leaves of the minute wheel pinion.

**C. FUNCTION OF HOUR WHEEL:**

The function of the hour wheel is to register passage of hours on the dial of the watch. This is done by a hand being attached to this wheel.

**REMARKS:**

When disassembling the chronograph, each part should be carefully examined as it is removed from the movement. Each part should be checked against the isometric drawings to see that the part is the correct shape and is not broken. Each part should also be checked for any pits of rust, roughness, or burrs, and for worn parts, which may cause the part not to work properly.

The replacement of a defective part in the chronograph may necessitate complete disassembly of the chronograph. It will save time in the end to make this examination and the necessary corrections to each defective part while disassembling the chronograph. Through this close examination, you will soon become familiar with the various parts of the mechanism. This will enable you to quickly recognize a defective part, and repair it before replacing in the chronograph.

Hour Wheel Assembly No. 9

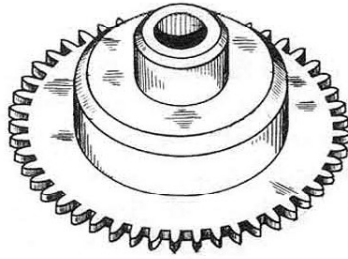

OILING

The hour wheel should not be oiled.

DIAL SIDE

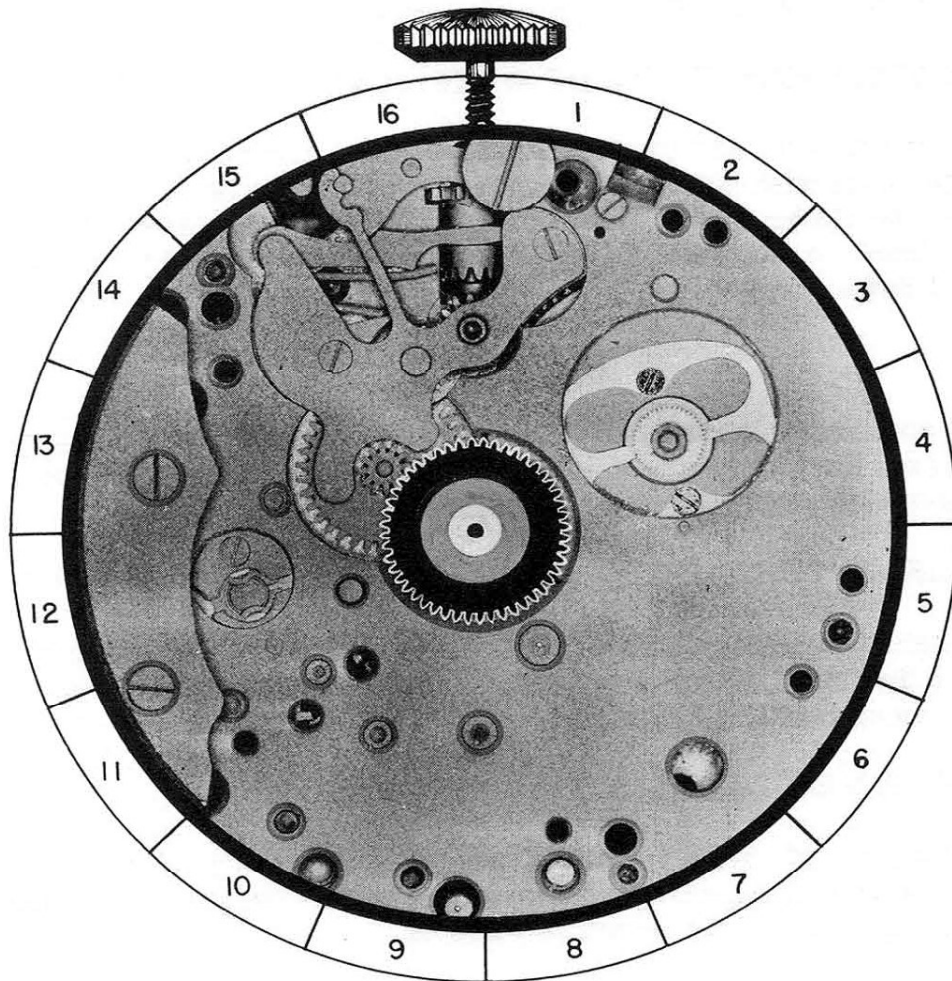

9-A

**A. DISASSEMBLY PROCEDURE OF WHEEL OVER FOURTH WHEEL:**

Wheel over fourth wheel fits friction tight on the long pivot of fourth wheel pinion. This wheel should be removed with a sweep wheel remover, but can be removed with two small thin edge screwdrivers. The screwdrivers are placed opposite each other under hub "A" of wheel. One screwdriver is turned clockwise, while the other screwdriver is turned counter-clockwise. This will loosen the wheel from the pivot, permitting it to be lifted out of place.

**B. HAZARDS IN DISASSEMBLY OF WHEEL OVER FOURTH WHEEL:**

The wheel over fourth wheel fits over the very thin pivot of the fourth wheel pinion, which is, as you know, very delicate and easily bent or broken. The main reason why we select this part to be removed first is to lessen the hazards of bending or breaking the long pivot on the fourth wheel pinion, while removing the other parts of the chronograph mechanism. If the sweep wheel remover is held perfectly upright in removing this wheel, hazard of bending the fourth wheel pivot will be eliminated.

**C. ASSEMBLY PROCEDURE OF WHEEL OVER FOURTH WHEEL:**

This wheel fits over the fourth wheel pivot and should be placed on the pivot with hub "A" of wheel down. The wheel over fourth wheel should be staked down, until it is level with the intermediary wheel. A hollow-flat-faced punch should be used to stake the wheel down.

**NOTICE**

This completes the assembly of the train side of the chronograph. Now turn the chronograph over and assemble the dial side of the chronograph, by following the instructions in the text.

**D. HAZARDS IN ASSEMBLY OF WHEEL OVER FOURTH WHEEL:**

Use care in staking down this wheel so that you do not bend or break the fourth wheel pivot. If movement is held level, the hazards of replacing this wheel will be eliminated.

**E. FUNCTION OF WHEEL OVER FOURTH WHEEL:**

The function of this wheel is to transmit the power from the train of the watch to the chronograph mechanism. This wheel continues to turn as long as the watch is running.

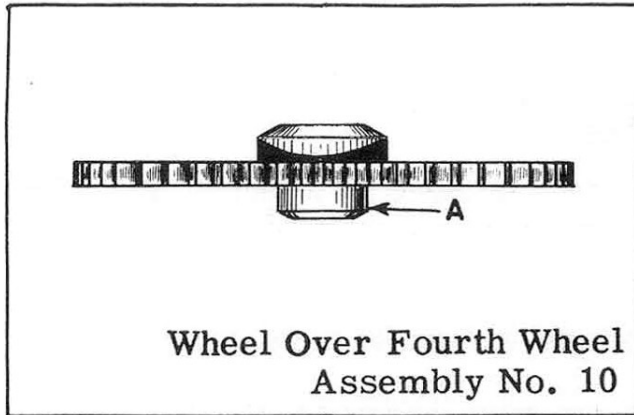

### OILING

The wheel over fourth wheel should not be oiled.

### TRAIN SIDE



10-A

**A. DISASSEMBLY PROCEDURE OF ACTUATING LEVER FOR HOUR BRAKE:**

This lever is held in place by a left threaded shouldered screw SS-4 and pivots under head of this screw. When the screw is removed, lever may be lifted from movement.

(The shape of screw for this part is shown at bottom of page.)

**B. HAZARDS IN DISASSEMBLY OF ACTUATING LEVER FOR HOUR BRAKE:**

The left threaded shouldered screw that holds this part in place can be easily identified by the parallel grooves on either side of the screw slot. When removing this screw, if it is turned counter-clockwise, instead of clockwise, it will become tighter and may strip the threads in the plate or on the screw.

**C. ASSEMBLY PROCEDURE OF ACTUATING LEVER FOR HOUR BRAKE:**

Place actuating lever for hour brake over proper hole in actuating detent and chronograph pivoted detent spring, as shown in photograph. The pin "A" should be down in hole in plate. Replace left threaded shouldered screw SS-4. Check to see that lever pivots freely under head of screw.

**D. FUNCTION OF ACTUATING LEVER FOR HOUR BRAKE:**

The function of this lever is to disengage the hour brake lever from hour register wheel, when the chronograph mechanism is engaged.

**REFERENCE:** Hour brake lever is Assembly 2.  
Hour register wheel is Assembly 8.  
Chronograph pivoted detent and actuating detent lever spring is Assembly 12.

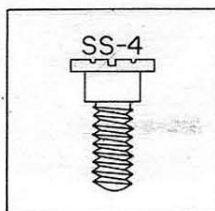



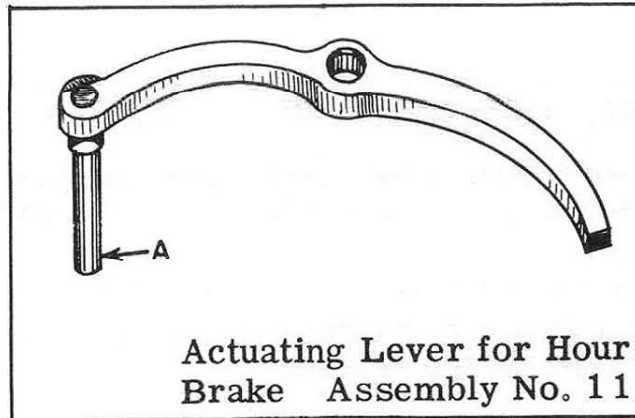

### OILING

The shoulder of screw, on which actuating lever for hour brake pivots, should be slightly moistened with oil.

### TRAIN SIDE



**A. DISASSEMBLY PROCEDURE OF CHRONOGRAPH PIVOTED DETENT AND ACTUATING DETENT LEVER SPRING:**

This spring is held in place by two beveled countersink screws BS-1 and BS-2. Remove screws, and spring will be free on plate and may be lifted from movement.

(The shape of screws for this part is shown at bottom of page.)

**B. HAZARDS IN DISASSEMBLY OF CHRONOGRAPH PIVOTED DETENT AND ACTUATING DETENT LEVER SPRING:**

Hold finger over spring while removing screws, so that spring or screws will not be lost.

**C. ASSEMBLY PROCEDURE OF CHRONOGRAPH PIVOTED DETENT AND ACTUATING DETENT LEVER SPRING:**

Place spring over proper holes in plate, as shown in photograph. End "B" of spring should contact the outside of pin "B" on joint hook forcing it toward center of watch. End "A" of spring should contact chronograph pivoted detent forcing it toward center of watch. Hold spring in place with finger and replace beveled countersink screws BS-1 and BS-2.

**REFERENCE:** Chronograph pivoted detent is Assembly 15.  
Joint hook is Assembly 18.

**D. FUNCTION OF CHRONOGRAPH PIVOTED DETENT AND ACTUATING DETENT LEVER SPRING:**

The functions of this spring are as follows:

1. End "A" holds a tension on the chronograph pivoted detent, forcing it toward the center of the watch.
2. End "B" forces the joint hook and actuating detent lever in toward the center of the watch.
3. End "B" forces the end "A" of joint hook to contact the ratchet teeth on the castle wheel.
4. End "B" holds joint hook flush on the plate.

**REFERENCE:** Chronograph pivoted detent is Assembly 15.  
Joint hook is Assembly 18.  
Castle wheel ratchet teeth is Assembly 33-B.  
Actuating detent lever is Assembly 17.

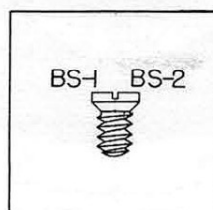

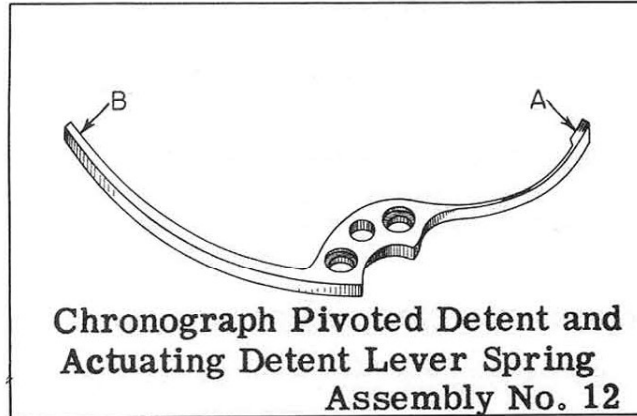

### OILING

The following points of this spring should be slightly moistened with oil:

1. End "A" at point of contact with the chronograph pivoted detent.
2. End "B" at point of contact with pin "B" on joint hook.

### TRAIN SIDE



12-A

**A. DISASSEMBLY PROCEDURE OF CHRONOGRAPH PIVOTED DETENT BRIDGE:**

This bridge is held in place by beveled countersink screw BS-3 and steady pins. Remove screw, and loosen bridge from detent with a thin blade screwdriver. When steady pins are free of detent, bridge may be lifted from detent.

(The shape of screw for this part is shown at bottom of page.)

**E. HAZARDS IN DISASSEMBLY OF CHRONOGRAPH PIVOTED DETENT BRIDGE:**

When using a screwdriver to loosen bridge from detent, keep bridge level, as any twisting may damage the pivots on intermediary wheel, or burr the bushings in bridge or pivoted detent.

**REFERENCE:** Intermediary wheel is Assembly 14.  
Chronograph pivoted detent is Assembly 15.

**C. ASSEMBLY PROCEDURE OF CHRONOGRAPH PIVOTED DETENT BRIDGE:**

Place pivot hole in bridge over pivot of intermediary wheel. Place steady pins over proper holes in chronograph pivoted detent, and push down in place with back of tweezers. Replace beveled countersink screw BS-3, that holds this bridge in position.

**D. HAZARDS IN ASSEMBLY OF CHRONOGRAPH PIVOTED DETENT BRIDGE:**

Bridge must be kept level when pressing down to proper place with back of tweezers, as any twisting may damage pivots on intermediary wheel or pivot hole in bridge or pivoted detent. Before replacing bridge, check to see that bridge and chronograph pivoted detent are free from burrs, that would prevent bridge from setting properly on chronograph pivoted detent.

**E. FUNCTION OF CHRONOGRAPH PIVOTED DETENT BRIDGE:**

The function of this bridge is to hold the intermediary wheel in place, so it can function properly.

**REMARKS:**

At this point, the intermediary wheel should be checked to see that it will not rise above the level of the seconds wheel. The endshake of the intermediary wheel, plus the vertical movement or endshake of chronograph pivoted detent under screw head, should not permit the intermediary wheel to drop below the level of the seconds wheel, when the chronograph is placed in a dial up position.

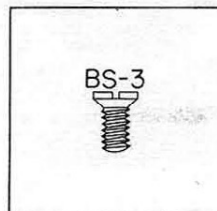

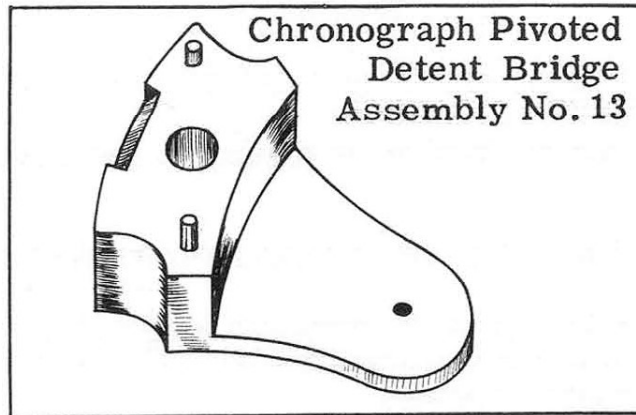

### OILING

The pivot in bushing, in chronograph pivoted detent bridge, should be oiled as you would properly oil a train pivot in a watch.

### TRAIN SIDE



13-A

**A. DISASSEMBLY PROCEDURE OF INTERMEDIARY WHEEL:**

This wheel is simply lifted out of bushing in chronograph pivoted detent.

**B. ASSEMBLY PROCEDURE OF INTERMEDIARY WHEEL:**

When replacing intermediary wheel, the long end "A" of staff should be up. Place the bottom pivot of staff in hole in bushing of chronograph pivoted detent.

REFERENCE: Chronograph pivoted detent is Assembly 15.

**C. HAZARDS IN ASSEMBLY OF INTERMEDIARY WHEEL:**

Examine carefully the pivot hole in bushing in chronograph pivoted detent before replacing intermediary wheel. Any imperfection here will affect the timekeeping of the watch and hinder the proper operation of the chronograph.

**D. FUNCTION OF INTERMEDIARY WHEEL:**

The function of this wheel is to transfer the power from the wheel over fourth wheel to the seconds wheel, when these wheels are engaged. The intermediary wheel continues to turn as long as the watch is running.

REFERENCE: Wheel over fourth wheel is Assembly 10.  
Seconds wheel is Assembly 25.

**REMARKS:**

When the chronograph mechanism is disengaged, the intermediary wheel should be separated from the seconds wheel only the distance necessary to be sure that these wheels will not touch at any time. Any excess separation of these two wheels will increase the "Movement of Translation" when the intermittent wheel moves to engage with the seconds wheel.

For example: If the wheel over fourth wheel is held stationary and the intermediary wheel is moved to engage with seconds wheel, the intermediary wheel must turn on its axis. This turning of the intermediary wheel on its axis is known as the "Movement of Translation". When the "Movement of Translation" is excessive, it may cause the seconds hand to jump forward at the instant chronograph is engaged.

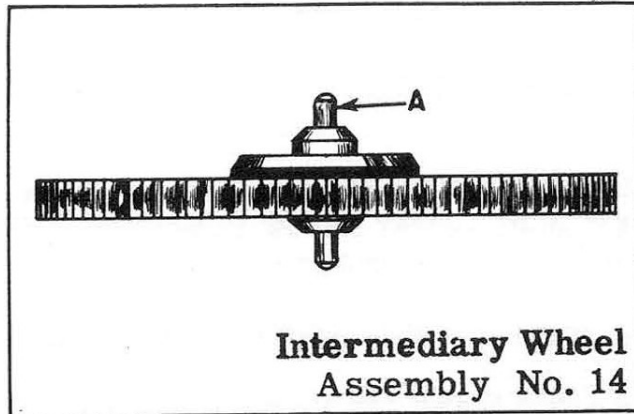

### OILING

The bottom pivot of intermediary wheel should be oiled before replacing pivot in place in chronograph pivoted detent. The top pivot should be oiled after bridge for this wheel is placed on detent.

### TRAIN SIDE



14-A

**A. DISASSEMBLY PROCEDURE OF CHRONOGRAPH PIVOTED DETENT:**

This detent is held in place by shouldered screw SS-5 and pivots on an eccentric stud. After screw is removed, the detent may be lifted from eccentric stud and free of plate.

(The shape of screw for this part is shown at bottom of page.)

**B. ASSEMBLY PROCEDURE OF CHRONOGRAPH PIVOTED DETENT:**

Place detent on plate, with hole in end of detent over eccentric stud "B", as shown in photograph. Replace shouldered screw SS-5. The detent must move freely under the head of this screw.

**C. HAZARDS IN ASSEMBLY OF CHRONOGRAPH PIVOTED DETENT:**

After replacing detent, check to see that it has enough freedom to move freely under head of screw and yet does not have excess freedom. Detent must also be checked to see that it pivots freely on eccentric stud.

**D. REMARKS:**

This chronograph is a semi-instantaneous type of chronograph. It is possible to note immediately if the chronograph is a semi-instantaneous type by observation of the progress of the minute register hand.

The minute register hand on semi-instantaneous type of chronograph will remain stationary until about the 58th second of registration. Between the 58th and 60th second of registration, the hand will move forward very slowly. At the 60th second of registration, the minute register hand will move forward very quickly to complete the registration of one minute on the dial. Of course, the minute register hand progresses in the same manner for each consecutive minute of registration.

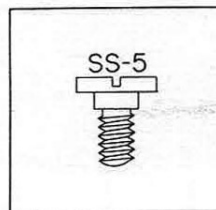



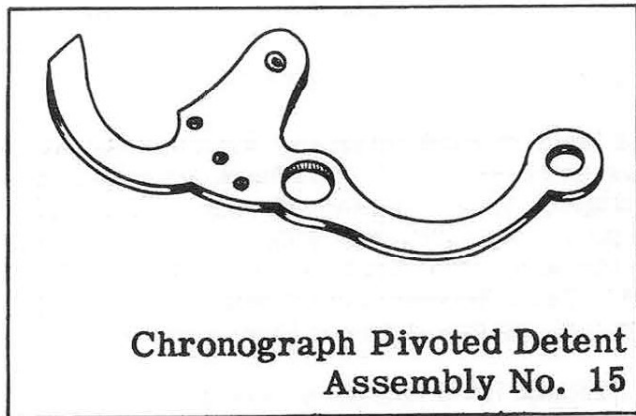

**OILING**

The eccentric stud, that the chronograph pivoted detent pivots on, should be slightly moistened with oil

**TRAIN SIDE**

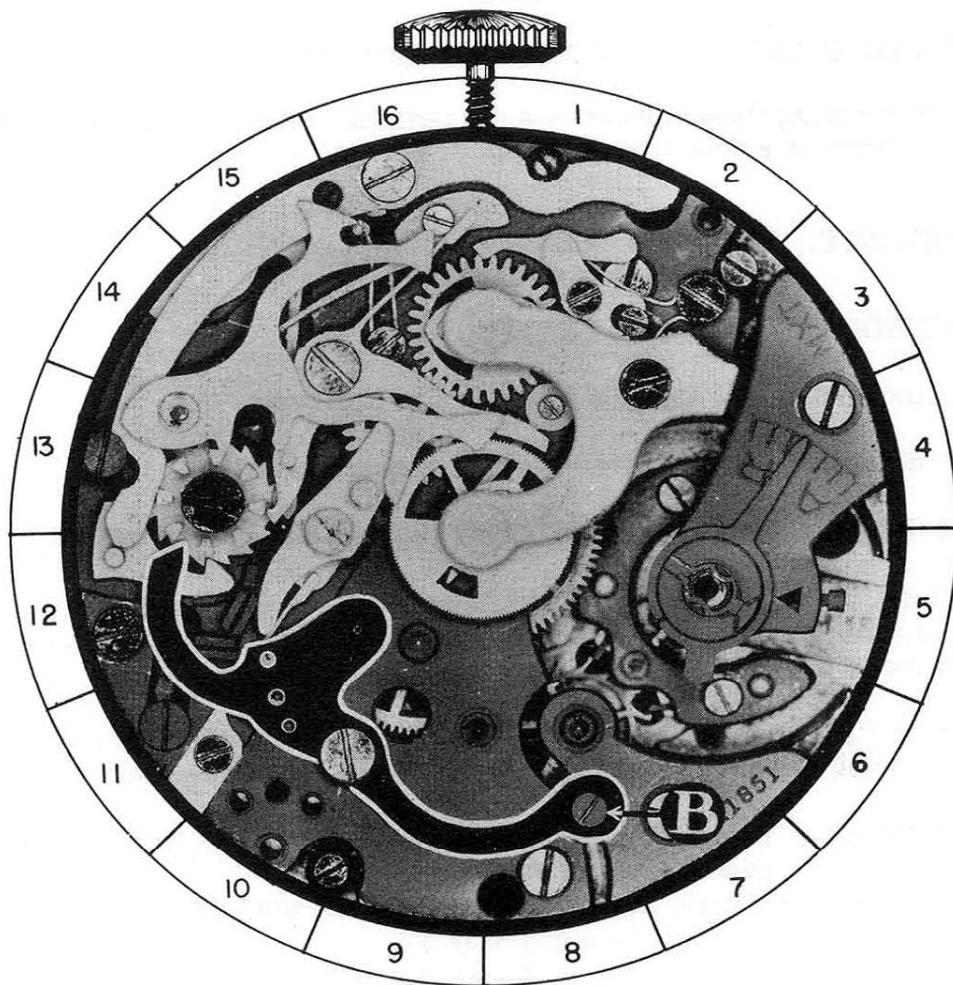

**15-A**

**A. DISASSEMBLY PROCEDURE OF FLYBACK LEVER:**

Turn the flyback lever toward outside of watch as far as possible. Now place a screwdriver at point "B" on flyback lever spring, and force end "A" of spring slightly toward outside of watch, and at the same time applying a downward pressure. This will unhook end "A" of spring from between flyback lever and screw head "C". When end "A" of flyback lever spring is unhooked from between screw head "C" and flyback lever, lift flyback lever straight up to remove it from post on plate.

**REFERENCE:** Flyback lever spring is Assembly 20.

**B. ASSEMBLY PROCEDURE OF FLYBACK LEVER:**

Place flyback lever on post in plate with screw head "C" down. Now press lever down until screw head "C" is resting on top of flyback lever spring. Hold the flyback lever down with finger, and with a thin blade screwdriver push end "A" of flyback lever spring toward outside of watch, raising it slightly so it will hook on screw head "C" of flyback lever. Now turn flyback lever toward outside of watch, while pressing down lightly, and flyback lever will snap into position. Now engage flyback lever spring between head of screw "C" and flyback lever.

**C. HAZARDS IN ASSEMBLY OF FLYBACK LEVER:**

Before pressing flyback lever down in position on post, check to see that flyback lever is not on top of trip pin or pin "A" on brake lever.

**REFERENCE:** Trip pin is Assembly 31.  
Brake lever is Assembly 19.

**D. FUNCTION OF FLYBACK LEVER:**

The functions of the flyback lever are as follows:

1. It disengages brake lever from seconds wheel.
2. It disengages the intermittent wheel from seconds wheel dart tooth.
3. Ends "A" and "B" of flyback lever contact the hearts of seconds wheel and minute register wheel, forcing these wheels and the hands attached to these wheels to a zero position.
4. Part "D" of flyback lever forces the trip pin into a position, so that pin will hook in part "E" of this lever, holding it away from center of watch.

**REFERENCE:** Intermittent lever and wheel assembly is Assembly 29.  
Seconds wheel is Assembly 25.  
Minute register wheel is Assembly 27.  
Trip pin is Assembly 31.  
Brake lever is Assembly 19.

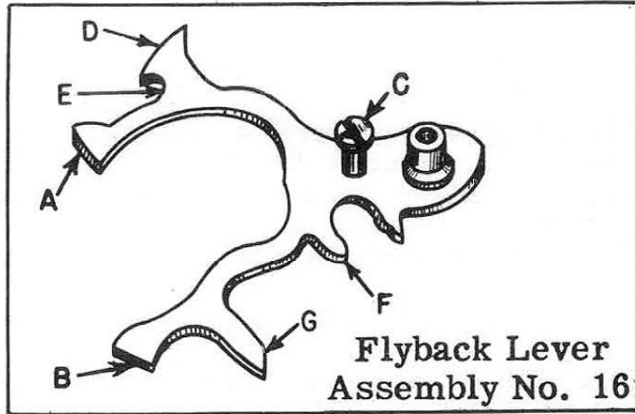

The following points on flyback lever should be slightly moistened with oil:

1. The post on which flyback lever pivots.
2. Shoulder of screw "C" on flyback lever that contacts flyback lever spring.
3. Point "D" on flyback lever that contacts trip pin.
4. Point "F" on flyback lever that contacts brake lever pin.
5. Point "G" on flyback lever that contacts eccentric stud on intermittent lever.

**TRAIN SIDE**

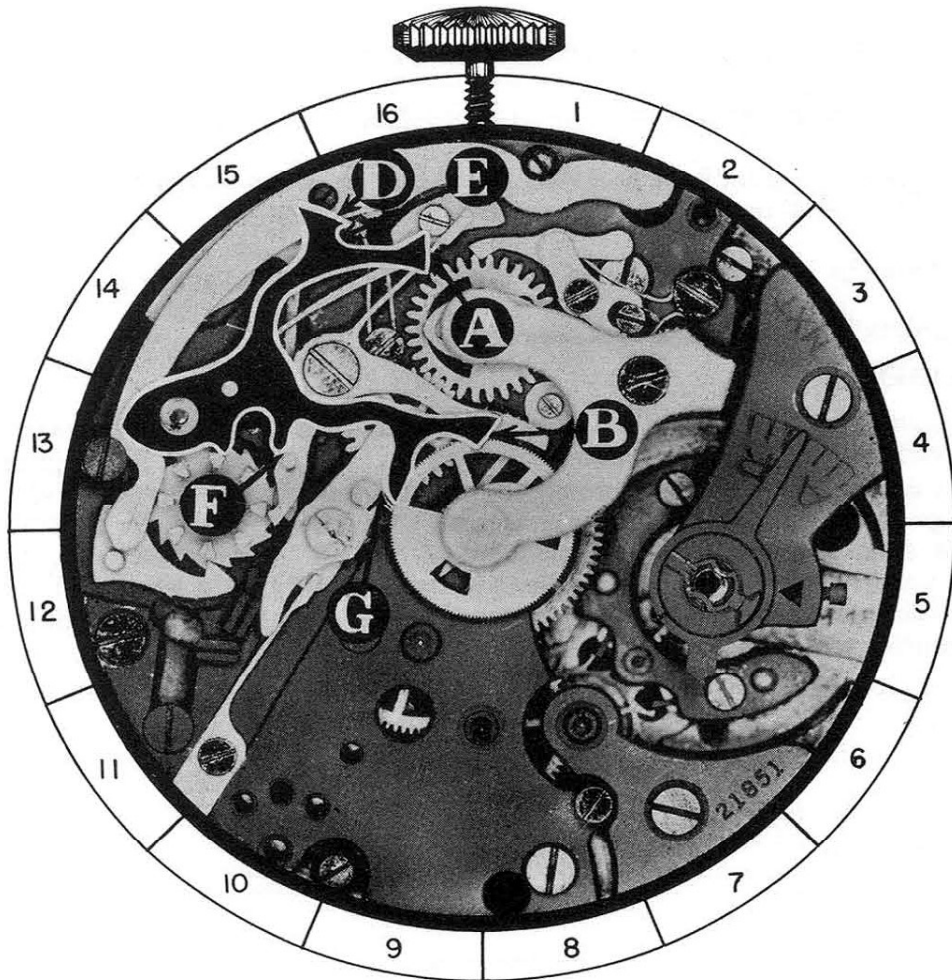

**16-A**

**A. DISASSEMBLY PROCEDURE OF ACTUATING DETENT LEVER:**

This detent is held in place by shouldered screw SS-6, and pivots under head of this screw. The shouldered screw "E", as shown in the photograph, holds pin "B" of actuating detent lever down in joint hook. Remove shouldered screw SS-6, and lift detent to remove the pin "B" from joint hook and pin "A" from hole in plate. Detent may now be lifted from movement.

(The shape of screw for this part is shown at the bottom of the page.)

**B. ASSEMBLY PROCEDURE OF ACTUATING DETENT LEVER:**

Place detent on plate, as shown in photograph. Pin "B" on detent should be in hole in joint hook and pin "A" should be down in hole in plate. Replace the shouldered screw SS-6. The detent lever should pivot freely under head of this screw. Also, the end of actuating detent lever should move freely under the head of shouldered screw "E". The position of this screw is shown in the photograph.

**C. HAZARDS IN ASSEMBLY OF ACTUATING DETENT LEVER:**

Before tightening screw on detent, check to see that pin "B" on detent is down in hole in joint hook.

**D. FUNCTION OF ACTUATING DETENT LEVER:**

The functions of this detent lever are as follows:

1. It moves the joint hook away from the center of the watch each time the end "A" of detent lever is pushed.
2. It helps to hold the joint hook in position to function properly.

**REFERENCE:** Joint hook is Assembly 18.

**REMARKS:**

The movement of end "B" of actuating detent lever away from the center of the watch is limited by the shouldered screw "E", as shown in the photograph. This limiting of the outward movement of the end "B" of detent prevents damage to the chronograph mechanism in case excess pressure is applied to the chronograph button. The movement of end "B" of actuating detent toward center of watch is limited by the detent striking the castle wheel. This limiting of the movement of end "B" of detent toward center of watch prevents lost motion when the joint hook engages with a ratchet tooth to turn the castle wheel.

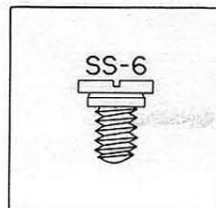

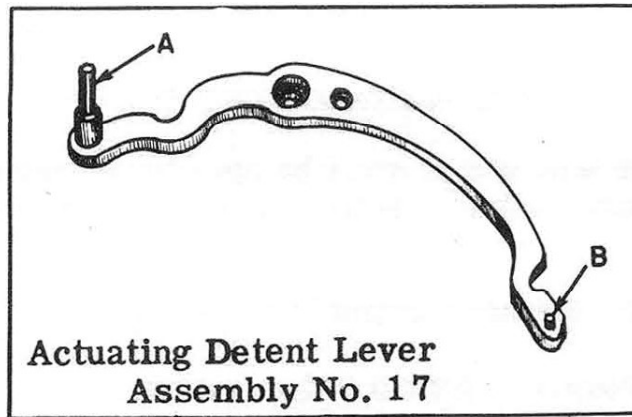

### OILING

The following points of actuating detent lever should be slightly moistened with oil:

1. The shoulder of screw on which detent pivots.
2. Pin "B" on detent lever that holds joint hook in position.

### TRAIN SIDE



17-A

**A. DISASSEMBLY PROCEDURE OF JOINT HOOK:**

The joint hook was held in place by pin "B" on actuating detent lever. The joint hook is now free on plate and may be lifted from movement.

**REFERENCE:** Actuating detent lever is Assembly 17.

**B. ASSEMBLY PROCEDURE OF JOINT HOOK:**

Place joint hook in position on plate, with pin "B" up and end "A" engaged with the ratchet teeth on castle wheel, as shown in the photograph.

**C. HAZARDS IN ASSEMBLY OF JOINT HOOK:**

Before replacing joint hook on plate, check for burrs or roughness on joint hook and plate where these parts come together, as this will cause the joint hook not to function properly.

**D. FUNCTION OF JOINT HOOK:**

The function of the joint hook is to turn the castle wheel the space of one ratchet tooth each time the end "A" of actuating detent lever is pushed.

**REMARKS:**

The end "A" of joint hook must be highly polished to function properly. Care must be taken when polishing end "A" of joint hook so as not to change its shape. If the shape of this end of joint hook is changed, it may not function properly on ratchet teeth of castle wheel.

The end "A" of actuating detent lever, being hard to depress may be caused by one or more of the following reasons:

1. The actuating detent lever spring holding too strong a tension on joint hook.
2. The castle wheel pawl holding too strong a tension on castle wheel.
3. Improper oiling of castle wheel.

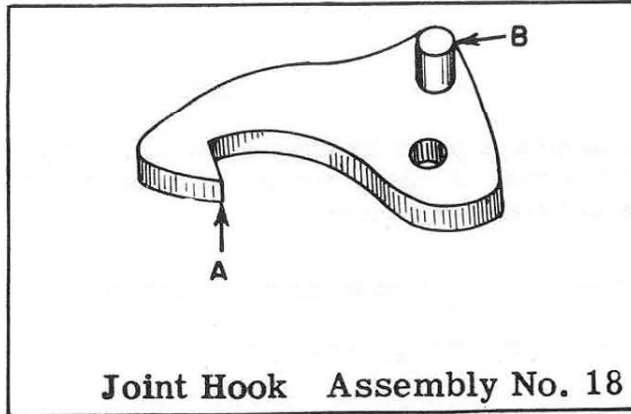

Joint Hook Assembly No. 18

### OILING

The joint hook should not be oiled.

### TRAIN SIDE

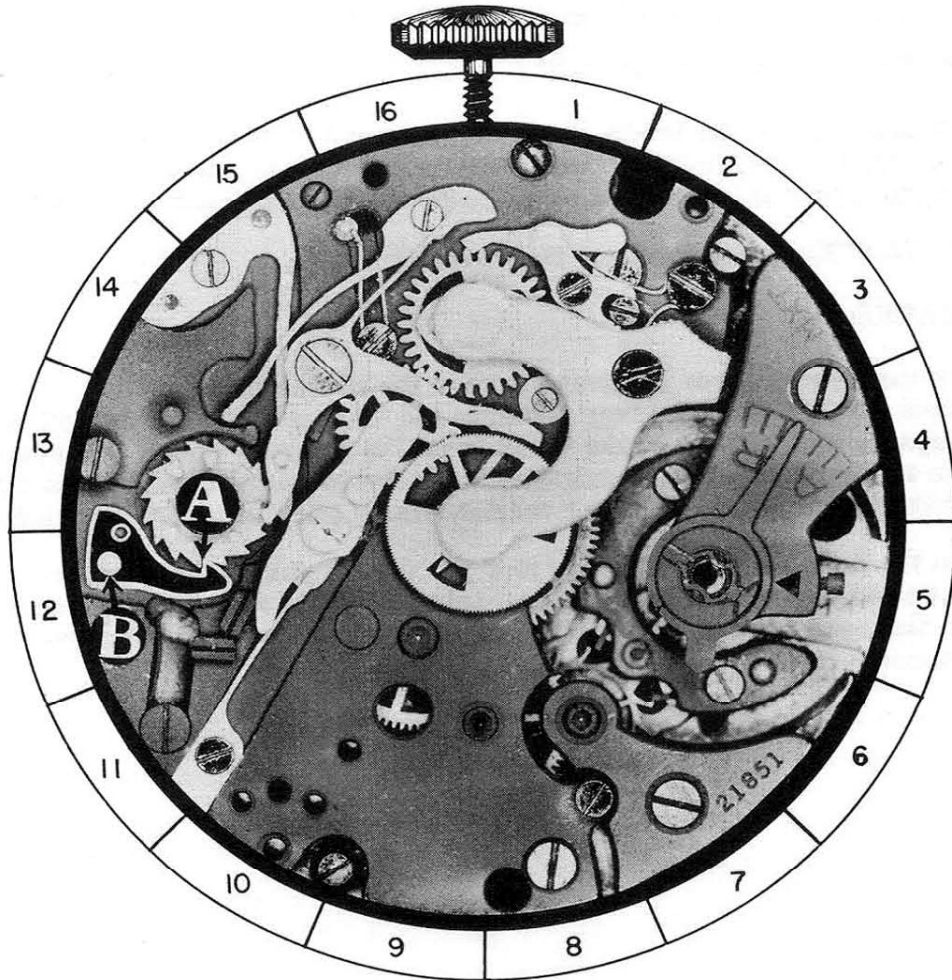

18-A

**A. DISASSEMBLY PROCEDURE OF BRAKE LEVER:**

The brake lever is held in place by shouldered screw SS-7 and pivots under head of this screw. Remove screw, and brake lever may be lifted from plate and free from movement.

(The shape of screw for this part is shown at bottom of page.)

**B. ASSEMBLY PROCEDURE OF BRAKE LEVER:**

Place the brake lever on the plate with pin "A" up and the end "C" of spring on top of screw head "F". Now replace shouldered screw SS-7, but before tightening screw, place end "C" of brake lever spring on inside of screw head "F", as shown in the photograph. Now tighten shouldered screw to hold lever in place. Check to see that lever pivots freely under head of this screw.

**C. HAZARDS IN ASSEMBLY OF BRAKE LEVER:**

Before tightening shouldered screw, check to see that end "D" of brake lever is not under or on top of seconds wheel. Also make sure that end "C" of spring is not on top of screw-head "F".

**D. FUNCTION OF BRAKE LEVER:**

The blade "E" of the brake lever engages end "D" of this lever with the seconds wheel, holding this wheel in a stationary position, when the brake lever is permitted to do so by the chronograph mechanism.

**REFERENCE:** Seconds wheel is Assembly 25.

**REMARKS:**

When the flyback lever is forced toward the center of the watch, the surface "F" on flyback lever contacts pin "A" on brake lever. This disengages end "D" on brake lever from the seconds wheel. Naturally, the brake lever must be disengaged from the seconds wheel, at this time, so that flyback lever can bring seconds wheel back to a zero position.

When the castle wheel is turned to a position to permit intermediary wheel to engage with the seconds wheel, the castle wheel, at this same time, disengages the brake lever from the seconds wheel. This frees the seconds wheel so that it can turn.

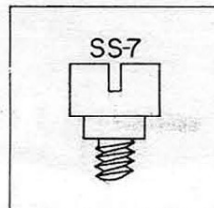



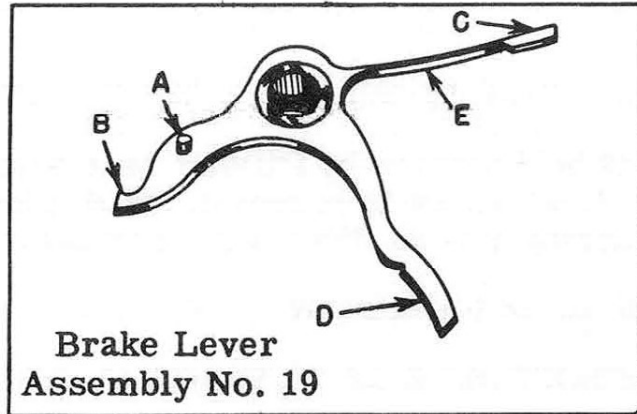

### OILING

The shoulder of screw, on which brake lever pivots, should be slightly moistened with oil.

### TRAIN SIDE

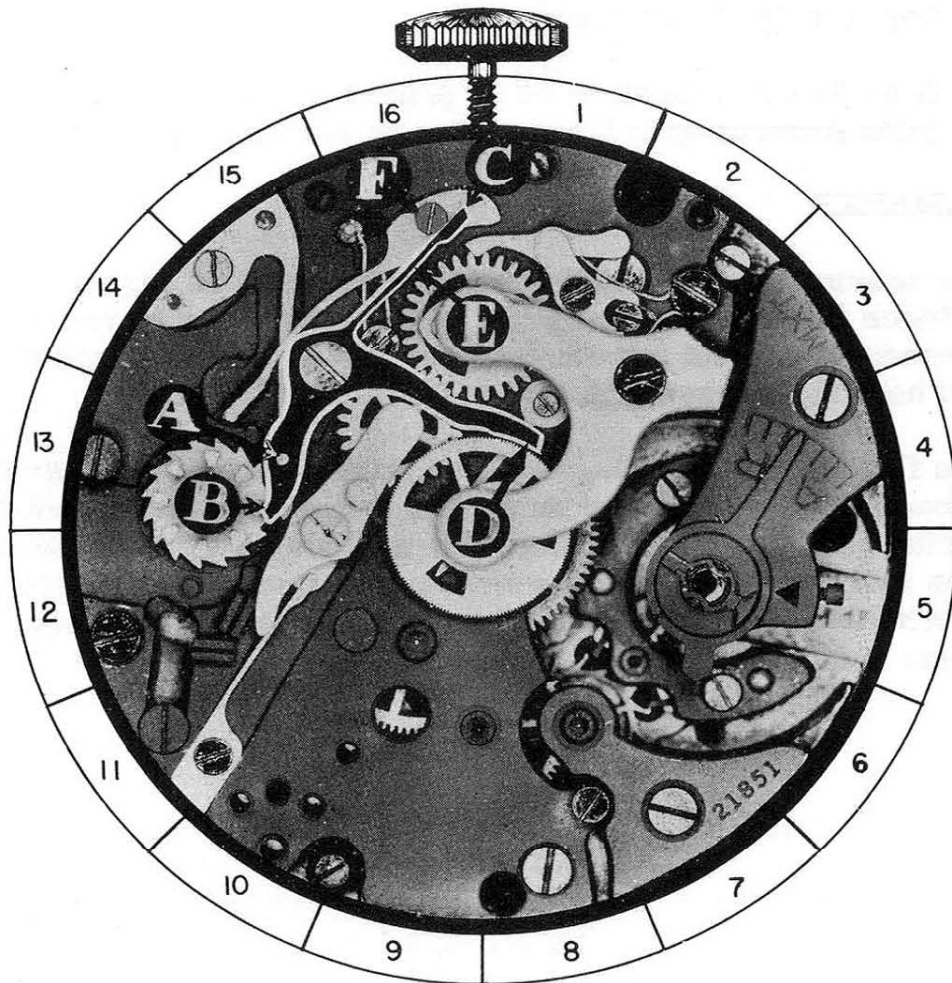

19-A.

**A. DISASSEMBLY PROCEDURE OF FLYBACK LEVER SPRING:**

This spring is held in place by fillister head screw FS-3 and steady pins. After screw is removed, steady pins will be free in plate, and spring may be lifted from movement.

(The shape of screw for this part is shown at bottom of page.)

**B. ASSEMBLY PROCEDURE OF FLYBACK LEVER SPRING:**

Place spring in place on plate with steady pins in proper holes. Replace fillister head screw FS-3.

**C. FUNCTION OF FLYBACK LEVER SPRING:**

The functions of this spring are as follows:

1. It forces the flyback lever in toward the center of watch and holds it in this position until the flyback lever is disengaged by the castle wheel.
2. It holds the flyback lever in proper position on post in plate preventing it from riding up and coming out of place.

**REMARKS:**

The tension of the flyback lever spring must be strong enough to force the ends "A" and "B" of flyback lever to return the seconds wheel and minute register wheel to a zero position, and hold these wheels in a zero position.

The flyback lever spring must be strong enough to cause the flyback lever to function properly, yet, excess tension of this spring on flyback lever should be avoided, as this excess tension will cause the castle wheel to be unnecessarily hard to turn when it disengages the flyback lever from the seconds wheel and minute register wheel.

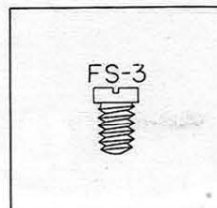

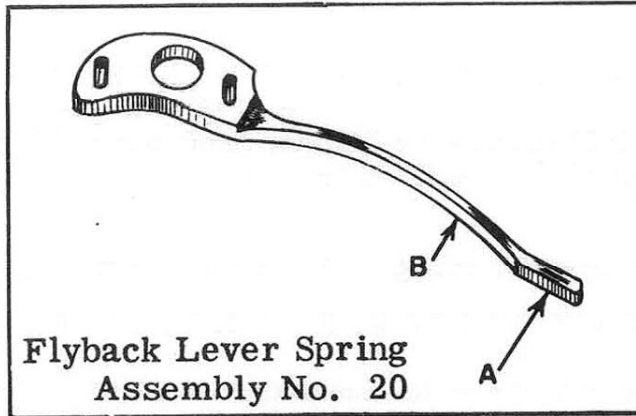

### OILING

End "A" of flyback lever spring should be oiled after replacing flyback lever.

### TRAIN SIDE

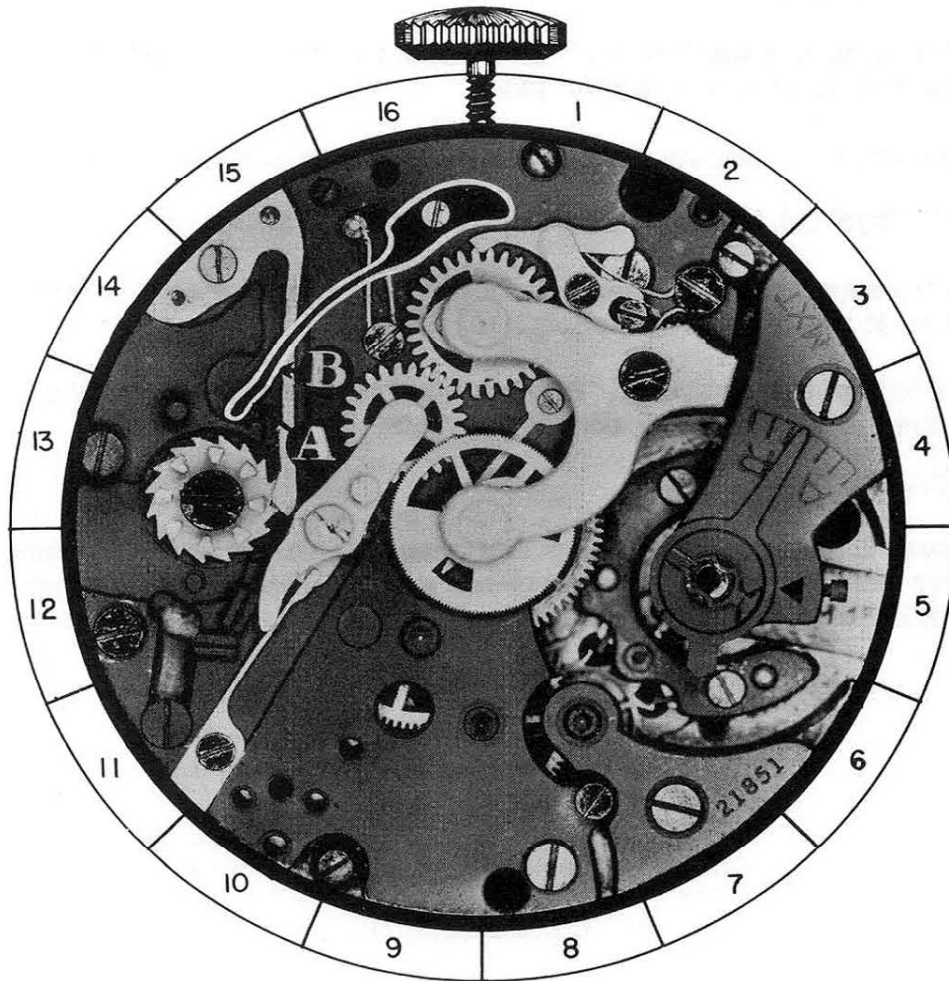

20-A

**A. DISASSEMBLY PROCEDURE OF MINUTE REGISTER PAWL BRIDGE:**

This bridge is held in place by fillister head screw FS-4. After screw is removed, bridge may be lifted from post in plate and withdrawn from eccentric stud "D".

(The shape of screw for this part is shown at bottom of page.)

**B. ASSEMBLY PROCEDURE OF MINUTE REGISTER PAWL BRIDGE:**

Place bridge in position so that eccentric stud "D" is in slot "B" of bridge. Now place hole in bridge over shoulder on post in plate. Press bridge down with pin "A" in hole in bushing in minute register pawl. Replace fillister head screw FS-4 to hold bridge stationary. The minute register pawl should turn freely after bridge is replaced.

**REFERENCE:** Minute register pawl is Assembly 22.

**C. HAZARDS IN ASSEMBLY OF MINUTE REGISTER PAWL BRIDGE:**

1. Before tightening screw, check to see that minute register pawl spring is not under minute register pawl.
2. Check to see that pin "A" on minute register pawl bridge is down in hole in minute register pawl.

**REFERENCE:** Minute register pawl spring is Assembly 23.

**D. FUNCTION OF MINUTE REGISTER PAWL BRIDGE:**

The function of this bridge is to hold the minute register pawl in position, so it can function properly.

This bridge is adjustable. Explanation for adjusting this bridge will be found under adjusting eccentric studs.

**REMARKS:**

Be sure that the screwdrivers are properly sharpened, as a screwdriver that is improperly sharpened may slip and cause damage to the delicate parts of the chronograph.

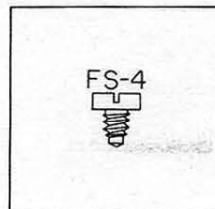

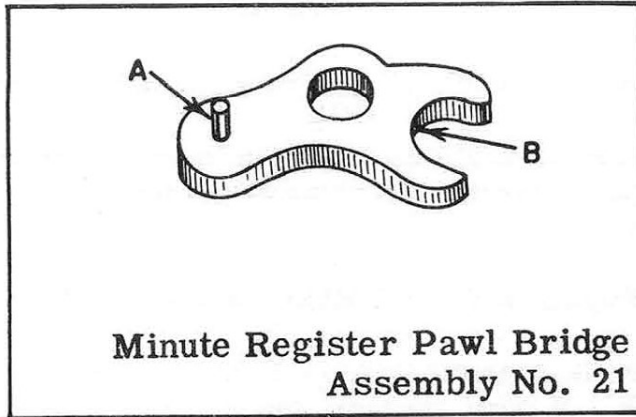

Minute Register Pawl Bridge  
Assembly No. 21

### OILING

Pin "A" on minute register pawl bridge, that holds minute register pawl in position, should be slightly moistened with oil before replacing this bridge.

### TRAIN SIDE

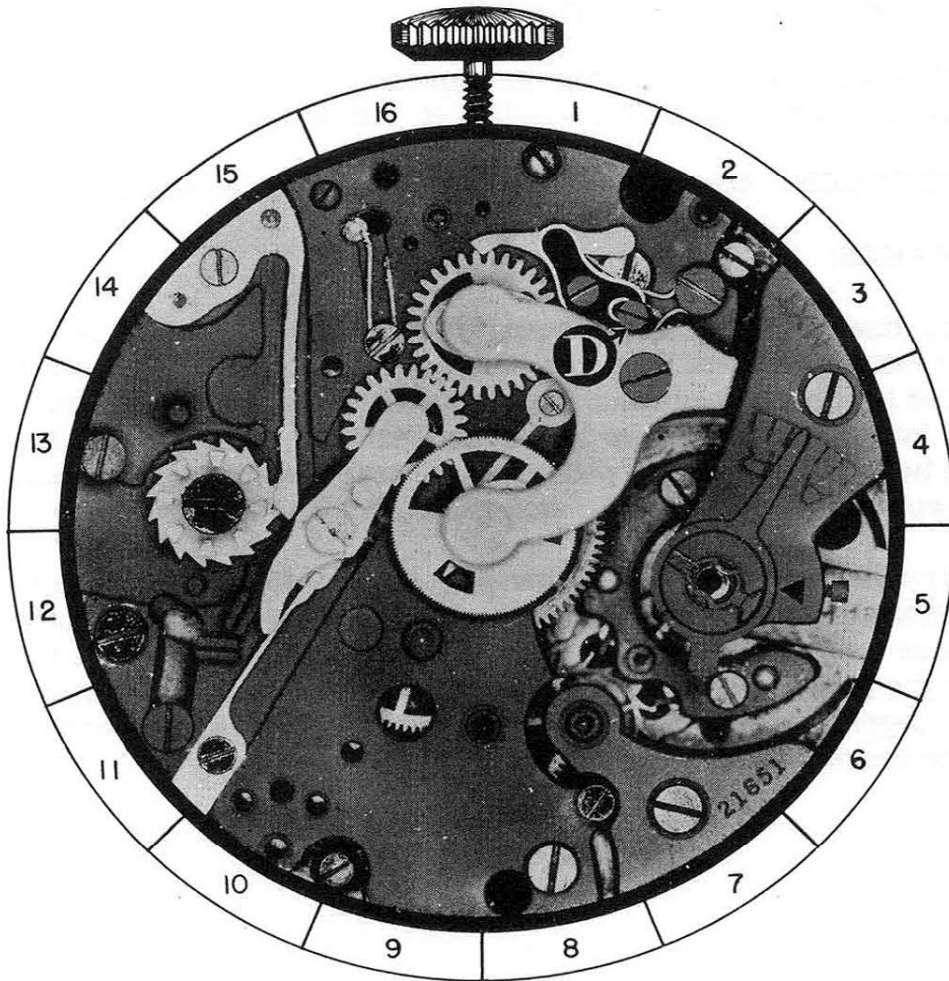

21-A

**A. DISASSEMBLY PROCEDURE OF MINUTE REGISTER PAWL:**

This pawl is free on plate as it was held in position by the minute register pawl bridge. To remove the pawl, simply lift it from the plate.

**B. ASSEMBLY PROCEDURE OF MINUTE REGISTER PAWL:**

Place the pawl in proper place on plate, as shown in photograph, so that end "A" of pawl contacts the teeth on minute register wheel. This part is held in place by the minute register pawl bridge, which is the next part to be replaced.

**C. FUNCTION OF MINUTE REGISTER PAWL:**

The functions of the minute register pawl are as follows:

1. This pawl correctly spaces the turning of the minute register wheel. This assures that the minute register wheel will not set at an incorrect position.
2. It holds a tension on minute register wheel, so that a bump or jar cannot alter the position of this wheel.

**REFERENCE:** Minute register pawl bridge is Assembly 21.

**REMARKS:**

When disassembling the chronograph, each part should be carefully examined as it is removed from the movement. Each part should be checked against the isometric drawing, to see that the part is the correct shape and is not broken. Each part should also be checked for any pits of rust, roughness, or burrs and for worn parts, which may cause the part not to work properly.

The replacement of a defective part in the chronograph may necessitate complete disassembly of the chronograph. Through a close examination of each part, you will soon become familiar with the parts of the chronograph. This will enable you to quickly recognize a defective part and repair it before replacing it in the chronograph.

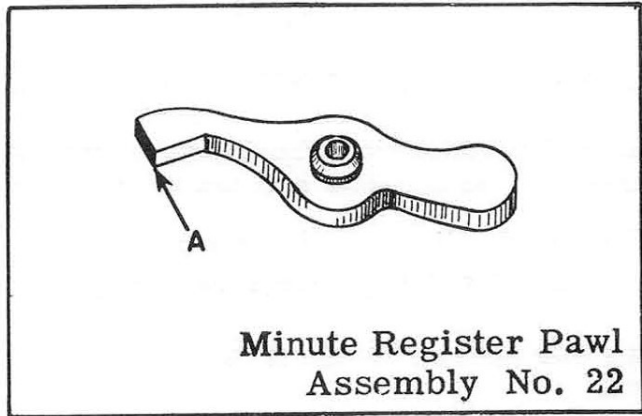

OILING

The minute register pawl should not be oiled.

TRAIN SIDE



22-A

**A. DISASSEMBLY PROCEDURE OF MINUTE REGISTER PAWL SPRING:**

This spring is held in place by a shouldered screw, SS-8. Remove screw and spring is free on plate and can be lifted from movement.

(The shape of screw for this part is shown at bottom of page.)

**B. HAZARDS IN DISASSEMBLY OF MINUTE REGISTER PAWL SPRING:**

When removing this spring, handle it carefully, as it is delicate and easily damaged.

**C. ASSEMBLY PROCEDURE OF MINUTE REGISTER PAWL SPRING:**

Place spring over proper hole in plate, as shown in photograph, with end "A" of spring under seconds wheel and minute register wheel bridge. Replace shouldered screw SS-8. Spring should turn freely under the head of screw.

**REFERENCE:** Seconds wheel and minute register wheel bridge is Assembly 24.

**D. HAZARDS IN ASSEMBLY OF MINUTE REGISTER PAWL SPRING:**

Handle spring carefully when replacing it, as it is easily damaged. Before tightening screw, be sure spring is not under shoulder of screw but around the shoulder.

**E. FUNCTION OF MINUTE REGISTER PAWL SPRING:**

The function of this spring is to hold a tension on the minute register pawl, so the pawl engages properly with the teeth of the minute register wheel.

**REMARKS:**

The minute register pawl spring must hold enough tension on minute register pawl, so it will function properly, as stated on page 22. Yet the tension must not be excessive, as too strong a tension on the pawl will cause the minute register wheel to be unnecessarily hard to turn, and may cause the watch to stop.

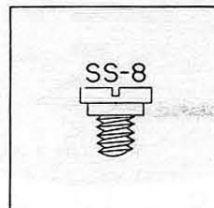



Minute Register  
Pawl Spring  
Assembly No. 23

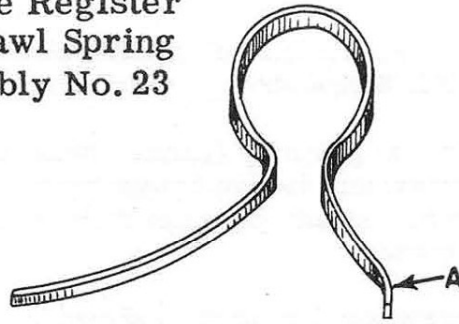

### OILING

The minute register pawl spring should be slightly moistened with oil at the point it contacts minute register pawl.

### TRAIN SIDE

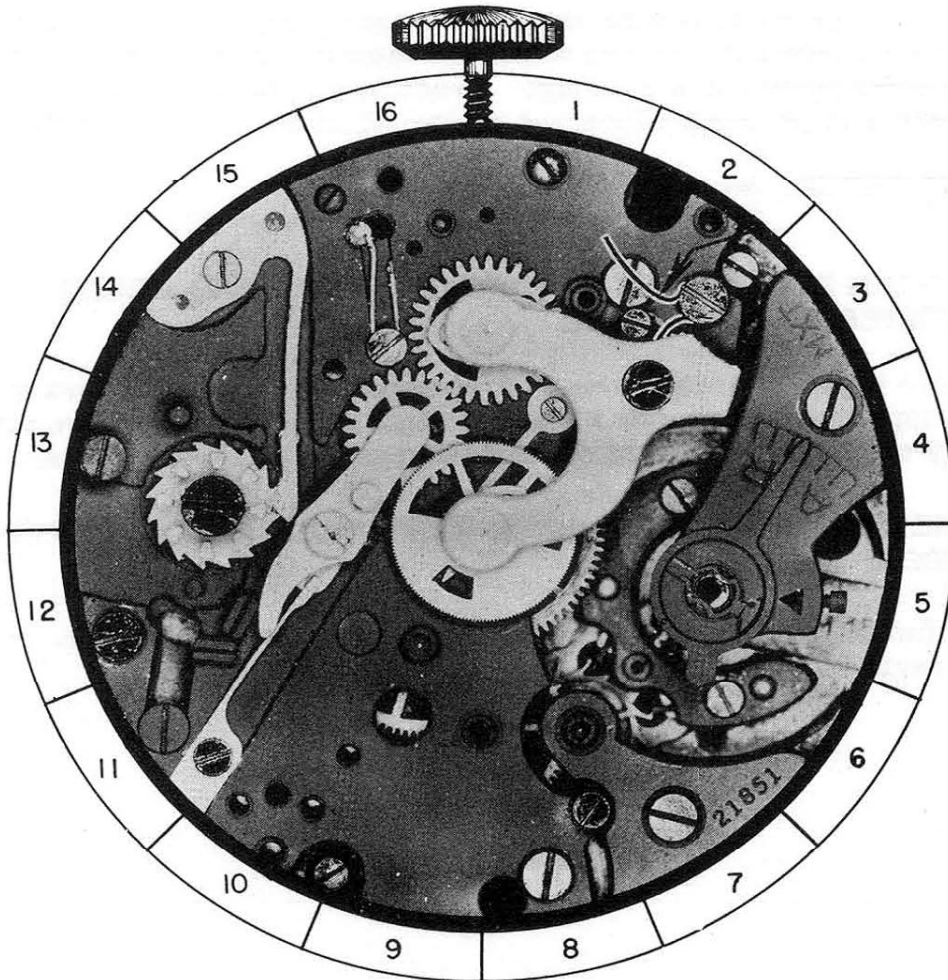

23-A

**A. DISASSEMBLY PROCEDURE OF SECONDS WHEEL AND MINUTE REGISTER WHEEL BRIDGE:**

This bridge is held in place by fillister head screw FS-5 and steady pins. Remove screw, and loosen bridge from plate with a thin blade screw-driver. When steady pins are free in plate, bridge may be lifted from movement.

(The shape of screw for this part is shown at bottom of page.)

**B. HAZARDS IN DISASSEMBLY OF SECONDS WHEEL AND MINUTE REGISTER WHEEL BRIDGE:**

When loosening and removing bridge from plate, avoid any twisting or turning of bridge, as this may damage pivots or chip the jewels. The screw-driver should be carefully used in loosening bridge from plate, to prevent marring of bridge or plate.

**C. ASSEMBLY PROCEDURE OF SECONDS WHEEL AND MINUTE REGISTER WHEEL BRIDGE:**

Place bridge on plate with steady pins over proper holes in plate. Place top pivots of seconds wheel and minute register wheel, so they will enter jewel holes in bridge. Press bridge down with back of tweezers to proper position, and replace fillister head screw FS-5.

**REFERENCE:** Seconds wheel is Assembly 25.  
Minute register wheel is Assembly 27.

**D. HAZARDS IN ASSEMBLY OF SECONDS WHEEL AND MINUTE REGISTER WHEEL BRIDGE:**

Before pressing bridge down to proper position on plate, check to see that top pivots of seconds wheel and minute register wheel are entering jewel holes. This will prevent damage to pivots and jewels.

**E. FUNCTION OF SECONDS WHEEL AND MINUTE REGISTER WHEEL BRIDGE:**

The function of this bridge is to hold the seconds wheel and the minute register wheel in position, so they can function properly.

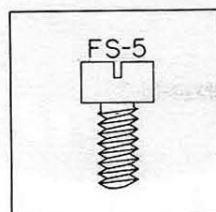

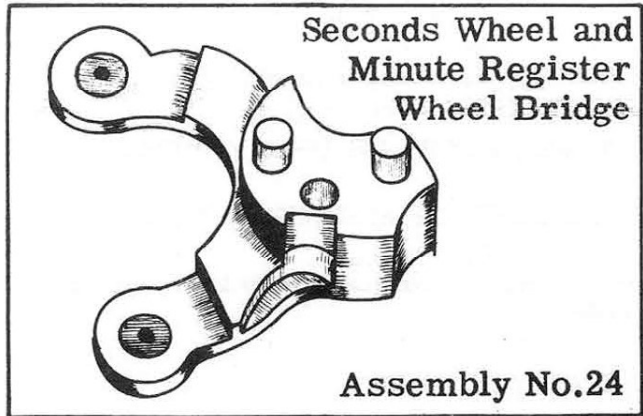

### OILING

The pivots in the jewels in this bridge should be oiled as you would properly oil a train pivot in a watch.

### TRAIN SIDE



**A. DISASSEMBLY PROCEDURE OF SECONDS WHEEL:**

To remove this wheel, simply lift it out of place.

**B. ASSEMBLY PROCEDURE OF SECONDS WHEEL:**

Place the seconds wheel in position with the long pivot "A" down in hollow center pinion.

**C. FUNCTION OF SECONDS WHEEL:**

The functions of the seconds wheel are as follows:

1. It registers the seconds that have elapsed since the beginning of the registration. This is done by a hand being attached to the long pivot on the seconds wheel.
2. The seconds wheel must move the minute register wheel forward one tooth each time the seconds wheel makes one revolution. This is done by a dart tooth "C" attached to the seconds wheel. This dart tooth meshes with the teeth on the intermittent wheel, which, in turn, move the minute register wheel one tooth.
3. The seconds wheel must return the seconds hand to zero position, when the flyback lever is brought in contact with the heart on this wheel. Seconds wheel heart is shown as "B" on the isometric drawing.

**REFERENCE:** Seconds wheel dart tooth is Assembly 25-C.  
Intermittent wheel is Assembly 29-A.  
Minute register wheel is Assembly 27.  
Flyback lever is Assembly 16.

**REMARKS:**

When the flyback lever is forced toward the center of the watch by the flyback lever spring, the seconds wheel and minute register wheel should be checked to see if either of these wheels will turn. The minute register wheel should turn slightly at this point, but the seconds wheel should be held very tight by the flyback lever. It is most essential for the seconds wheel to be held stationary by the flyback lever at a zero position. In the case of the minute register wheel, it does not have to be held absolutely stationary by the flyback lever. The minute register pawl will serve this purpose. The only thing that the minute register wheel should be checked for is to see that the minute register wheel will not turn far enough to one side or the other to let the minute register pawl drop in to another space between the next two teeth. This will assure that the minute register wheel will always be brought back to a zero position.

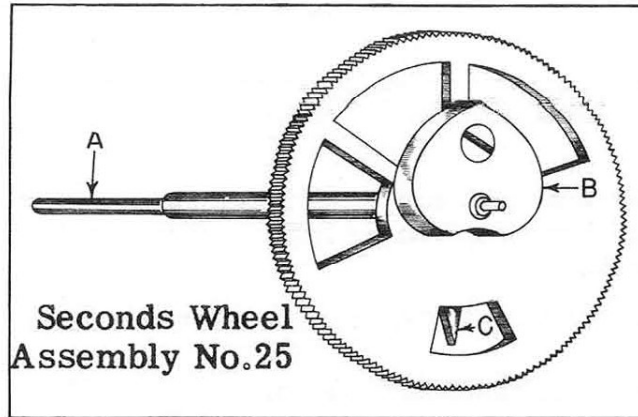

### OILING

The top pivot of seconds wheel should be oiled after bridge for this wheel is placed in watch.

### TRAIN SIDE

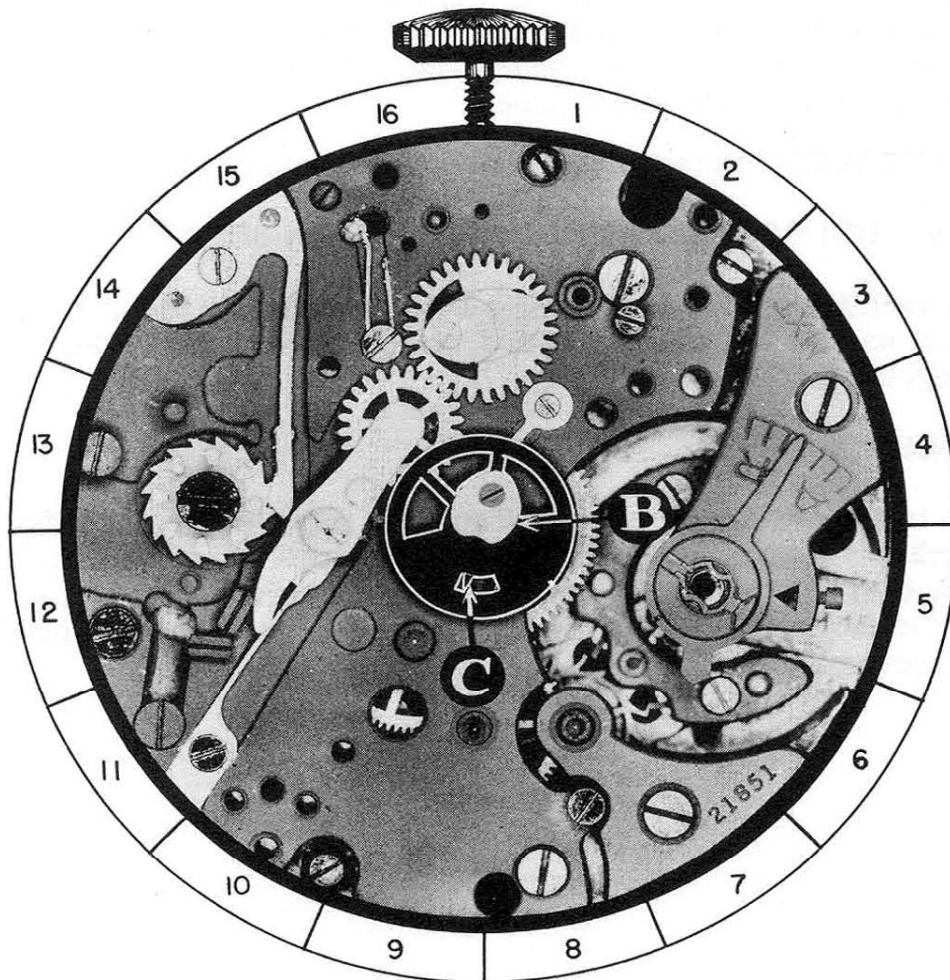

25-A

**A. DISASSEMBLY PROCEDURE OF SECONDS WHEEL TENSION SPRING:**

This spring is held in place by fillister head screw FS-6. Remove screw, and spring will be free on plate and may be lifted from movement.

(The shape of screw for this part is shown at bottom of page.)

**B. HAZARDS IN DISASSEMBLY OF SECONDS WHEEL TENSION SPRING:**

This tension spring should be carefully handled, as it is very delicate and can be easily damaged.

**C. ASSEMBLY PROCEDURE OF SECONDS WHEEL TENSION SPRING:**

Place tension spring over proper hole in plate with the highly polished end "A" up. Replace fillister head screw FS-6. After tightening this screw, make sure that end "A" of spring is in the position shown in the photograph, so that it cannot possibly contact the seconds wheel post.

**REFERENCE:** Seconds wheel post is Assembly 25A.

**D. FUNCTION OF SECONDS WHEEL TENSION SPRING:**

The function of this spring is to hold a tension on the seconds wheel, so this wheel turns with a smooth, even action with no irregular jumping or jerking.

**REMARKS:**

The tension of spring on wheel must be adjusted, so when the watch is running, the seconds hand advances  $1/5$  of a second for each beat of the watch. If the tension of spring is too strong, it may cause watch to stop, or if the tension is not strong enough, the movement of the seconds hand may be irregular.

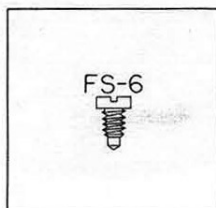

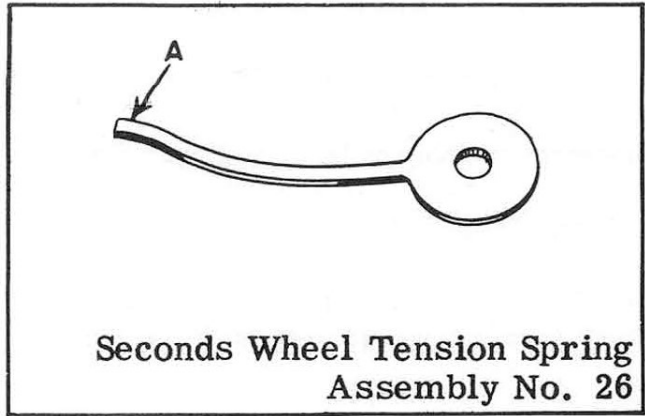

**OILING**

The seconds wheel tension spring should not be oiled.

**TRAIN SIDE**

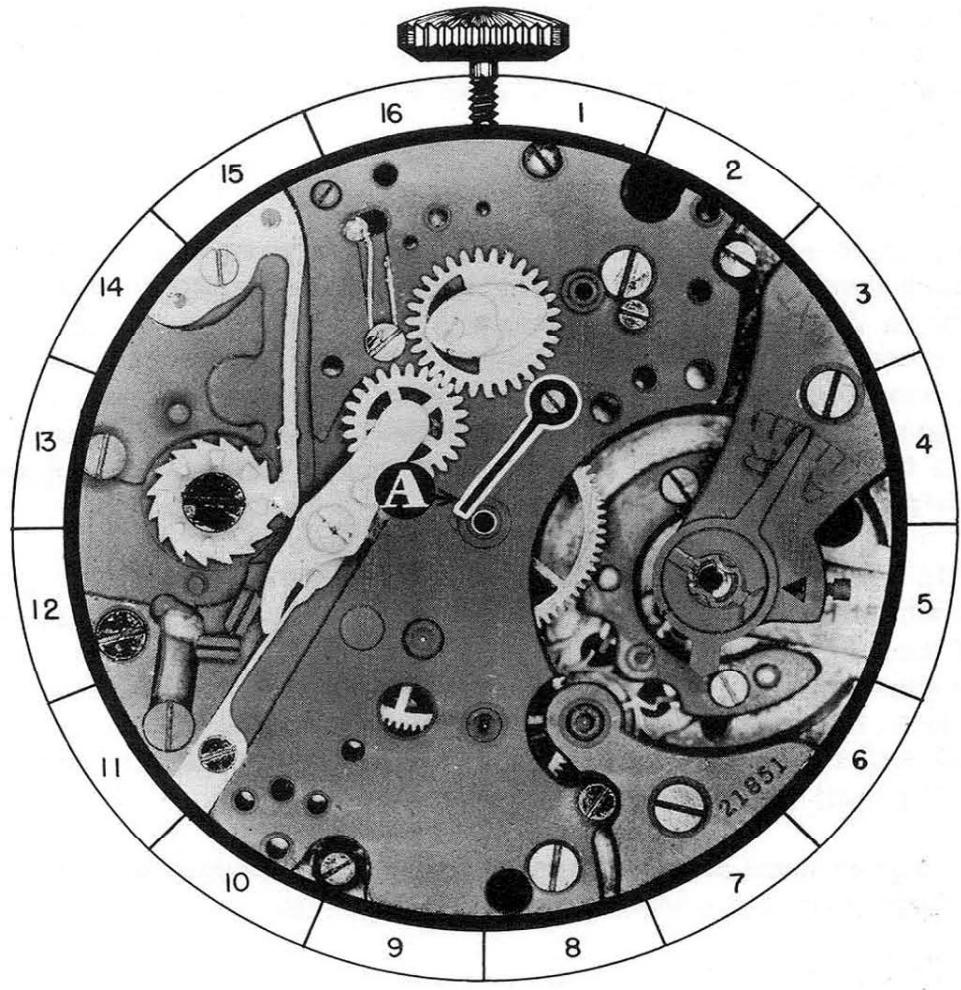

**A. DISASSEMBLY PROCEDURE OF MINUTE REGISTER WHEEL:**

To remove this wheel, simply lift it out of place.

**B. HAZARDS IN DISASSEMBLY OF MINUTE REGISTER WHEEL:**

When removing this wheel, lift wheel straight up out of watch, as any twisting may bend or break the pivot on the minute register wheel.

**C. ASSEMBLY PROCEDURE OF MINUTE REGISTER WHEEL:**

Place the minute register wheel in its proper position in the watch, as shown in the photograph, with the long post "A" of this wheel down in plate.

**D. FUNCTION OF MINUTE REGISTER WHEEL:**

The function of the minute register wheel is to record the minutes that have elapsed since the beginning of the registration. This is done by means of a hand being attached to staff "A" of this wheel. The heart "B" is used to return the wheel to a zero position.

**REMARKS:**

The minute register wheel is returned to a zero position by the flyback lever contacting the heart on minute register wheel. The heart on this wheel is set eccentric. When the flat end of flyback lever contacts the eccentric heart, it forces the heart to turn. The heart will turn until the flat end of flyback lever sets across the two lobes at top of heart. With the pressure equalized at these two points, it will turn no further and this would be a zero position.

If this wheel has turned less than 160 degrees from a zero position when the flyback lever is brought in contact with the heart, it will turn in the opposite direction to which it was turning to bring this wheel back to a zero position. On the other hand, if the wheel is turned past 160 degrees from a zero position, the flyback lever will force the heart to continue to turn in the direction it was turning until it reaches a zero position.

The degree used above is approximate, as this degree varies in most chronographs from 150 to 170 degrees.

**REFERENCE:** Flyback lever is Assembly 16.



**Minute Register Wheel  
Assembly No. 27**

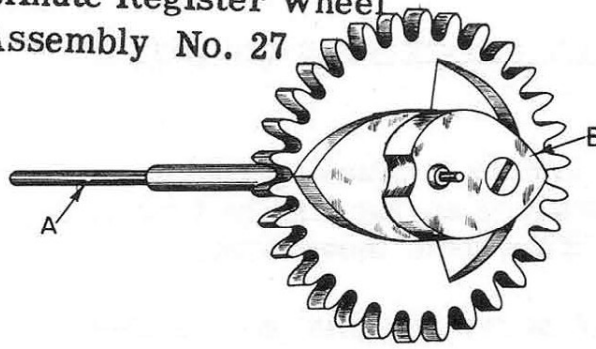

**OILING**

The top pivot of minute register wheel should be oiled after the bridge for this wheel is placed in watch.

**TRAIN SIDE**

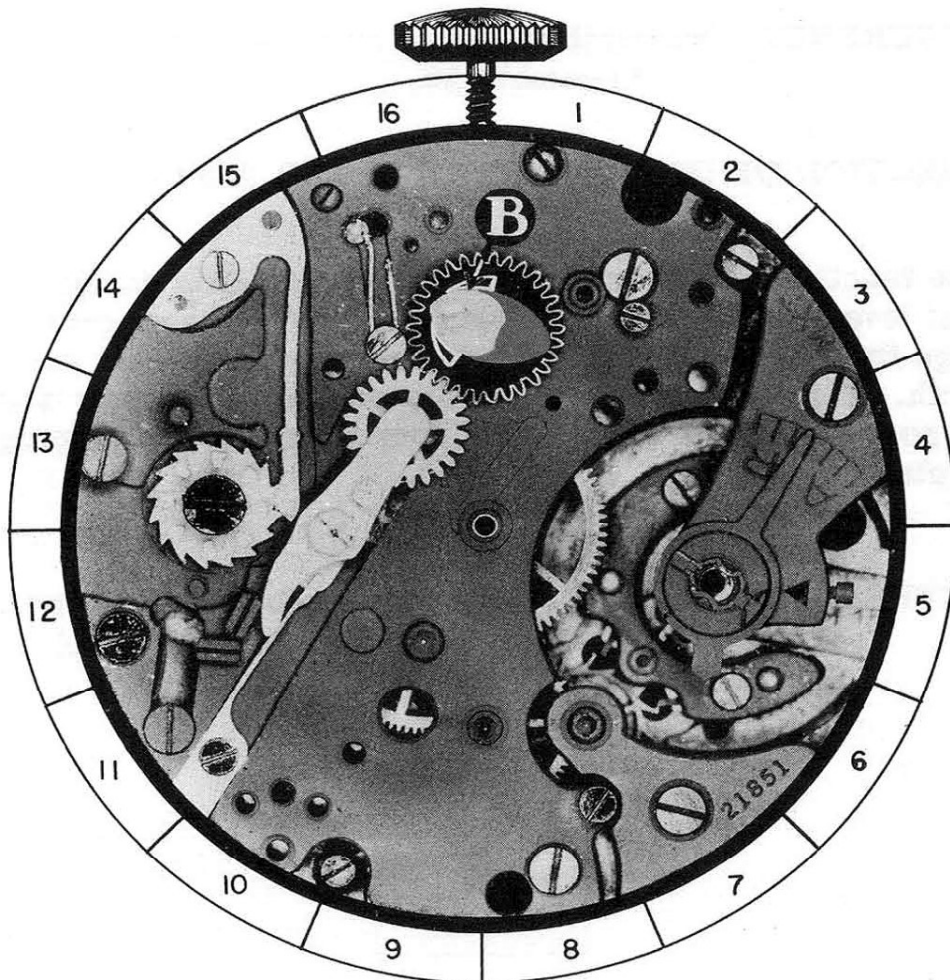

**27-A**

**A. DISASSEMBLY PROCEDURE OF INTERMITTENT LEVER SPRING:**

This spring is held in place by fillister head screw FS-7. Remove screw, and spring will be free in recess in plate, and may be lifted from movement.

(The shape of screw for this part is shown at bottom of page.)

**B. ASSEMBLY PROCEDURE OF INTERMITTENT LEVER SPRING**

Place spring in recess in plate, with hole in spring over proper hole in recess in plate, as shown in the photograph. Be sure end "A" of spring is on top of lip "B" of intermittent lever and wheel assembly. Replace fillister head screw FS-7.

**REFERENCE:** Intermittent lever and wheel assembly is Assembly 29.

**C. FUNCTION OF INTERMITTENT LEVER SPRING:**

The function of this spring is to hold a tension on intermittent lever. This tension forces the intermittent lever to engage the intermittent wheel with the seconds wheel dart tooth. This spring also holds the intermittent lever down on post on plate, preventing it from riding up and coming out of place.

**REFERENCE:** Seconds wheel dart tooth is Assembly 25-C. Intermittent wheel is Assembly 29-A.

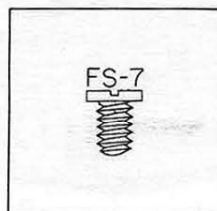

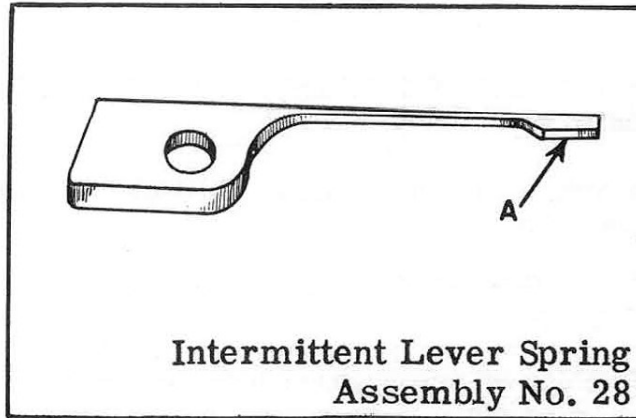

### OILING

End "A" of intermittent lever spring should be slightly moistened with oil at point it contacts intermittent lever.

### TRAIN SIDE

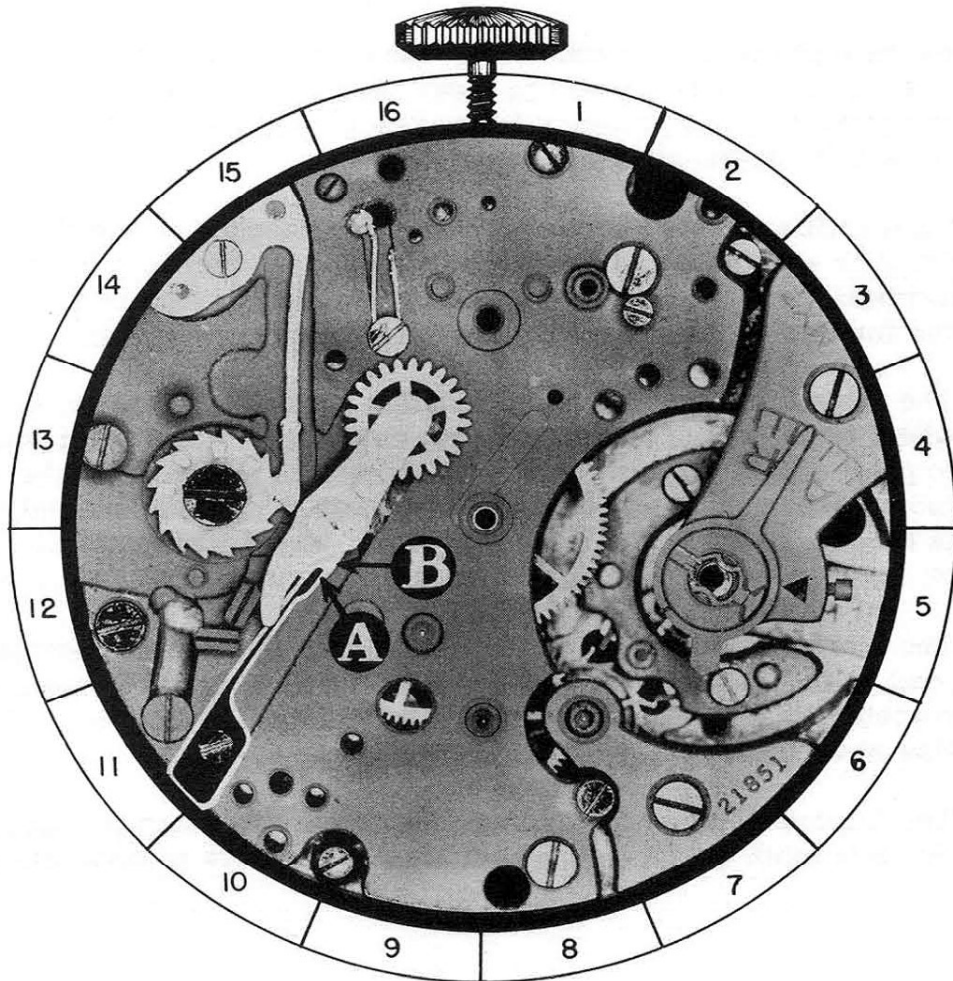

28-A

**A. DISASSEMBLY PROCEDURE OF INTERMITTENT LEVER AND WHEEL ASSEMBLY:**

This assembly pivots on post in plate. Lift assembly from post and free of movement.

**B. ASSEMBLY PROCEDURE OF INTERMITTENT LEVER AND WHEEL ASSEMBLY:**

Place hole in bushing of intermittent lever over proper post in plate and press lever down in position. Assembly should pivot freely on post.

**C. FUNCTION OF INTERMITTENT LEVER AND WHEEL ASSEMBLY:**

The function of this lever is to engage and disengage the intermittent wheel with the seconds wheel dart tooth.

**REFERENCE:** Seconds wheel dart tooth is Assembly 25-C.

**REMARKS:**

When the flyback lever returns the wheels to a zero position, it forces the intermittent lever to move intermittent wheel away from center of watch, making it impossible for dart tooth to touch the intermittent wheel at this time.

The intermittent wheel should be carefully checked to see that it has proper endshake and spins freely in the intermittent lever. This wheel must, of necessity, spin freely, as any excess friction on the intermittent wheel may cause the following errors:

1. The intermittent wheel teeth meshing with the minute register wheel teeth, which are stationary, cause the intermittent wheel to pivot and turn on its axis, as it moves to engage with the dart tooth. When engaging with the dart tooth if the intermittent wheel is binding, it turns the minute register wheel instead of turning on its axis and may result in an error in register of minutes.
2. The intermittent wheel binding may cause the minute register pawl to be unable to correctly space the turning of the minute register wheel, which may result in minute register hand setting at an incorrect position.
3. The intermittent wheel binding may cause the watch to stop, as the dart tooth on seconds wheel may not be able to turn this wheel.

Intermittent Lever and  
Wheel Assembly

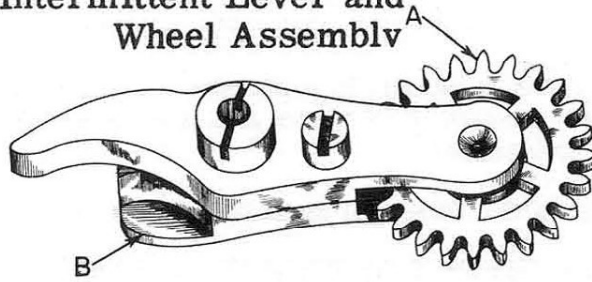

Assembly No. 29

OILING

The post on which intermittent lever and wheel assembly pivots should be slightly moistened with oil.

TRAIN SIDE

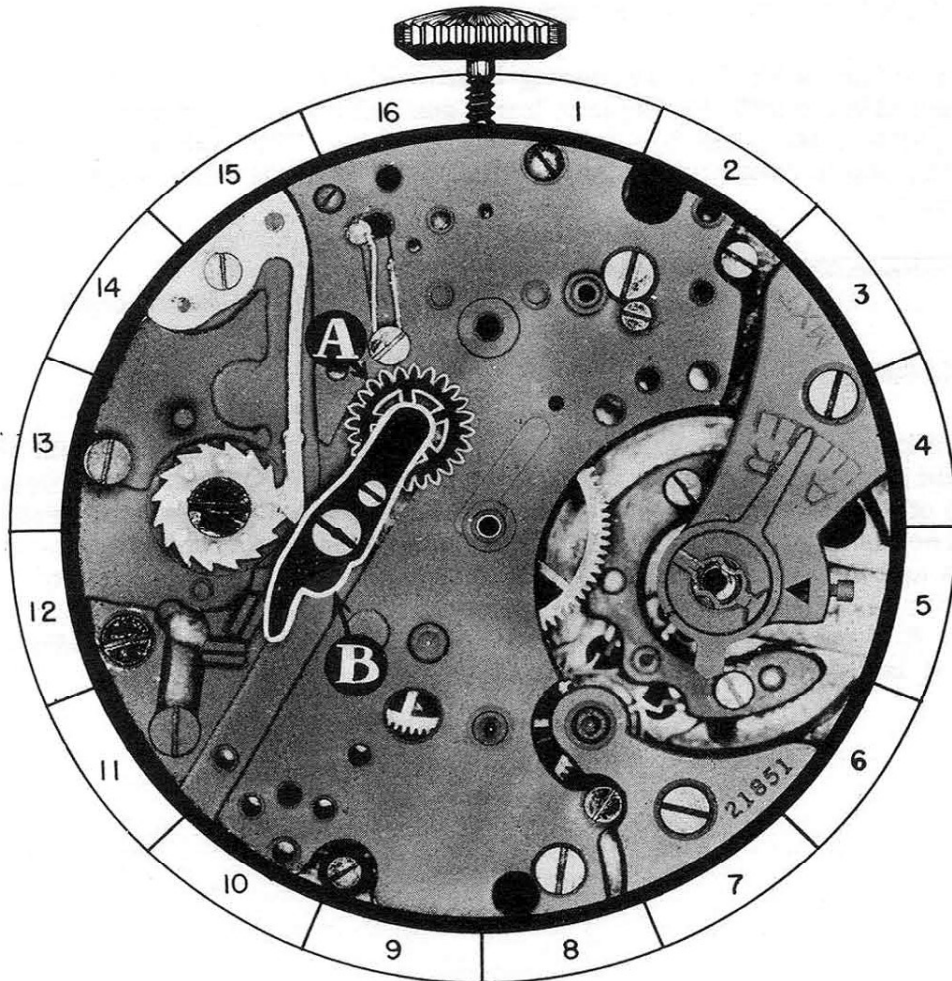

29-A

**A. DISASSEMBLY PROCEDURE OF TRIP PIN SPRING:**

This spring fits down in recess in plate, and is held in place by fillister head screw FS-8. Remove this screw, and spring may be lifted out of recess and free of movement.

(The shape of screw for this part is shown at bottom of page.)

**B. HAZARDS IN DISASSEMBLY OF TRIP PIN SPRING:**

To avoid loss of spring, place finger over loop "B", grip spring near end "A" with tweezers, and lift it out of recess in plate.

**C. ASSEMBLY PROCEDURE OF TRIP PIN SPRING:**

Place the spring in recess in plate with end "A" of spring in contact with trip pin. Part "B" of spring should be placed over screw hole in recess. Hold spring in place with finger, and push end "C" down in recess with pegwood. Replace fillister head screw FS-8.

**REFERENCE:** Trip pin is Assembly 31.

**D. FUNCTION OF TRIP PIN SPRING:**

The function of the trip pin spring is to hold a tension on the trip pin to engage this pin with the flyback lever, and hold it engaged until it is disengaged by push piece for setting back to zero. This spring also holds the trip pin in proper position in plate, preventing it from coming out of place.

**REFERENCE:** Flyback lever is Assembly 16.  
Push piece for setting back to zero is Assembly 7.

**REMARKS:**

The trip pin spring is held in place by a fillister head screw. This screw should not hold the spring tight, but the spring should work freely under head of screw. The width of the trip pin spring is less than the depth of the recess in plate; this permits the fillister head screw to tighten on plate and the spring work freely in the recess under head of screw.

When it is necessary to replace a trip pin spring, be sure the width of spring is slightly less than the depth of recess in plate.

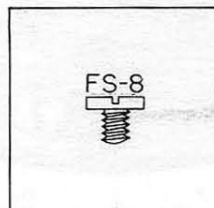

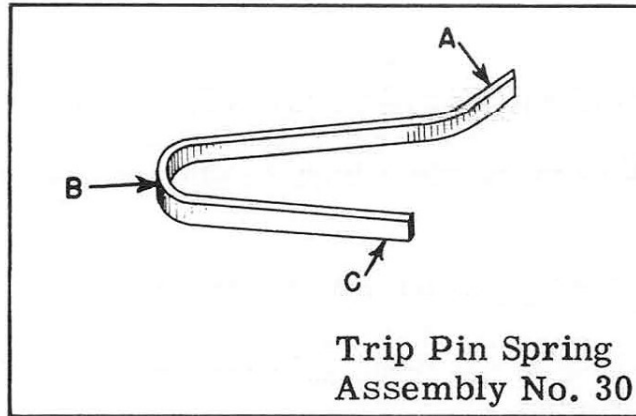

### OILING

End "A" of trip pin spring, where it contacts trip pin, should be slightly moistened with oil.

### TRAIN SIDE

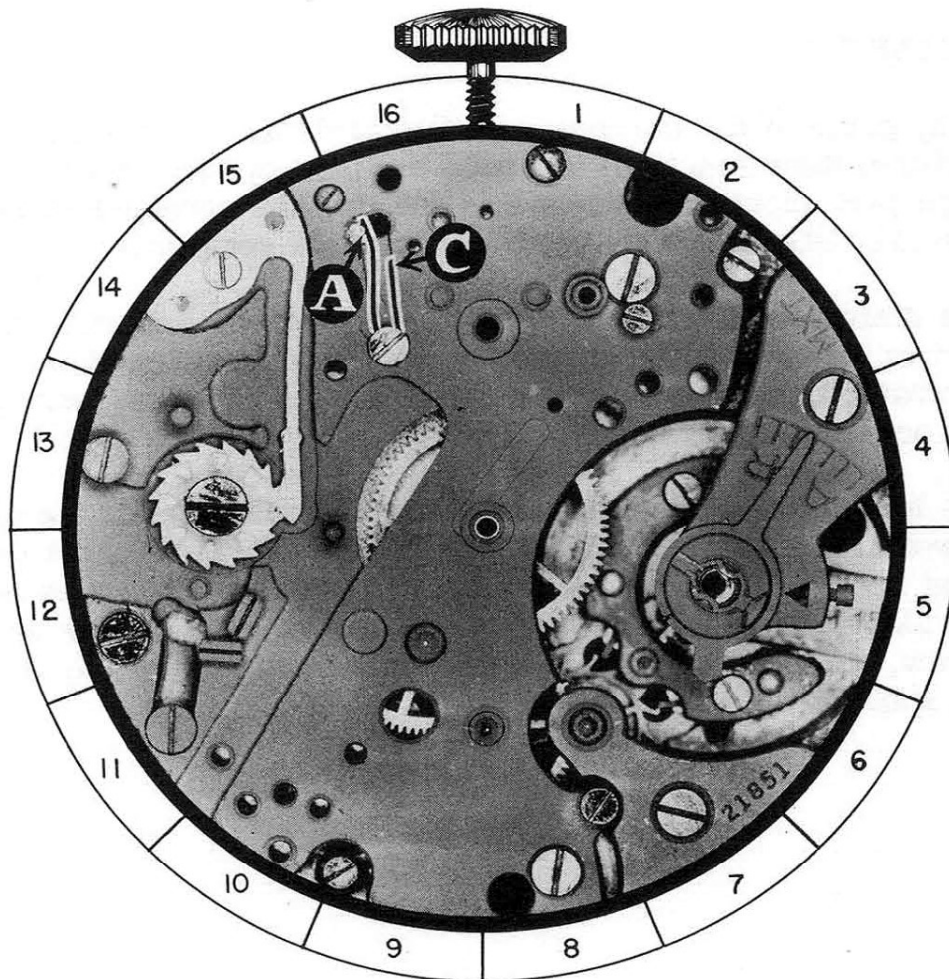

30-A

**A. DISASSEMBLY PROCEDURE OF TRIP PIN:**

This pin fits down in pivot hole in plate, and is simply lifted out of place.

**B. ASSEMBLY PROCEDURE OF TRIP PIN:**

Place pivot of trip pin down in pivot hole in plate with the end "A" of trip pin up.

**C. FUNCTION OF TRIP PIN:**

The function of this pin is to hold the flyback lever away from center of watch. This pin will release flyback lever only when chronograph push button for setting back to a zero is pushed.

**REFERENCE:** Flyback lever is Assembly 16.

**REMARKS:**

Many parts of the chronograph mechanism, that pivot or turn to perform their function, are held in place by shouldered screws. Each part should be checked to see that the shoulder of screw properly fits this part, so it will function correctly.

The diameter of the shoulder of a screw should permit the part to turn freely on shoulder, but any excess freedom should be avoided, as it may permit the part to shift under screw head and not function properly.

The length of the shoulder of a screw should permit the part to work freely under head of screw without binding, yet there must not be excessive movement of part between screw head and plate. Excessive movement of part, between plate and screw, can be corrected by placing screw in lathe and shortening shoulder of screw with graver.



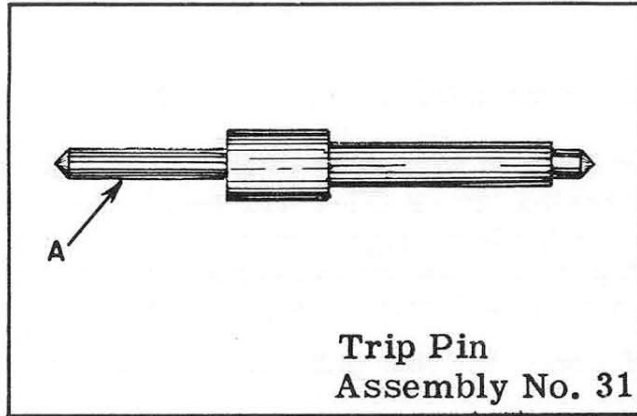

### OILING

Pivot of trip pin, that fits in plate, should be slightly moistened with oil.

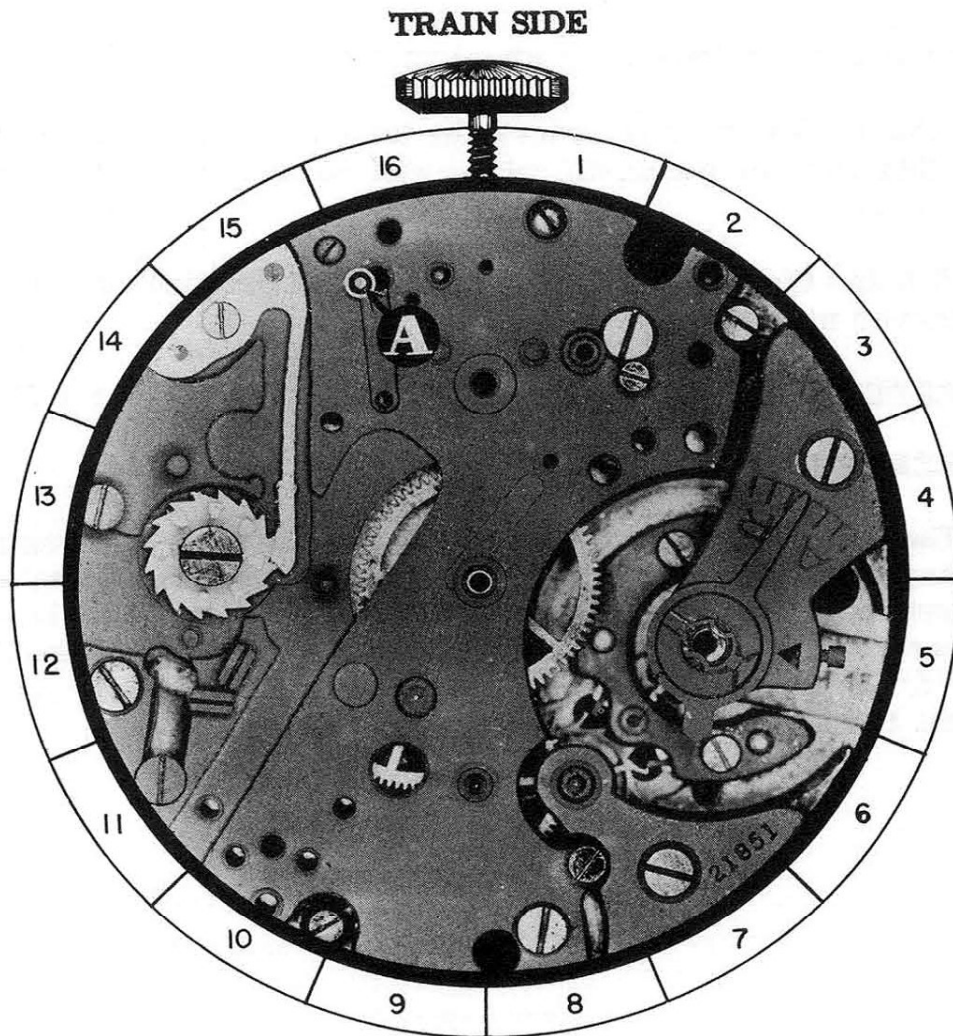

31-A

**A. DISASSEMBLY PROCEDURE OF CASTLE WHEEL PAWL:**

This pawl fits down in recess in plate and is held in place by beveled countersink screw BS-4 and steady pins in plate. After screw is removed, place finger over pawl and loosen pawl from the plate with a thin blade screwdriver. When pawl is free of steady pins, it may be lifted from movement.

(The shape of screw for this part is shown at bottom of page.)

**B. ASSEMBLY PROCEDURE OF CASTLE WHEEL PAWL:**

Place pawl in recess in plate with end "A" between two ratchet teeth of castle wheel and holes in pawl over steady pins in plate. Press pawl down in position, and replace beveled countersink screw BS-4.

**C. FUNCTION OF CASTLE WHEEL PAWL:**

The functions of the castle wheel pawl are as follows:

1. This pawl correctly spaces the turning of the castle wheel. This assures the castle wheel will not set at an incorrect position.
2. It holds the castle wheel in the correct position until it is moved manually.

**REFERENCE:** Castle wheel ratchet teeth is Assembly 33B.

**REMARKS:**

The end "A" of castle wheel pawl must be highly polished. Any roughness or pits of rust at this location may cause the pawl not to function properly. If it is necessary to polish this part, care should be taken not to change the shape of the end "A" of pawl. It must be of correct shape to properly space the turning of the castle wheel.

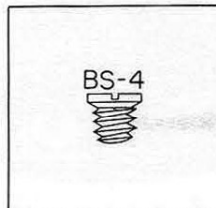

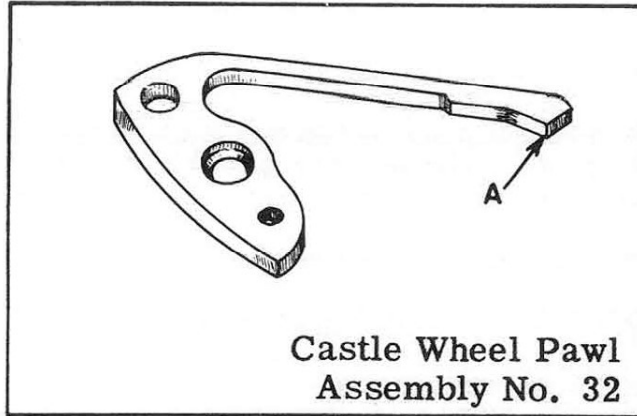

### OILING

The castle wheel pawl should not be oiled.

### TRAIN SIDE

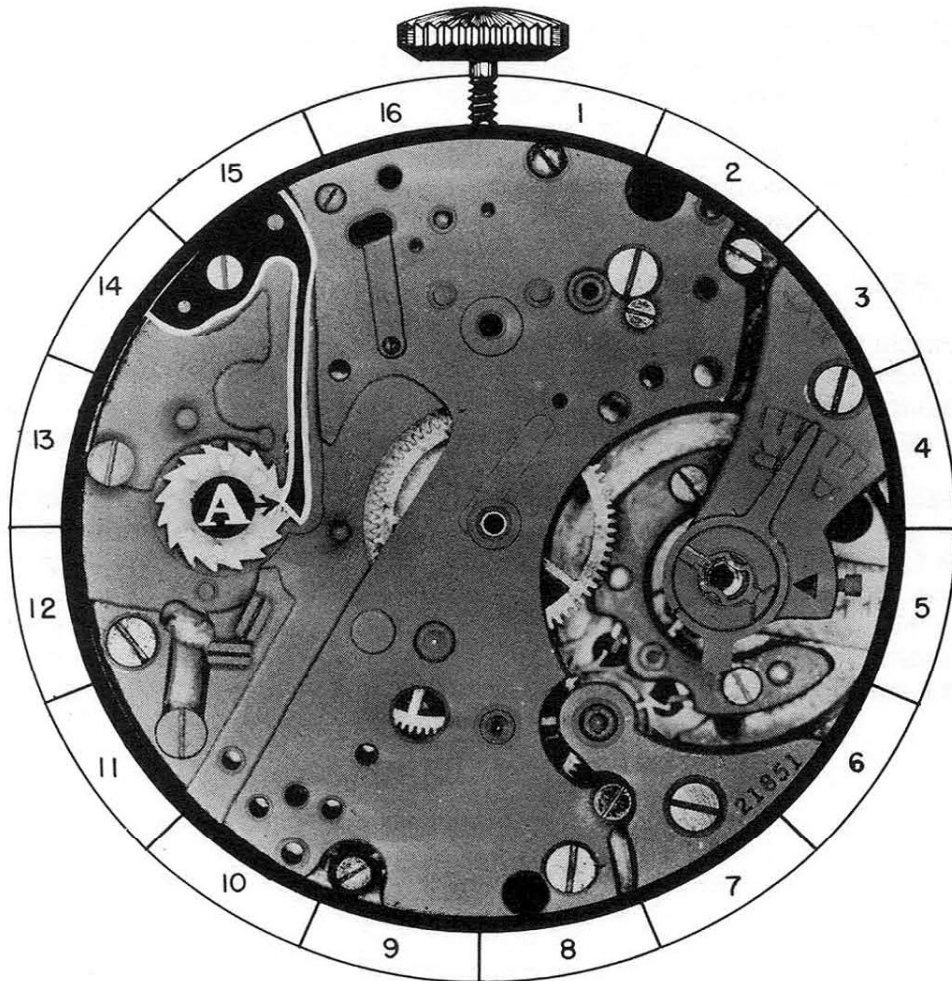

32-A

PART NO. 33

**A. DISASSEMBLY PROCEDURE OF CASTLE WHEEL:**

The castle wheel is held in place by fillister head screw FS-9, and pivots on a hollow stud on the plate. After screw is removed, the wheel will be free on the plate, and may be lifted from the movement.

(The shape of screw for this part is shown at the bottom of the page.)

**B. ASSEMBLY PROCEDURE OF CASTLE WHEEL:**

Place wheel over hollow post in plate, as shown in photograph. Replace fillister head screw FS-9, that holds this wheel in place. Wheel should pivot freely under head of screw.

**C. FUNCTION OF CASTLE WHEEL:**

The functions of the castle wheel are as follows:

1. It disengages intermediary wheel from seconds wheel.
2. It disengages brake lever from seconds wheel.
3. It controls the engaging and disengaging of the hour brake lever.
4. It disengages flyback lever from seconds wheel and minute register wheel hearts.

**REFERENCE:** Intermediary wheel is Assembly 14.  
Seconds wheel is Assembly 25.  
Brake lever is Assembly 19.  
Hour register wheel is Assembly 8.  
Flyback lever is Assembly 16.  
Hour brake lever is Assembly 2.  
Minute register wheel is Assembly 27.

**REMARKS:**

The castle wheel performs its function by the columns "A" which are evenly spaced around the center of the wheel. As the castle wheel is turned, the column either forces a part to move out from the center of the castle wheel or permits it to move into the empty space between two columns.

For example, the intermediary wheel is disengaged from the seconds wheel by the columns of the castle wheel, forcing the end of chronograph pivoted detent from between the columns until the point of this lever rests on a column. To engage the intermediary wheel with the seconds wheel, the castle wheel is turned one space; this permits the end of chronograph pivoted detent to enter the empty space between the columns, which permits the two wheels to be engaged by the chronograph pivoted detent.

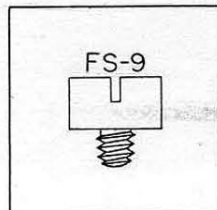

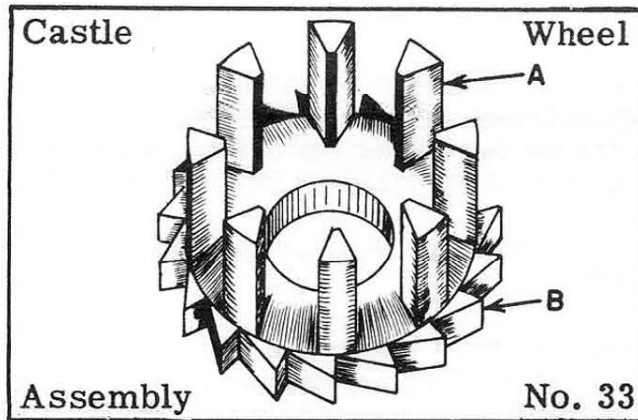

### OILING

These parts of castle wheel should be slightly moistened with oil:

1. The hollow post in plate on which castle wheel pivots
2. The columns "A" on castle wheel at the points that they contact the parts of this mechanism
3. The ratchet teeth "B" on castle wheel should be slightly moistened with oil.

### TRAIN SIDE

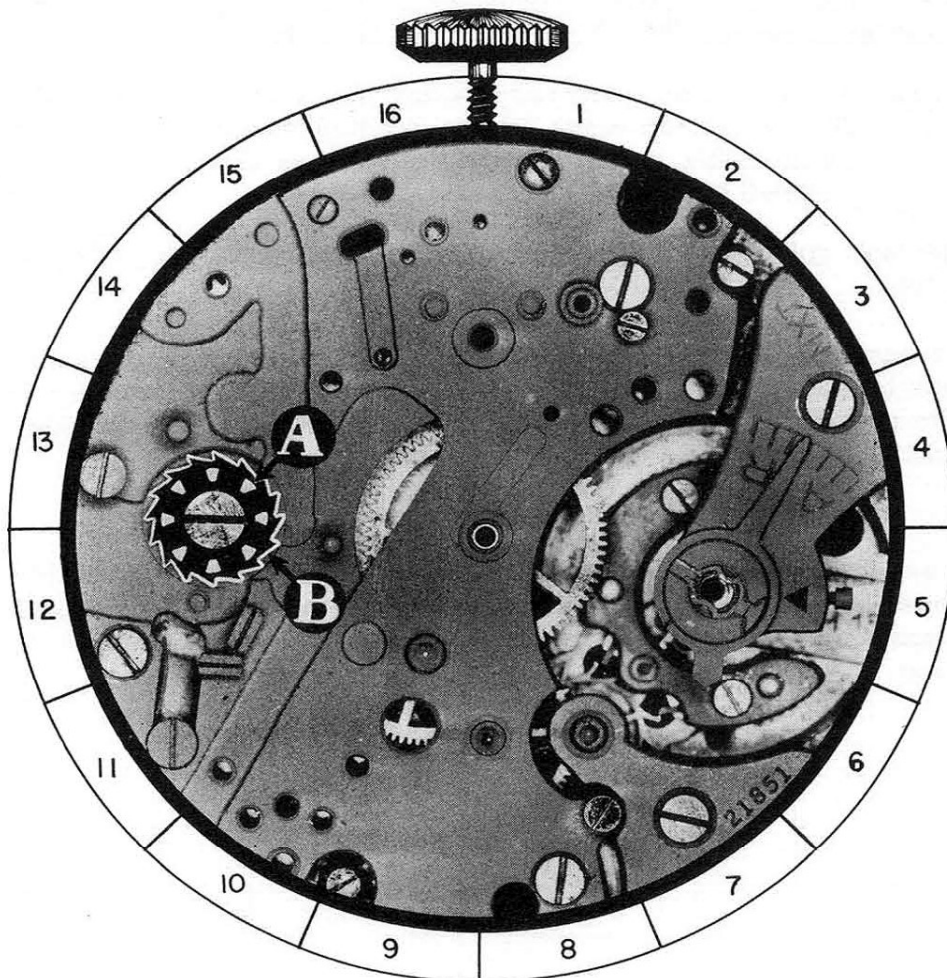

33-A

## PART NO. 34

The chronograph mechanism is now completely disassembled with the exception of this part. Completely disassemble the watch as you would an ordinary watch, and remove the tension spring for driving pinion and driving pinion from the main spring barrel by following the instructions below:

### A. DISASSEMBLY PROCEDURE OF DRIVING PINION TENSION SPRING AND DRIVING PINION:

The driving pinion spring is held to the barrel cap by fillister head screws FS-10 and FS-11. After these screws are removed, the spring and driving pinion can be lifted from barrel arbor. Tension spring may now be lifted from driving pinion.

(The shape of screws for this part is shown at bottom of page.)

### B. ASSEMBLY PROCEDURE OF DRIVING PINION TENSION SPRING AND DRIVING PINION:

Place tension spring on pinion, as shown in the isometric drawing with the highly polished parts "A" and "B" of spring, that hold pinion in position down. Now place this assembly on long pivot of barrel arbor with the pinion up, as shown in drawing at bottom of page. Now replace fillister head screws FS-10 and FS-11 to hold these parts in place.

**Caution:** Do not tighten these screws any more than is necessary. The barrel cap being thin necessitates caution, since the screw holes in this cap have very few threads in them and are easily stripped by excess tightening of screw.

### C. FUNCTION OF DRIVING PINION TENSION SPRING AND DRIVING PINION:

The function of the spring is to hold the driving pinion to barrel cap with enough tension to turn the driving pinion, when the chronograph mechanism is engaged. When the chronograph is disengaged, the driving pinion is held stationary while the barrel continues to turn.

#### NOTICE

Now assemble the watch in the ordinary manner with the exception of balance assembly, and place watch in movement holder with train side up. Now assemble the chronograph mechanism by following the instructions in the text.

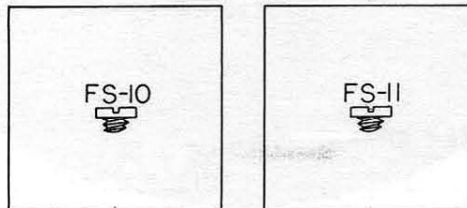

**Assembly No. 34**

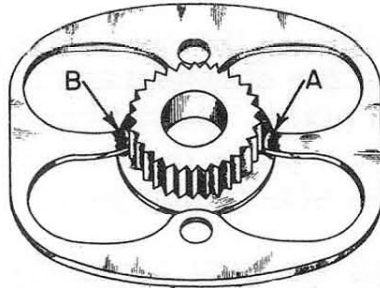

**Driving Pinion Tension Spring  
and Driving Pinion.**

**OILING**

The following parts should be oiled:

1. The part of driving pinion that contacts barrel cap.
2. The barrel arbor pivot on which driving pinion pivots.

Caution: Do not over oil these parts.

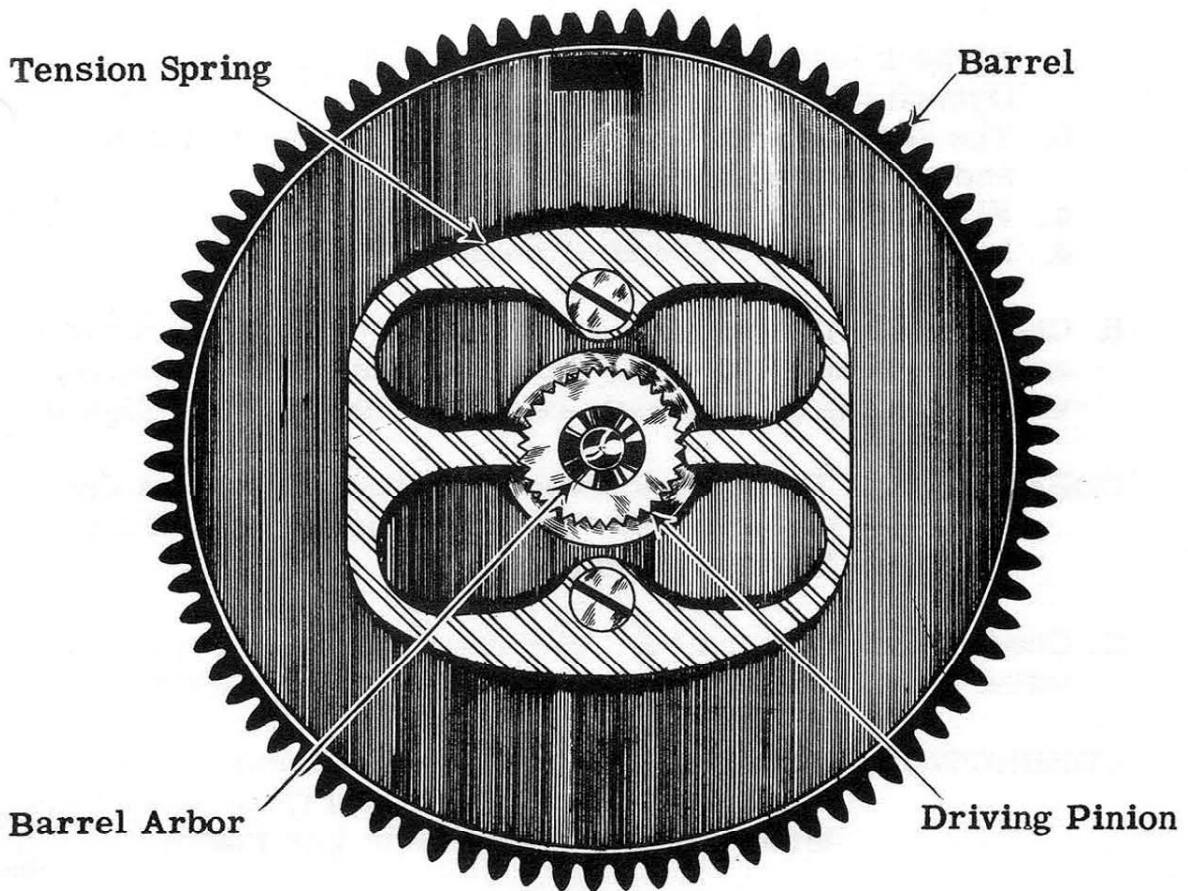

## FUNCTIONAL RESULTS

After completely assembling the chronograph with the exception of dial and hands, place the chronograph in the case with the chronograph buttons in place. Do not replace the bezel and back of case at this time. Now place the chronograph in front of you, pendant up and the train side facing you.

### 1. PUSH THE BUTTON AT THE LEFT OF THE PENDANT, RELEASE IT, AND CHECK THE FOLLOWING:

(Make sure that the castle wheel is in position, which permits the flyback lever to be moved toward the center of the watch.)

- A. Check to see that flyback lever has returned the seconds wheel and minute register wheel to a zero position.

**CORRECTION:** The following errors may prevent the seconds wheel and minute register wheel from returning to a zero position:

- a. Flyback lever spring not holding a proper tension on flyback lever.
- b. The seconds wheel or minute register wheel binding and not turning freely.
- c. Flyback lever binding and not turning freely.
- d. Intermittent lever binding on post.

- B. Check to see that the ends "A" and "B" of flyback lever are of correct length to hold the seconds wheel stationary while permitting the minute register wheel to turn slightly.

**CORRECTION:** The flyback lever being bent may cause the ends "A" or "B" of this lever to be of an incorrect length.

- C. Check to see that end "A" of minute register pawl is centered between two teeth on the minute register wheel.

**CORRECTION:** The following errors may prevent the end "A" of minute register pawl from being centered between two teeth on this wheel:

(Continued on next page)



**FUNCTIONAL RESULTS  
(CONTINUED)**

- a. Minute register pawl spring not holding proper tension on minute register pawl.
- b. Improper adjustment of eccentric stud ES-5. (See adjustment of eccentric studs.)
- c. The intermittent or the minute register wheel binding and not turning freely may result in the end "A" of minute register pawl not being centered between two teeth on the minute register wheel.

D. Check to see that intermittent wheel has moved away from the center of the watch, so the dart tooth cannot engage with the teeth on this wheel.

**CORRECTION:** Failure of intermittent wheel to move away from seconds wheel dart tooth may be caused by improper adjustment of eccentric stud ES-4. (See adjustment of eccentric studs.)

**2. PRESS THE BUTTON AT THE RIGHT OF THE PENDANT, RELEASE IT, AND CHECK THE FOLLOWING:**

A. Check depthing of intermediary wheel teeth with the seconds wheel teeth.

**CORRECTION:** The following errors may prevent correct depthing of these teeth:

- a. Chronograph pivoted detent and actuating detent lever spring not holding proper tension on chronograph pivoted detent.
- b. Chronograph pivoted detent not pivoting freely.
- c. Improper adjustment of adjusting stud AS-2. (See adjustment of eccentric studs.)

B. Check depthing of seconds wheel dart tooth with intermittent wheel teeth.

**CORRECTION:** The following errors may prevent the proper depthing of dart tooth with intermittent wheel teeth:

(Continued on next page)

**FUNCTIONAL RESULTS  
(CONTINUED)**

- a. Intermittent lever spring not holding proper tension on intermittent lever.
- b. Intermittent lever binding and not pivoting freely on post in plate.
- c. Improper adjustment of adjusting stud AS-3. (See adjustment of eccentric studs.)

**REMARKS:** If the depthing of the intermittent wheel teeth with the seconds wheel dart tooth is too deep, the dart tooth may move the minute register wheel two teeth each time the seconds wheel makes one revolution.

If the depthing is shallow, it may cause the minute register wheel to fail to move a full tooth each time the dart tooth makes one revolution.

**3. PUSH THE BUTTON AT THE RIGHT OF THE PENDANT, RELEASE IT, AND CHECK THE FOLLOWING:**

- A.** Check to see that trip pin is holding the flyback lever away from the center of the watch.

**CORRECTION:** The following errors may prevent the trip pin from holding the flyback lever away from the center of the watch:

- a. Trip pin spring not holding enough tension on trip pin.
- b. Trip pin spring not being in the proper position.

- B.** Check to see that brake lever is contacting the seconds wheel.

**CORRECTION:** The following errors may prevent the brake lever from contacting the seconds wheel:

- a. The blade of brake lever not having proper tension for brake lever to function properly.
- b. Brake lever binding and not turning freely.

(Continued on next page)

**FUNCTIONAL RESULTS  
(CONTINUED)**

4. Turn movement over, dial side up, with pendant away from you.

**PUSH THE BUTTON AT THE RIGHT OF THE PENDANT, HOLD IN THIS POSITION, AND CHECK THE FOLLOWING:**

- A. Check to see that hour flyback lever has returned the hour register wheel to a zero position.

**CORRECTION:** The following errors may prevent the hour flyback lever from returning the hour register wheel to a zero position:

- a. Hour flyback lever binding and not turning freely.
- b. Hour register wheel binding and not turning freely.
- c. The driving pinion binding on the barrel arbor.

5. **RELEASE THE BUTTON AND CHECK THE FOLLOWING:**

- A. Check to see that the hour flyback lever has returned to its original position.

**CORRECTION:** The following errors may prevent the hour flyback lever from returning to its original position:

- a. Flyback lever binding and not turning freely.
- b. Flyback lever spring not holding proper tension on flyback lever.

- B. Check to see that hour brake lever is contacting the hour register wheel.

**CORRECTION:** The following errors may prevent the hour brake lever from contacting hour register wheel:

- a. Hour brake lever binding under head of screw and not turning freely.
- b. Hour brake lever spring not holding proper tension on hour brake lever.
- c. Improper adjustment of eccentric stud ES-6. (See adjustment of eccentric studs.)

(Continued on next page)

**FUNCTIONAL RESULTS  
(CONTINUED)**

**6. PUSH THE BUTTON AT THE LEFT OF THE PENDANT, RELEASE IT, AND CHECK THE FOLLOWING:**

- A. Check to see that hour brake lever is disengaged from hour register wheel.

**CORRECTION:** Improperly adjusted eccentric stud on the connecting lever may prevent the hour brake lever from disengaging from the hour register wheel.

**7. PUSH THE BUTTON AT THE RIGHT OF THE PENDANT, HOLD IN THIS POSITION, AND CHECK THE FOLLOWING:**

- A. Check to see that hour brake lever prevents the hour flyback lever from contacting the hour register wheel.

**CORRECTION:** Improperly adjusted eccentric stud on the connecting lever may permit the hour flyback lever to contact the heart on hour register wheel.

**8. Remove the movement from case, replace dial and hands, and replace movement in case.**

**PUSH THE BUTTON AT THE LEFT OF THE PENDANT, RELEASE IT, AND CHECK THE FOLLOWING:**

- A. Check to see that the seconds hand does not jump forward more than  $1/5$  of a second at the instant the chronograph is engaged.

**CORRECTION:** Excess separation of seconds wheel and intermediary wheel when chronograph is disengaged may cause the seconds hand to move forward more than  $1/5$  of a second at the instant chronograph is engaged.

- B. Check to see that seconds hand moves forward in a steady even manner with no irregular jumping or jerking.

**CORRECTION:** The following error may cause the seconds hand to move forward in an irregular manner:

(Continued on next page)

**FUNCTIONAL RESULTS  
(CONTINUED)**

- a. Seconds wheel tension spring not holding enough tension on seconds wheel.
  
- C. Check to see that minute register hand completes the registration of one minute when the seconds hand passes 60 on the dial.

**CORRECTION:** The following errors may cause the minute register hand to register the passage of one minute either before or after the seconds hand passes 60 on the dial:

- a. The seconds hand not being set correctly.
  - b. Dart tooth incorrectly set on seconds wheel.
  - c. Minute register pawl not being correctly adjusted to minute register wheel.
- D. Let the chronograph run for a period of time and check to see that hour register hand correctly registers the passage of hours.

**CORRECTION:** The following errors may prevent the hour register hand from properly registering the passage of hours:

- a. Hour register wheel not turning freely.
  - b. Tension spring for driving pinion not holding proper tension on driving pinion.
9. **PUSH THE BUTTON AT THE RIGHT OF THE PENDANT, HOLD IN THIS POSITION, AND CHECK THE FOLLOWING:**
- A. Check to see that seconds hand, minute register hand and hour register hand have all returned to a zero position.

**CORRECTION:** Hands being loose or incorrectly placed on their respective posts may cause the hands not to return to a zero position.

## THE TACHOMETER

- A. The tachometer is used to indicate the speed of an object in miles per hour. A tachometer can only indicate the average speed of an object traveling over a course of a measured mile.

### METHOD OF USING TACHOMETER

1. Start chronograph sweep second hand at the exact moment the object starts to travel the measured distance of one mile.
2. When the object has traveled the course of one mile, stop the chronograph sweep second hand. The point on the tachometer scale where the sweep second hand stopped will indicate the average speed of the object in miles per hour.

### SECOND HAND

- B. The second hand indicates the passing of seconds and should move one space each second. One complete revolution of hand denotes passage of one minute. This hand is independent of chronograph mechanism and continues to register the seconds as long as watch is running.

### SPLIT SECOND SCALE

- C. This scale is divided into 300 divisions, each indicating  $1/5$  of a second. Every fifth division is marked with extra long lines denoting one second.

The main purpose of this scale is to measure a fraction of a second accurately.

### MINUTE REGISTER

- D. The minute register hand indicates on the dial the number of minutes that have elapsed since the beginning of the registration of the sweep second hand. One complete revolution of the minute register hand indicates the passage of 30 minutes; two revolutions, one hour.

### HOUR REGISTER

- E. The hour register hand indicates on the dial the number of hour that have elapsed since the beginning of the registration of the sweep second hand. Each division on the scale denotes  $1/2$  hour. Each number on scale denotes one hour. One complete revolution of hour register hand indicates 12 hours have elapsed. This hand will register the hours as long as the chronograph mechanism is in operation.

# THE CHRONOGRAPH DIAL

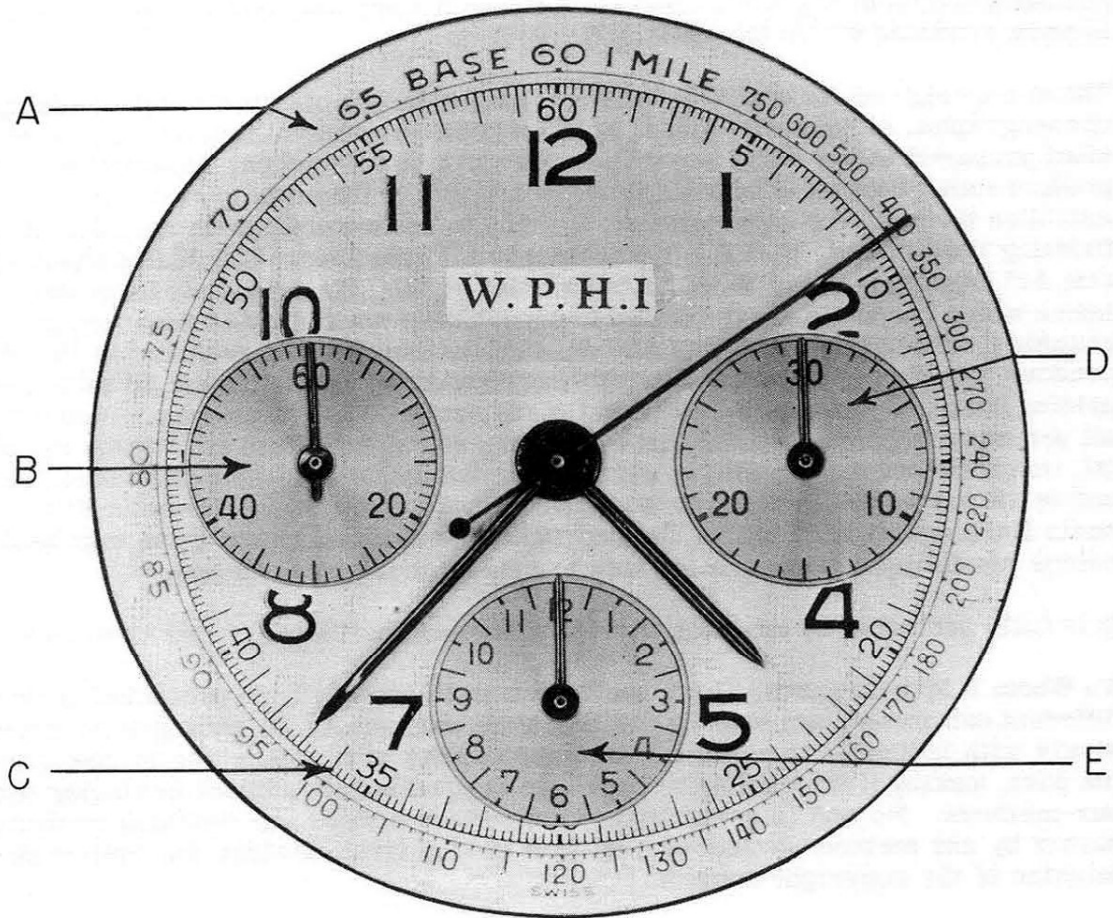

## SETTING THE HANDS CORRECTLY ON A CHRONOGRAPH

After the chronograph is completely assembled and in working condition, replace the hour hand, minute hand, and second hand as you would on a regular watch. At this point, do not replace the sweep second hand, the minute register hand or the hour register hand. Now push the button and bring the flyback lever in toward the center of the watch. When the flyback lever is held in toward the center of the watch, place the sweep second hand at 60 on split second scale "C". Place the minute register hand at 30 on minute register scale "D". Place the hour register hand at 12 on the hour register scale "E". After these hands are replaced, start chronograph mechanism with sweep second hand turning. Let chronograph mechanism run for at least 40 minutes; now push the button to bring the flyback lever in toward the center of the watch again and check to see that the sweep second hand, the minute register hand, and the hour register hand go back to their original position.