

WORLD'S ONLY  
FULLY ILLUSTRATED  
**CHRONOGRAPH WATCH COURSE**  
VOLUME 15

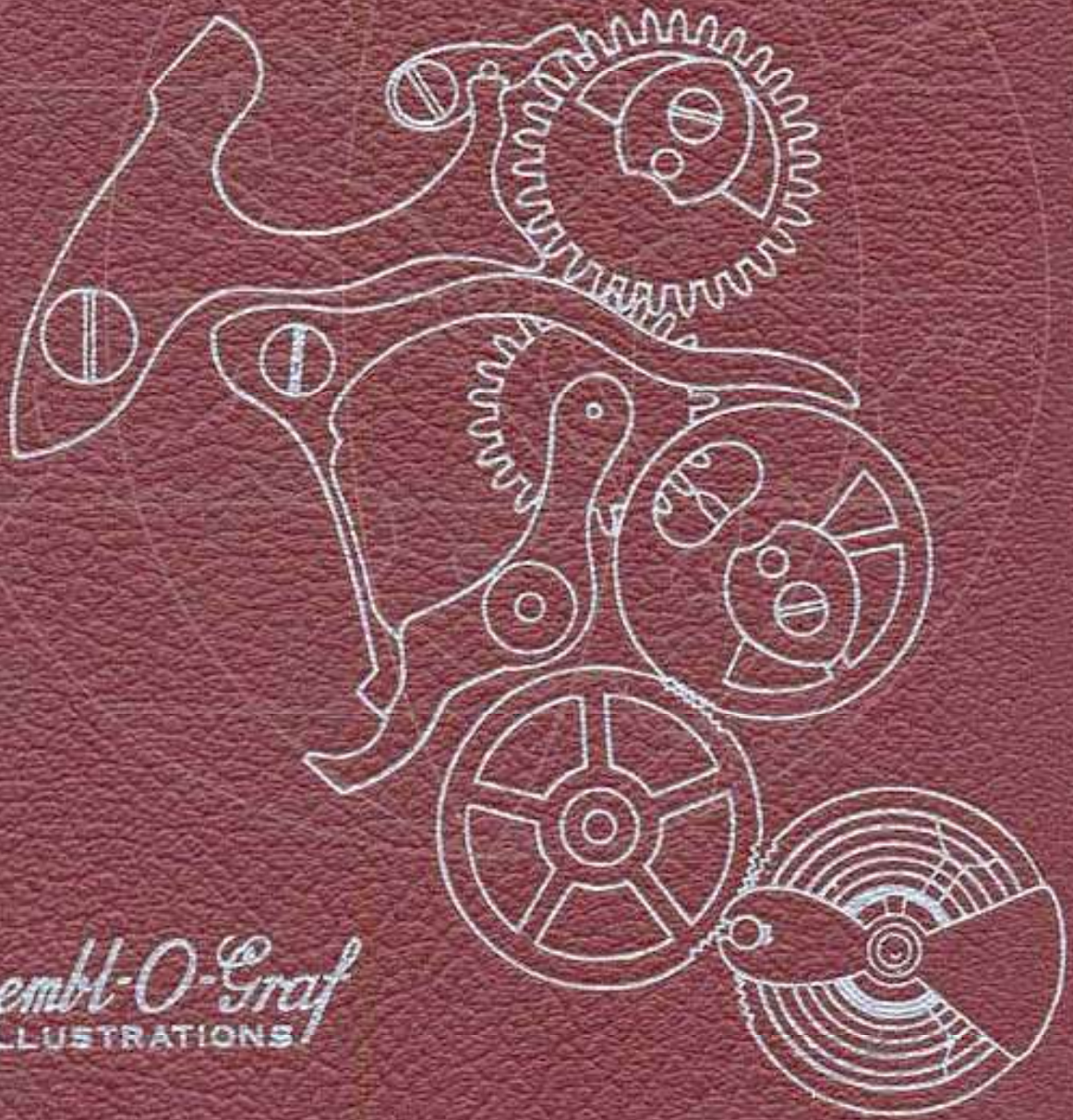

*Esseml-O-Graf*  
ILLUSTRATIONS

# IDENTIFICATION OF CHRONOGRAPH

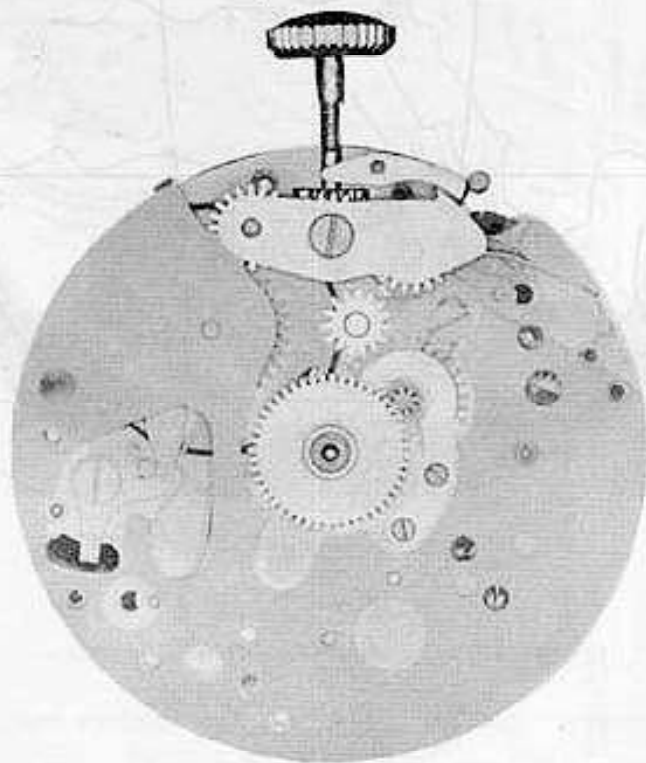

13L

PIERCE



CAL. 134



# ESEMBL-O-GRAF

THE WORLD'S FIRST FULLY  
ILLUSTRATED TEXT BOOK  
ON  
CHRONOGRAPH REPAIRING  
AND ADJUSTING

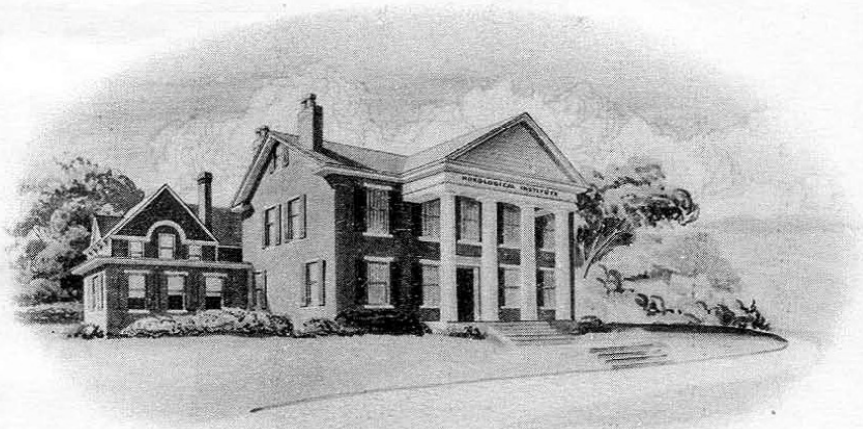

BY  
**William O. Smith, Sr.**  
PRESIDENT AND TECHNICAL DIRECTOR  
AND  
**William O. Smith, Jr.**  
CHIEF ENGINEER, RESEARCH LABORATORIES

WESTERN PENNSYLVANIA HOROLOGICAL INSTITUTE, INC.  
PITTSBURGH, PENNSYLVANIA

**INSTRUCTIONS**  
For use of book

**DISASSEMBLY OF THE CHRONOGRAPH MECHANISM:**

1. Study the isometric drawing at top of page 1-A. The isometric drawing was made for the following purposes:
  - A. It helps to identify the part to be removed.
  - B. This drawing aids in pointing out certain locations on the part that are mentioned in the oiling procedure.
  - C. The text refers to certain points on the part. These points are shown in the isometric drawing. This should aid you in finding the exact location on the part that is described in the text.
  - D. It helps you to know the shape of the part in case a new part has to be made.
2. At the bottom of the page 1-A is a photograph of a chronograph. In this photograph is the same part painted in black. The part is in its exact location that this part occupies in the watch. Find this location in the watch.
3. Read the disassembly procedure and the hazards in disassembly on page 1 in this book.
4. Remove this part in the same procedure as described in the text.
5. A very important item in disassembling a chronograph is keeping the screws in order, much time will be lost in putting the chronograph together if screws are mixed up. This means you have to hunt for each screw, sometimes trying three or four screws before finding the correct one. It cannot be stressed too strongly that care should be taken so that screws are not mixed up. The system that we advise for beginners, is to replace each individual screw after each part is removed. This naturally eliminates the hazard of mixing up the screws and will save you much time in the end. Do this at least until you become so thoroughly familiar with the chronograph that you no longer feel it is necessary.
6. Continue to follow this procedure throughout the book and disassemble each part until the last part of the chronograph is removed.

**ASSEMBLY OF THE CHRONOGRAPH MECHANISM:**

7. When you are ready to assemble the chronograph mechanism, study the isometric drawing on the last part in this book. This drawing should aid you in identifying the part to be assembled.
8. At the bottom of this page is a photograph of a chronograph. In this photograph is the same part painted in black. The part is in its exact location that this part occupies in the watch.
9. Read the assembly procedure and the hazards in assembling for the last part in this book. (Continued on next page)

## INSTRUCTIONS (Continued)

10. Replace the part in its exact location as shown in photograph, using the procedure as described in the text.

11. After you find the correct location for this part in the watch, read the oiling procedure for this part. The oiling procedure for this part is located underneath the isometric drawing. It is best to read the oiling procedure before you put each part in place as there are certain parts that must be oiled immediately as it may prove difficult to oil them later.

12. Replace the screw that holds this part in place. Of course, the screws should be kept in order as we advised above, but if the screws are not in order or the watch was received with screws mixed up, you will find a screw drawn for each part that requires a screw at the bottom of the text page.

13. After replacing this part, replace the next part, etc., until the last part is replaced, which will be part No. 1. Each part should be replaced using the same procedure as described in the text.

(Naturally, the assembly of the chronograph is exactly the reverse of the disassembly)

14. After disassembling and assembling the chronograph mechanism, start on page 1 and read the function of this part. After reading the function of this part, continue to read the function of each part throughout the book. Study each part, one at a time. This text should help you to understand more fully the purpose of each part in the chronograph mechanism.

15. Now put movement in its case with dial on, then replace hands.

16. Study the text on functional results in this book, and check the chronograph mechanism as described in this text.

### NOMENCLATURE OF PART FOR CHRONOGRAPH MECHANISM













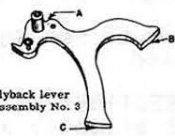
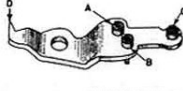
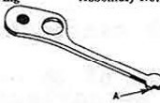

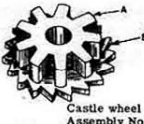

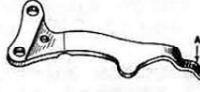
17. After you have become familiar with the chronograph mechanism, you can disassemble and assemble the chronograph by using the nomenclature of parts as a guide. This makes it possible for you to use a procedure without going through each page in the book.

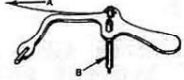
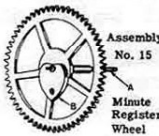
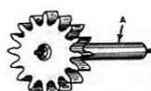
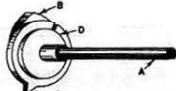
#### 18. ADJUSTMENT OF ECCENTRIC STUDS:

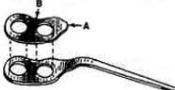
Read the text on adjustment of eccentric studs, this text should be read in reference to the eccentric stud picture. Now adjust each eccentric stud one at a time in the watch, as described in the text. Use the picture to show you the position of these studs.

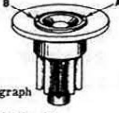
19. On each page in this book the part number and the page number are the same. This makes it convenient for the reader and eliminates any confusion.

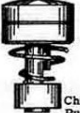
# NOMENCLATURE OF PARTS FOR CHRONOGRAPH MECHANISM

 <p>Flyback lever spring Assembly No. 1</p>	 <p>Connecting lever spring Assembly No. 2</p>	 <p>Flyback lever Assembly No. 3</p>
 <p>Connecting lever Assembly No. 4</p>	 <p>Push piece for setting back to zero spring Assembly No. 5</p>	 <p>Push piece for setting back to zero Assembly No. 6</p>
 <p>Castle wheel pawl Assembly No. 7</p>	 <p>Castle wheel Assembly No. 8</p>	 <p>Actuating push piece spring Assembly No. 9</p>
 <p>Actuating push piece Assembly No. 10</p>	 <p>Engaging spring Assembly No. 11</p>	 <p>Intermediary wheel tension spring Assembly No. 12</p>
 <p>Assembly bridge Assembly No. 13</p>	 <p>Minute register pawl Assembly No. 14</p>	 <p>Assembly No. 15 Minute Register Wheel</p>
 <p>Intermediary wheel Assembly No. 16</p>	 <p>Chronograph staff Assembly No. 17</p>	 <p>Lifting spring Assembly No. 18</p>
 <p>Stop spring Assembly No. 19</p>	 <p>End shake spring Assembly No. 20</p>	 <p>Chronograph pinion Assembly No. 21</p>
 <p>Sweep Second Hand</p>	 <p>Minute Register Hand</p>	 <p>Chronograph Push Button</p>
 <p>Chronograph Push Button</p>		

## ADJUSTING SCREWS

Listed below are a number of adjustments controlled by the adjustment screws.

1. Place the chronograph in position with the chronograph mechanism disengaged as shown in photograph.

- A. Check to see that stop spring is holding proper tension on chronograph pinion.

**CORRECTION:** To increase tension of stop spring, loosen adjusting screw AJ-7 slightly and tighten adjusting screw AJ-6. Naturally, to decrease the tension of spring you would reverse the procedure. Explanation of proper tension of stop spring on chronograph pinion is explained under remarks on page 19.

- B. Check to see that chronograph pinion has proper end shake.

**CORRECTION:** The proper end shake of chronograph pinion is set by adjusting screw AJ-8. Explanation of correct end shake is explained under remarks on page 20.

- C. Check to see there is clearance between engaging spring and chronograph staff. This clearance is controlled by adjusting screw AJ-9. The proper clearance between engaging spring and chronograph staff is explained, under remarks on page 11.

2. Now push the actuating push piece to turn castle wheel so the chronograph mechanism is engaged and check the following.

- A. Check to see that adjusting screw AJ-3 contacts the intermediary wheel tension spring at highest point "B" on hump of spring.

**CORRECTION:** Loosen adjusting screw AJ-1 and place spring so adjusting screw AJ-3 contacts spring at highest point on hump, then tighten screw AJ-1 to hold it in place.

- B. Check to see that adjusting screw AJ-4 contacts lifting spring at highest point on hump of spring.

**CORRECTION:** Loosen adjusting screw AJ-2 and place spring so adjusting screw AJ-4 contacts spring at highest point on hump, then tighten screw AJ-2 to hold spring in place.

- C. Check to see that intermediary wheel tension spring is disengaged from intermediary wheel.

**CORRECTION:** The clearance between intermediary wheel tension spring and the intermediary wheel is set by the adjusting screw AJ-3. The proper clearance of these parts is explained under remarks on page 12.

- D. Check the clearance between end of lifting spring and chronograph staff.

**CORRECTION:** The clearance between lifting spring and chronograph staff is controlled by adjusting screw AJ-4.

The proper clearance between lifting spring and chronograph staff is explained under remarks on page 18.

- E. Check to see that the chronograph staff is properly engaged with chronograph pinion.

**CORRECTION:** Adjustment screw AJ-5 controls the proper engagement of chronograph staff with chronograph pinion.

Explanation of correct engagement of chronograph staff with chronograph pinion is explained under remarks on page 4.



# ADJUSTMENT OF SCREWS

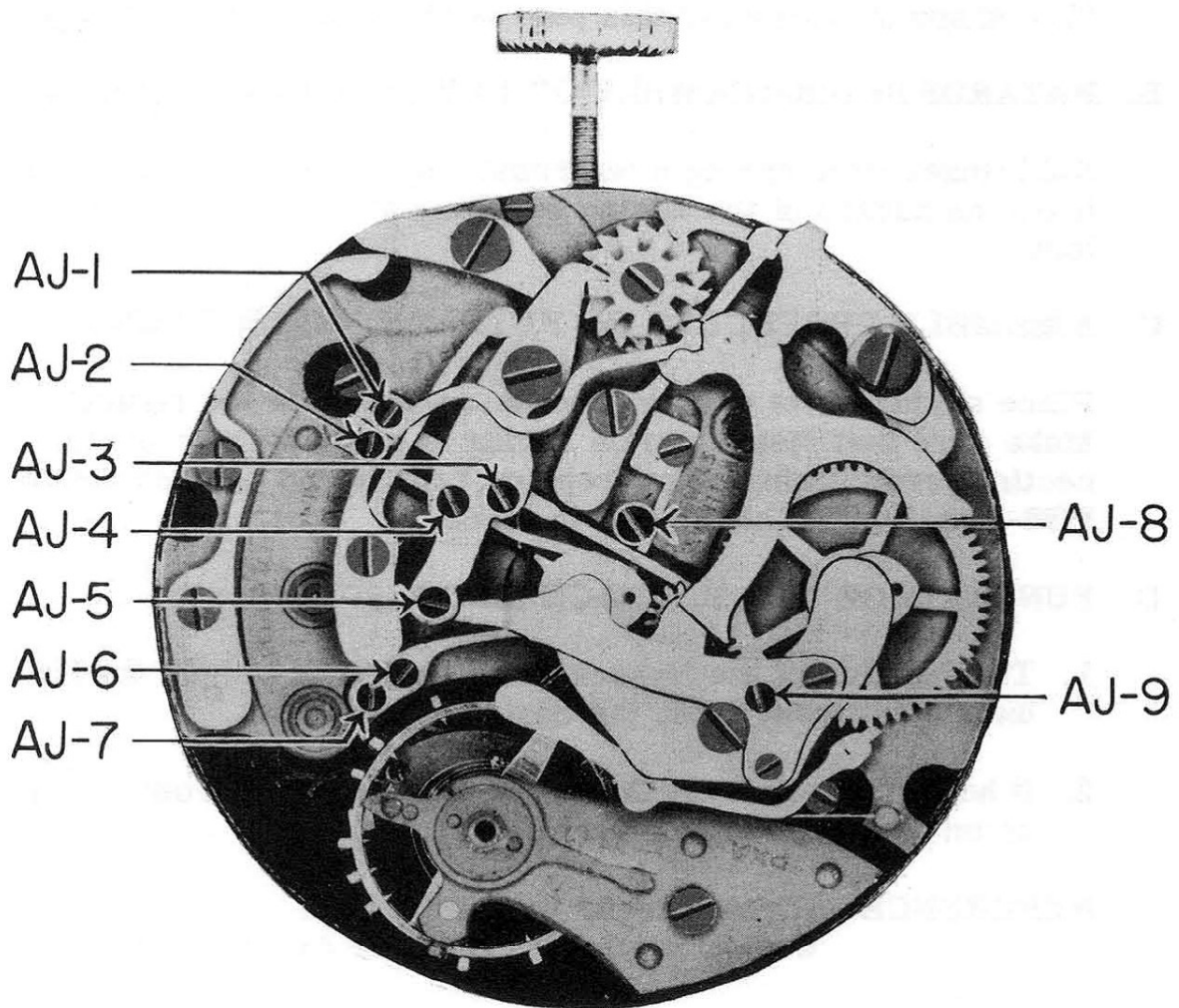

## CAUTION

When disassembling the chronograph, do not turn adjusting screws AJ-3, AJ-4 and AJ-5. These screws are used for adjusting purposes only and in turning them, you may lose the desired adjustment on these parts.

## PART NO. 1

### A. DISASSEMBLY PROCEDURE OF FLYBACK LEVER SPRING:

This spring is held in place by a body bound beveled screw BBS-1. When this screw is removed, spring can be lifted out of place.

(The shape of screw for this part is shown at bottom of page)

### B. HAZARDS IN DISASSEMBLY OF FLYBACK LEVER SPRING:

Hold finger over spring when removing screw, this will eliminate the hazard of the spring snapping away and becoming lost.

### C. ASSEMBLY PROCEDURE OF FLYBACK LEVER SPRING:

Place spring in its proper position as shown in the photograph. Make sure that steady pin on spring is entering hole in connecting lever spring. Now replace body bound beveled screw BBS-1 that holds this spring in place.

### D. FUNCTION OF THE FLYBACK LEVER SPRING:

1. The function of the flyback lever spring is to hold the flyback lever away from the center of the watch.
2. It holds flyback lever down on post keeping it from riding up on post and coming out of place.

**REFERENCE:** Flyback lever is Assembly 3.  
Connecting lever spring is Assembly 2.

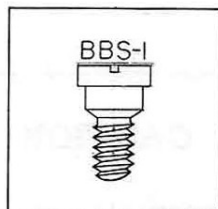

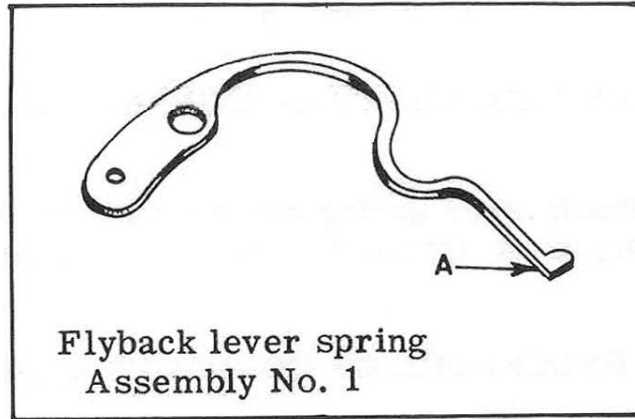

### OILING

End "A" on flyback lever spring should be slightly moistened with oil at point it contacts flyback lever.

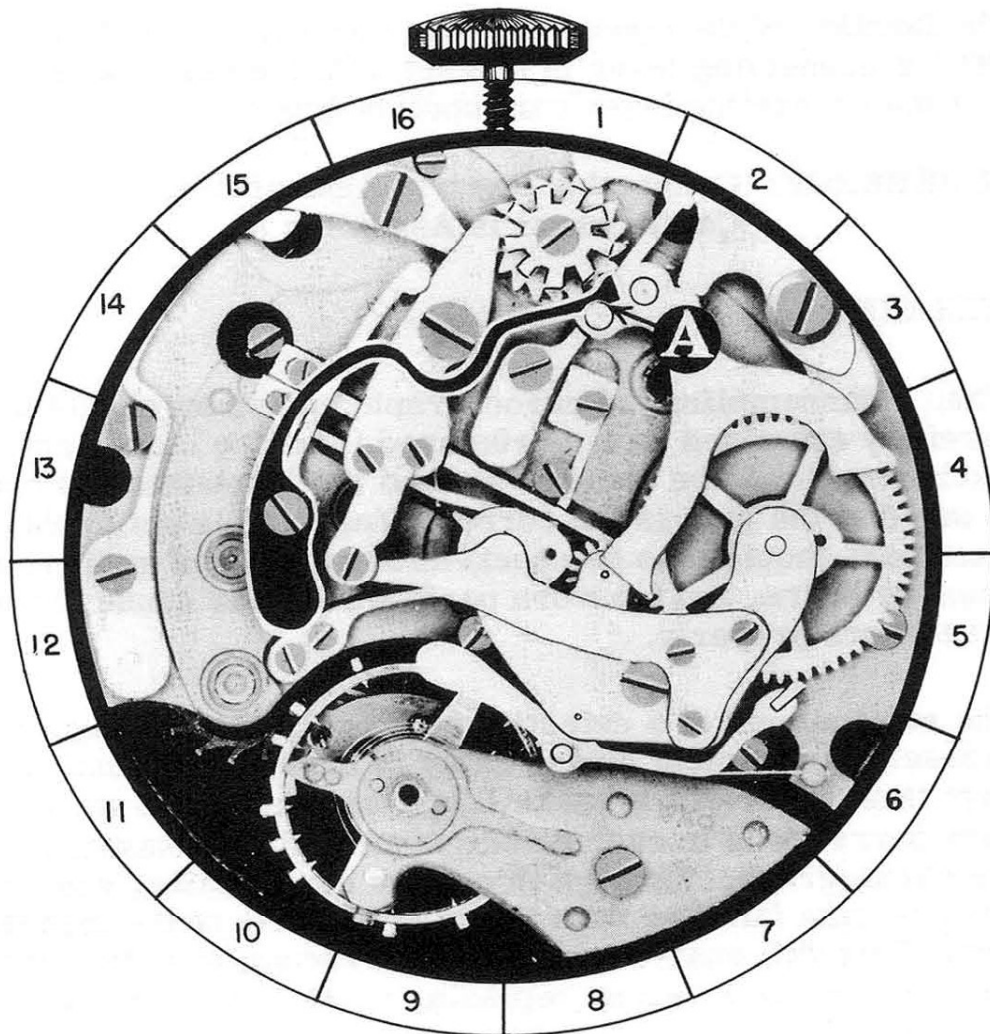

1-A

## PART NO. 2

### A. DISASSEMBLY PROCEDURE OF CONNECTING LEVER SPRING:

After the flyback lever spring has been lifted out of place, the connecting lever spring will be free on plate and can be removed.

### B. ASSEMBLY PROCEDURE OF CONNECTING LEVER SPRING:

Place spring in its proper position on plate as shown in photograph. Make sure that steady pin on spring is entering hole in plate. The screw for this part cannot be replaced until after the next part is put in place.

### C. FUNCTION OF CONNECTING LEVER SPRING:

The function of the connecting lever spring is to hold end 'D' of connecting lever in contact with the castle wheel so that the connecting lever can function properly.

**REFERENCE:** Connecting lever is Assembly 4.  
Castle wheel is Assembly 8.

### REMARKS:

When disassembling the chronograph, each part should be carefully examined as it is removed from the movement. Each part should be checked against the isometric drawings to see that the part is the correct shape and is not broken. Each part should also be checked for any pits of rust, roughness, or burrs, and for worn parts which may cause the part not to work properly.

The replacement of a defective part in the chronograph may necessitate complete disassembly of the chronograph. It will save time in the end to make this examination and the necessary corrections to each defective part while disassembling the chronograph. Through this close examination, you will soon become familiar with the various parts of the mechanism. This will enable you to quickly recognize a defective part and repair it before replacing in the chronograph.

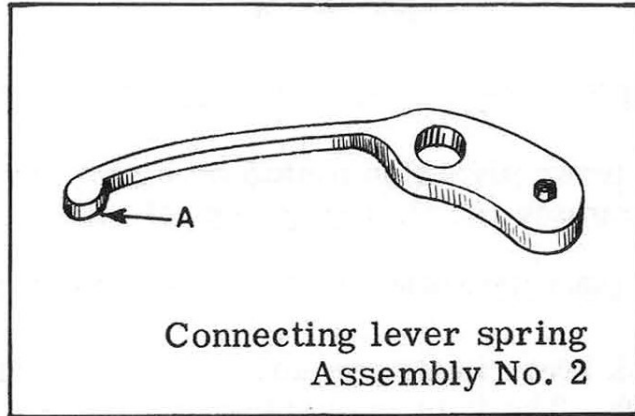

### OILING

End "A" of connecting lever spring should be slightly moistened with oil at point it contacts connecting lever.

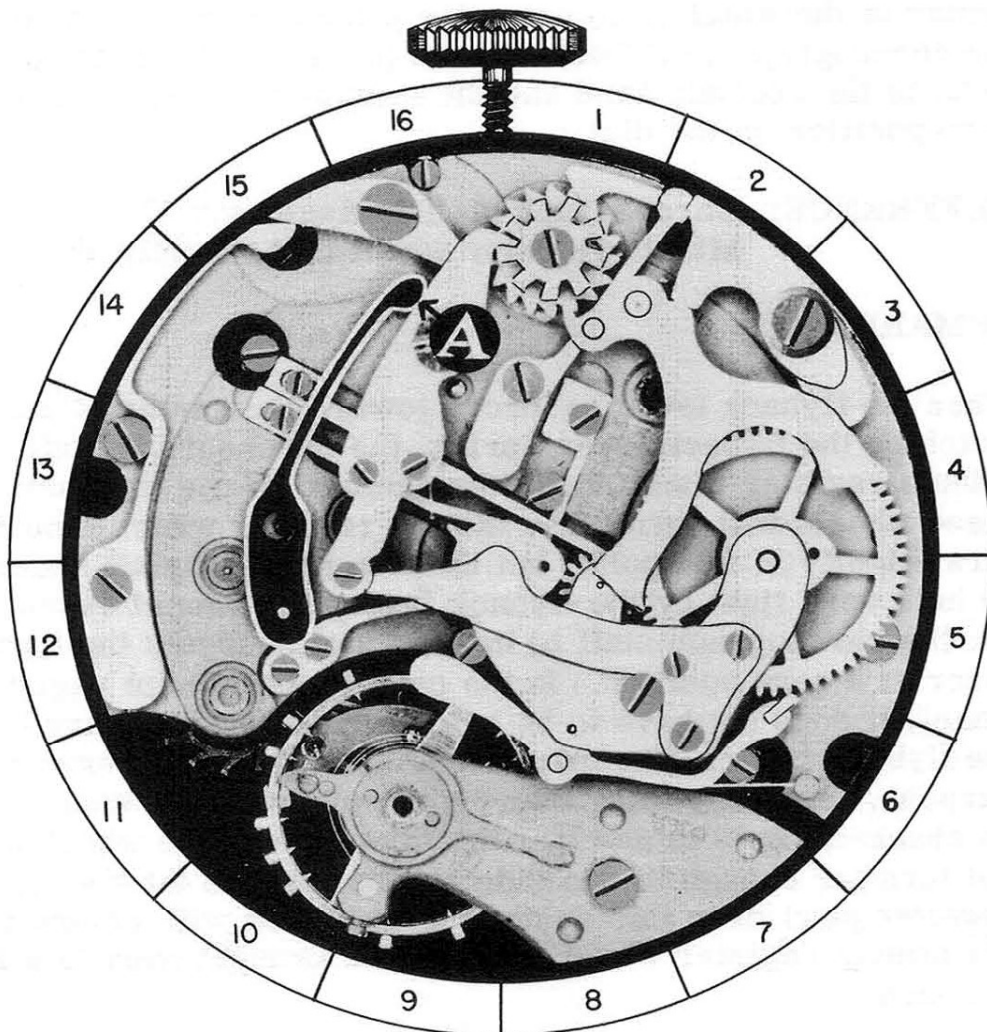

2-A

## PART NO. 3

### A. DISASSEMBLY PROCEDURE OF FLYBACK LEVER:

The flyback lever pivots on a stud on plate. To remove flyback lever, simply lift it straight up off stud.

### B. ASSEMBLY PROCEDURE OF FLYBACK LEVER:

Place flyback lever in its proper position on plate as shown in photograph. The hole in bushing in flyback lever must fit over the stud on plate as the flyback lever pivots on this stud. After replacing flyback lever, check flyback lever to see that it pivots freely on stud.

### C. FUNCTION OF FLYBACK LEVER:

The function of the flyback lever when pushed in towards the center of the watch is to bring the minute register wheel and the chronograph staff back to zero position. This, of course, returns the seconds hand and the minute register hand to a zero position on the dial.

**REFERENCE:** Chronograph staff is Assembly 17.  
Minute register wheel is Assembly 15.

### REMARKS:

When the flyback lever is forced toward the center of the watch by the flyback lever spring, the chronograph staff and minute register wheel should be checked to see if either of these wheels will turn. The minute register wheel should turn slightly at this point, but the chronograph staff should be held very tight by the flyback lever. It is most essential for the chronograph staff to be held stationary by the flyback lever at a zero position. In the case of the minute register wheel, it does not have to be held absolutely stationary by the flyback lever. The minute register pawl will serve this purpose. The only thing that the minute register wheel should be checked for is to see that the minute register wheel will not turn far enough to one side or the other to let the minute register pawl drop into another tooth. This will assure that the minute register wheel will also be brought back to a zero position.

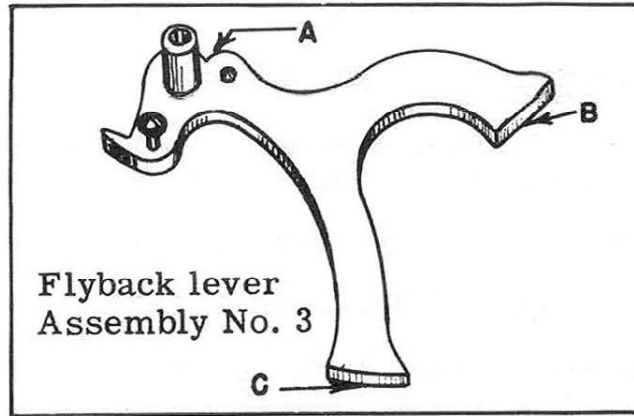

### OILING

- These points on flyback lever should be slightly moistened with oil:
1. The stud that flyback lever pivots on.
  2. Point "A" on flyback lever that contacts push piece for setting back to zero.

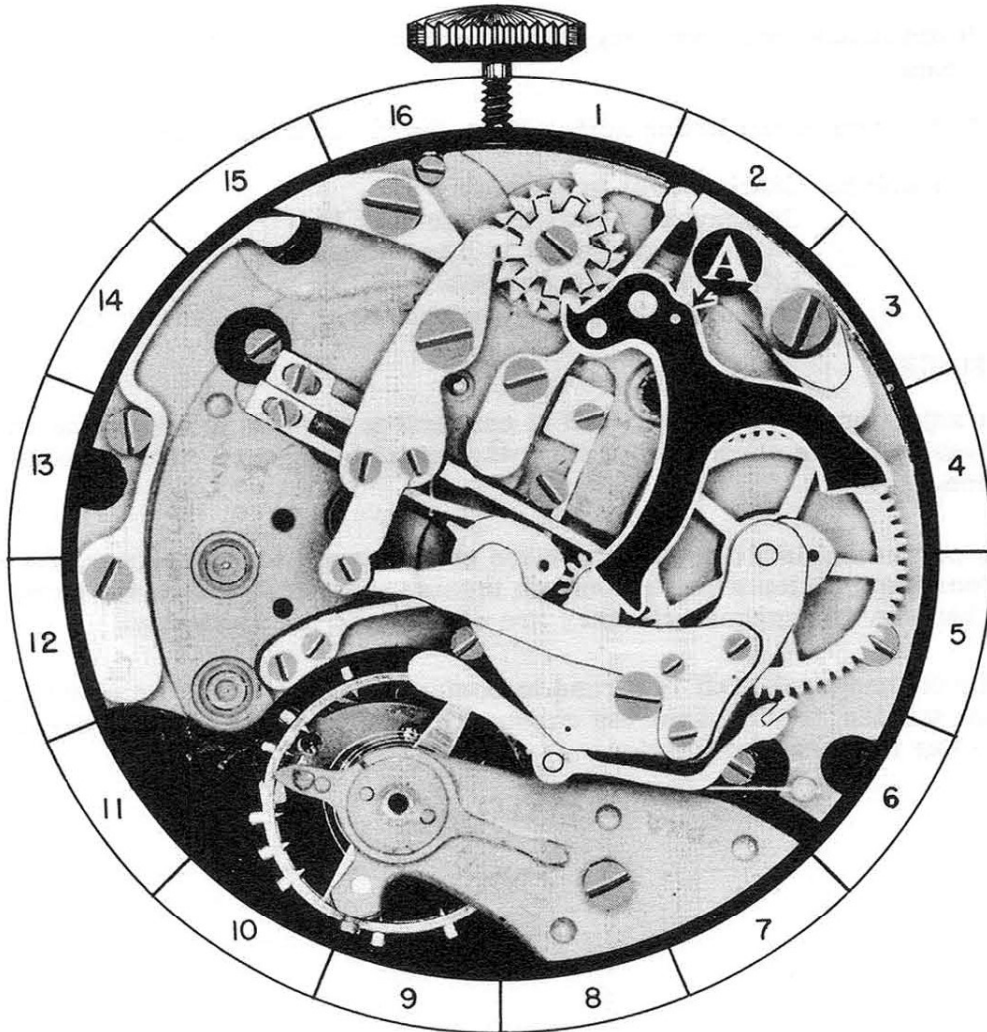

3-A

## PART NO. 4

### A. DISASSEMBLY PROCEDURE OF CONNECTING LEVER:

The connecting lever is held in place by a shouldered screw SS-1. When this screw is removed, the connecting lever can be lifted out of place.

(The shape of screw for this part is shown at bottom of page.)

### B. ASSEMBLY PROCEDURE OF CONNECTING LEVER:

Place connecting lever in proper position on plate. End "D" of lever should be between two columns on castle wheel as shown in photograph. Now replace shouldered screw SS-1 that holds connecting lever in place. Check to see that lever pivots freely under head of shouldered screw.

### C. FUNCTION OF CONNECTING LEVER:

The function of connecting lever is to do three things:

1. It forces the end "A" of engaging spring down. This engages the chronograph staff with the chronograph pinion.
2. It disengages intermediary wheel tension spring from the intermediary wheel.
3. It disengages the lifting spring from the chronograph staff.

**REFERENCE:** Castle wheel is Assembly 8.  
Chronograph staff is Assembly 17.  
Chronograph pinion is Assembly 21.  
Lifting spring is Assembly 18.  
Intermediary wheel tension spring is Assembly 12.

### REMARKS:

The adjusting screw "C" on end of connecting lever is to adjust the amount of tension on the chronograph staff when staff is engaged with chronograph pinion.

The connecting lever should force the chronograph staff to contact the chronograph pinion with just enough tension to be sure that these parts cannot become disengaged until they are disengaged mechanically.

If the chronograph staff is forced to contact the chronograph pinion with too much tension, it will cause the chronograph pinion to be excessively hard to turn due to increased friction.

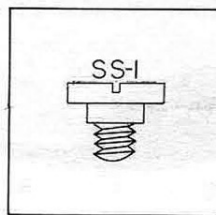



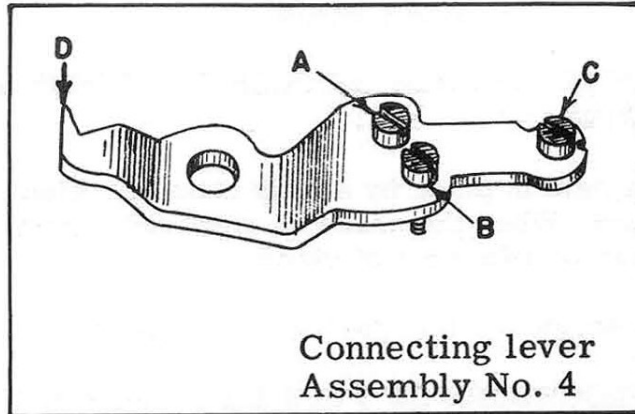

#### OILING

- These points on connecting lever should be slightly moistened with oil:
1. Shoulder of screw that connecting lever pivots on.
  2. At point screw "A" contacts intermediary wheel tension spring.
  3. At point screw "B" contacts lifting spring.
  4. At point screw "C" contacts engaging spring.

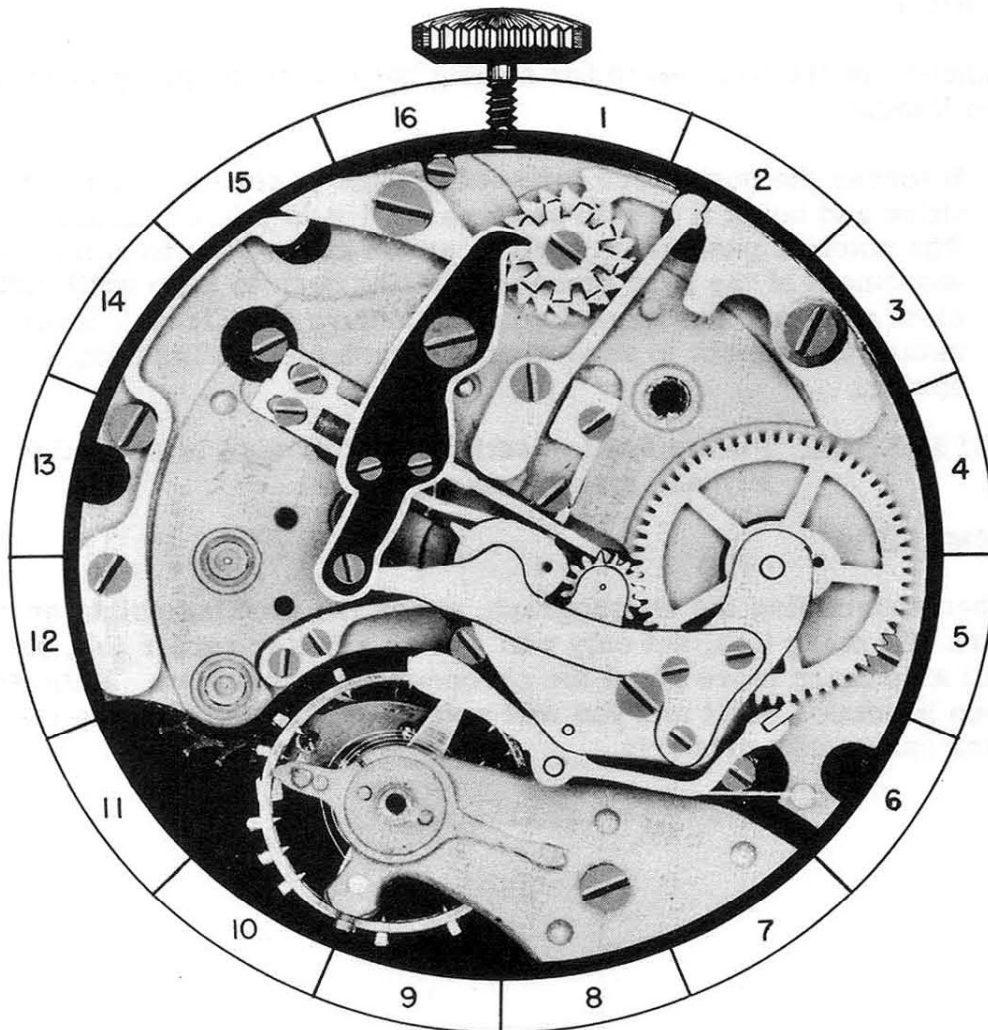

4-A

## PART NO. 5

### A. DISASSEMBLY PROCEDURE OF PUSH PIECE FOR SETTING BACK TO ZERO SPRING:

This spring is held in place by a body bound beveled screw BBS-2 and a steady pin. When the screw is removed, spring will be free on plate and can be lifted out of place.

(The shape of screw for this part is shown at bottom of page.)

### B. ASSEMBLY PROCEDURE OF PUSH PIECE FOR SETTING BACK TO ZERO SPRING:

Place spring in its proper position on plate as shown in photograph. Now replace body bound beveled screw BBS-2 that holds this spring in place. When replacing screw, make sure that the steady pin on spring fits down in proper hole in plate.

### C. FUNCTION OF PUSH PIECE FOR SETTING BACK TO ZERO SPRING:

Function of the push piece for setting back to zero spring is to do two things:

1. It forces the push piece for setting back to zero to a negative position and holds it in this position until it is pushed manually.
2. The notch in push piece spring causes this spring to retard the movement of the push piece for setting back to zero until sufficient pressure has been applied to assure that flyback lever will return the wheels to zero when the push piece slips from notch in spring.

**REFERENCE:** Push piece for setting back to zero is Assembly 6.  
Flyback lever is Assembly 3.

### REMARKS:

When assembling the chronograph, check the working points on each part. By doing this, not only will you do a better repair job, but you will also learn more about the chronograph mechanism. This will soon become a habit and you will automatically check to see that each part works properly.

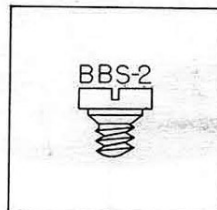

Push piece for setting back to zero  
spring Assembly No. 5

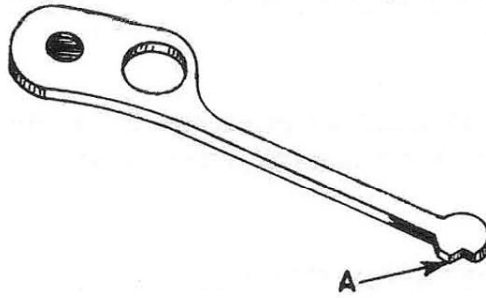

### OILING

End "A" on push piece for setting back to zero spring should be slightly moistened with oil at point it contacts push piece for setting back to zero.

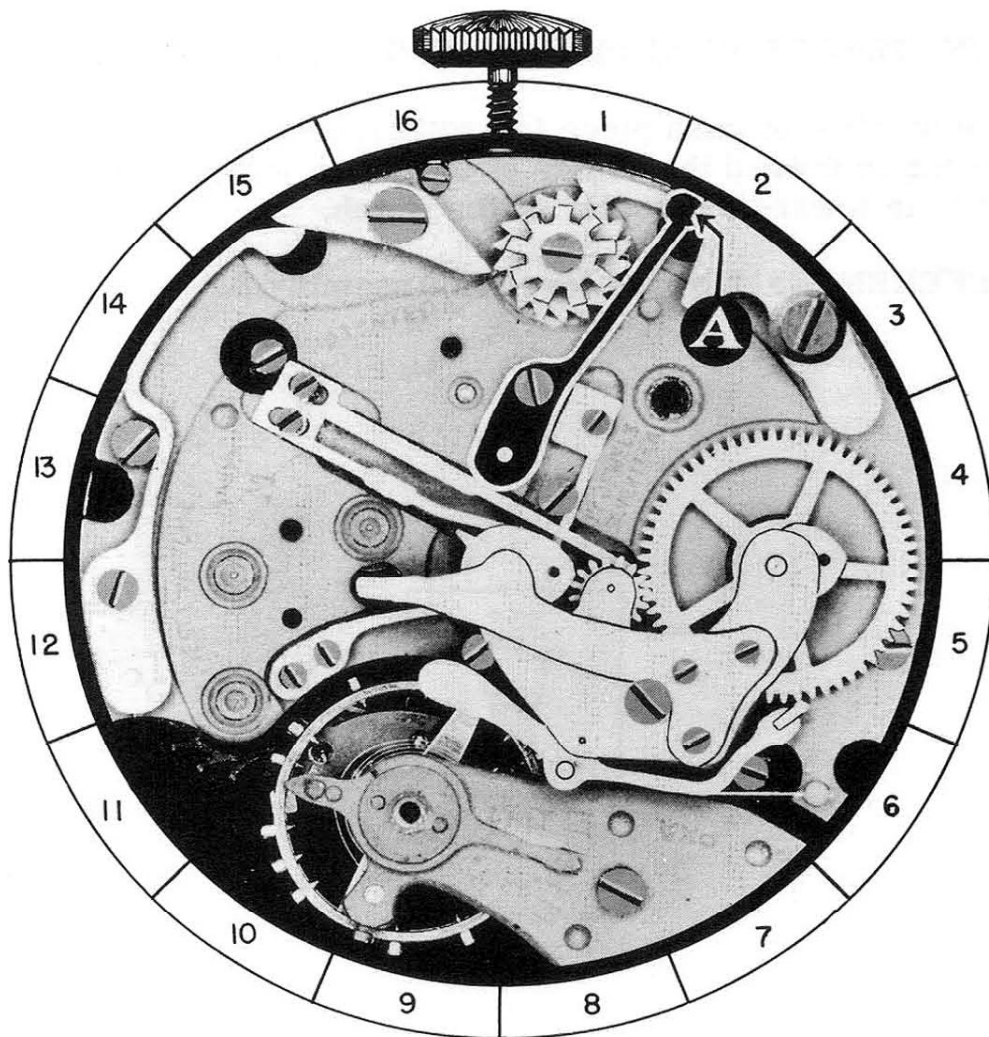

5-A

## PART NO. 6

### A. DISASSEMBLY PROCEDURE OF PUSH PIECE FOR SETTING BACK TO ZERO:

This push piece is held in position by a shouldered screw SS-2. When this screw is removed, push piece may be lifted out of place.

(The shape of screw for this part is shown at bottom of page)

### B. ASSEMBLY PROCEDURE OF PUSH PIECE FOR SETTING BACK TO ZERO:

Place push piece in its proper position on castle wheel pawl. Now replace shouldered screw SS-2 that holds push piece in its proper position. After replacing screw, check push piece to see that it pivots freely under head of this screw.

### C. FUNCTION OF PUSH PIECE FOR SETTING BACK TO ZERO:

The function of push piece for setting back to zero, is when pushed in toward the center of the watch to force the flyback lever in toward the center of the watch.

REFERENCE: Flyback lever is Assembly 3.

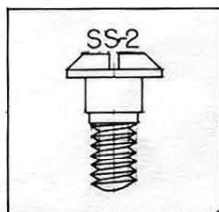

Push piece for  
setting back to zero  
Assembly No. 6

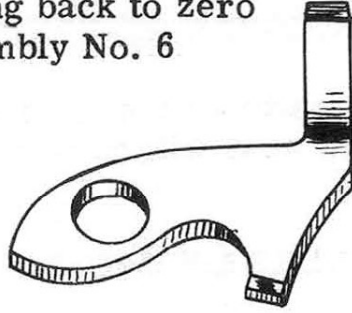

### OILING

The shoulder of screw that push piece for setting back to zero pivots on should be slightly moistened with oil.

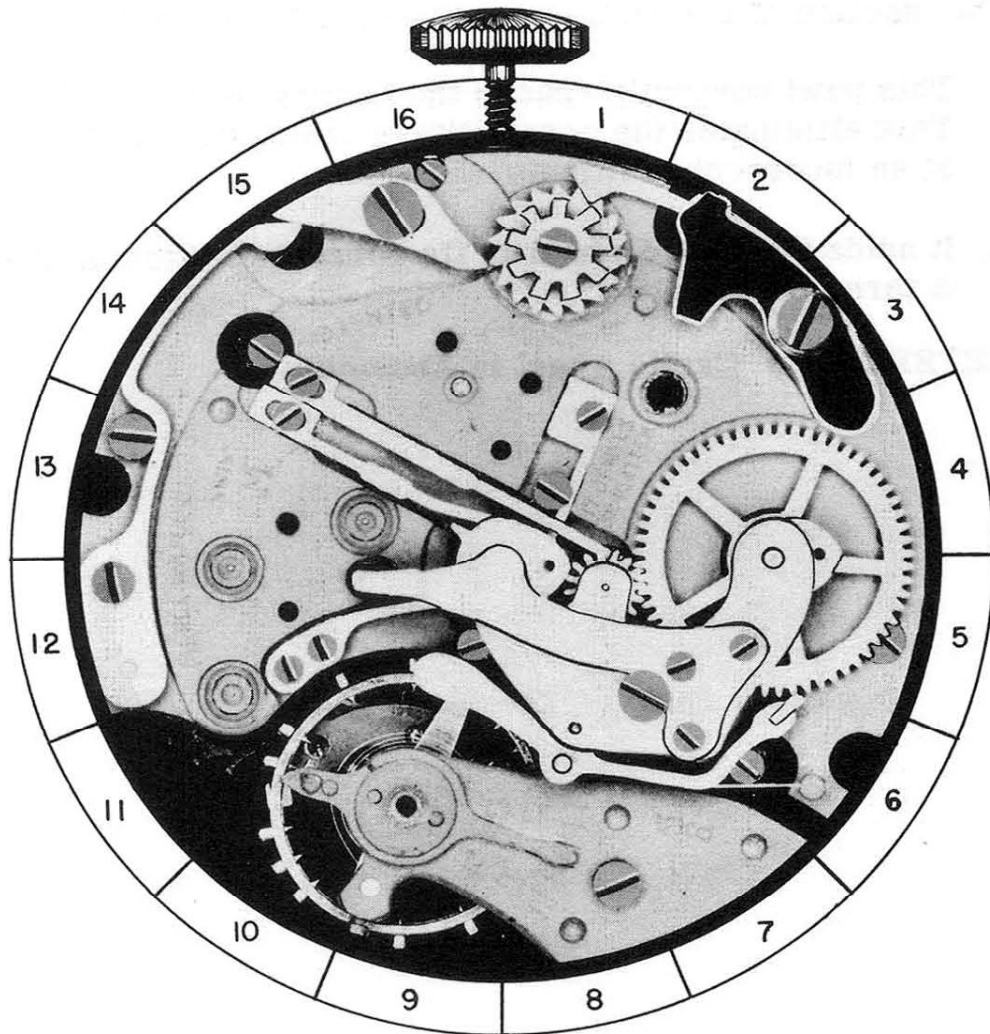

6-A

## PART NO. 7

### A. DISASSEMBLY PROCEDURE OF CASTLE WHEEL PAWL:

After push piece for setting back to zero has been lifted out of place, castle wheel pawl will be free on plate and can be removed from watch.

### B. ASSEMBLY PROCEDURE OF CASTLE WHEEL PAWL:

Place pawl in its proper position on plate as shown in photograph, with steady pin on pawl in its proper hole. The screw for pawl should not be replaced until after the next part is replaced. Make sure that end 'A' of pawl is in contact with the ratchet teeth 'B' on castle wheel.

### C. FUNCTION OF CASTLE WHEEL PAWL:

The function of the castle wheel pawl is to do two things:

1. This pawl correctly spaces the turning of the castle wheel. This eliminates the possibility of the castle wheel setting at an incorrect position.
2. It holds the castle wheel in its correct position until it is turned manually.

**REFERENCE:** Castle wheel is Assembly 8.

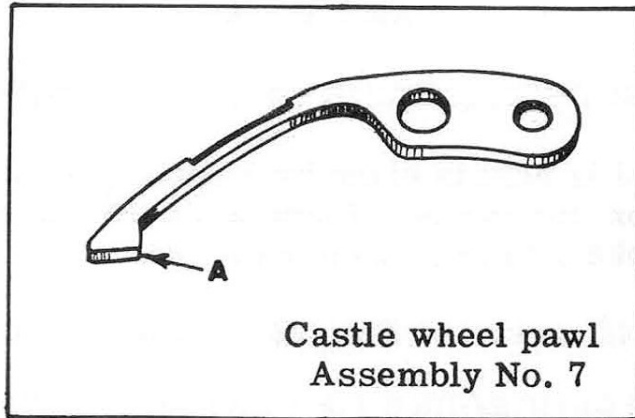

### OILING

The castle wheel pawl should not be oiled.

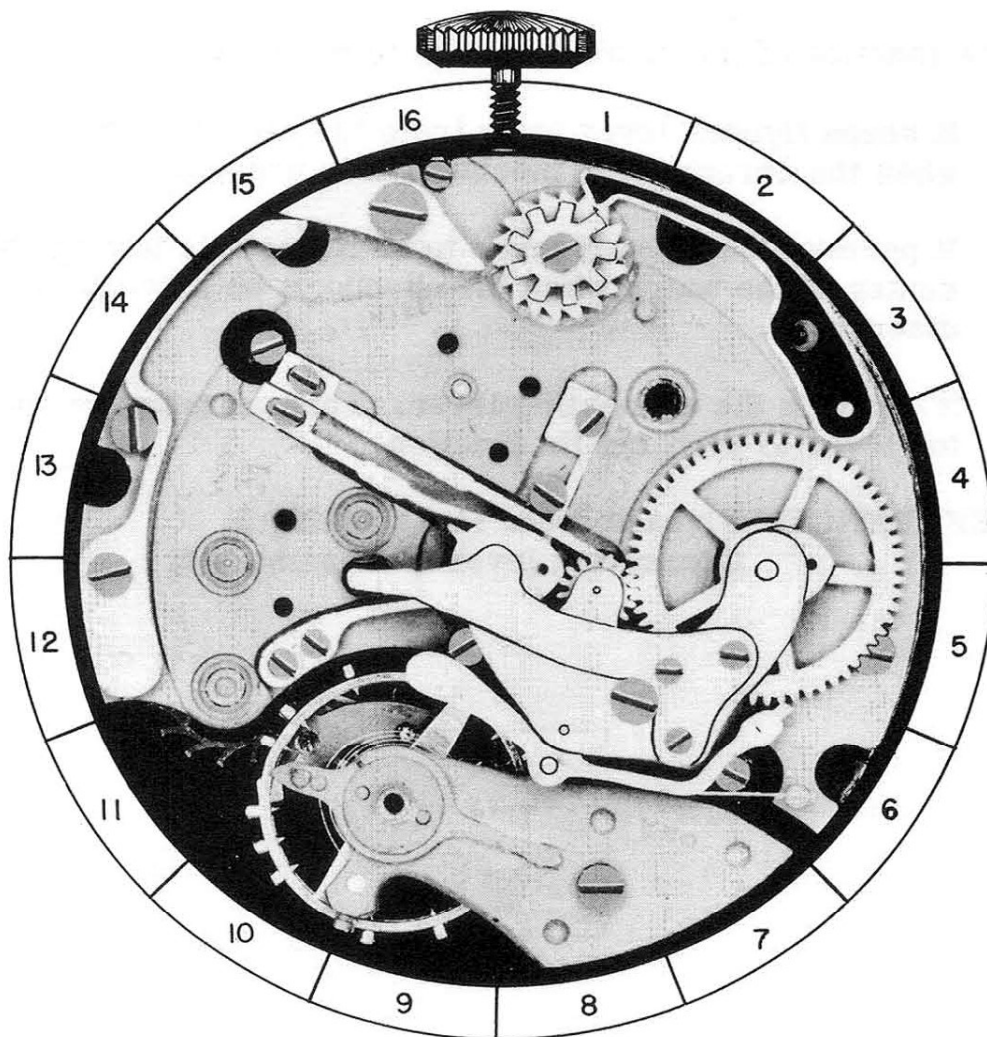

7-A

## PART NO. 8

### A. DISASSEMBLY PROCEDURE OF CASTLE WHEEL:

Castle wheel is held in place by a shouldered screw SS-3 and pivots on this screw. When this screw is removed, the castle wheel can be lifted out of place.

(The shape of screw for this part is shown at bottom of page)

### B. ASSEMBLY PROCEDURE OF CASTLE WHEEL:

Place castle wheel in its proper position on plate as shown in photograph. Now replace shouldered screw SS-3 that holds this wheel in place. The castle wheel must pivot freely under head of this screw.

### C. FUNCTION OF CASTLE WHEEL:

The function of the castle wheel is to do three things:

1. It keeps flyback lever away from the center of the watch when the chronograph mechanism is engaged.
2. It permits the flyback lever to be brought in toward the center of the watch when the chronograph mechanism is disengaged.
3. It controls the connecting lever. This permits the connecting lever to perform its function.

REFERENCE: Flyback lever is Assembly 3.  
Connecting lever is Assembly 4.

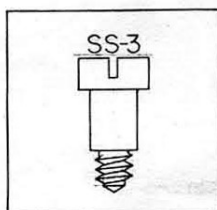



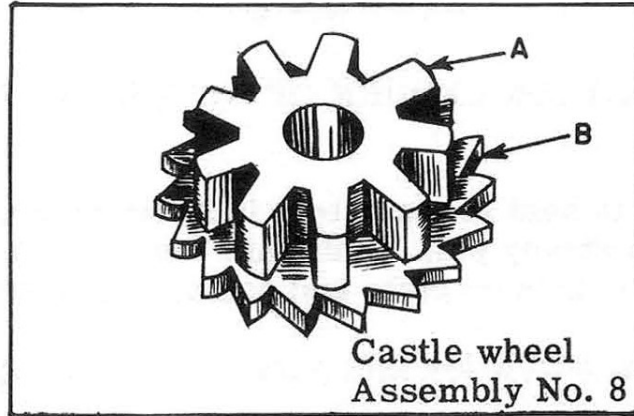

#### OILING

These parts of castle wheel should be slightly moistened with oil.

1. The shoulder of screw castle wheel pivots on.
2. The columns "A" at points of contact with parts of this mechanism.
3. The ratchet teeth "B" should be slightly moistened with oil.

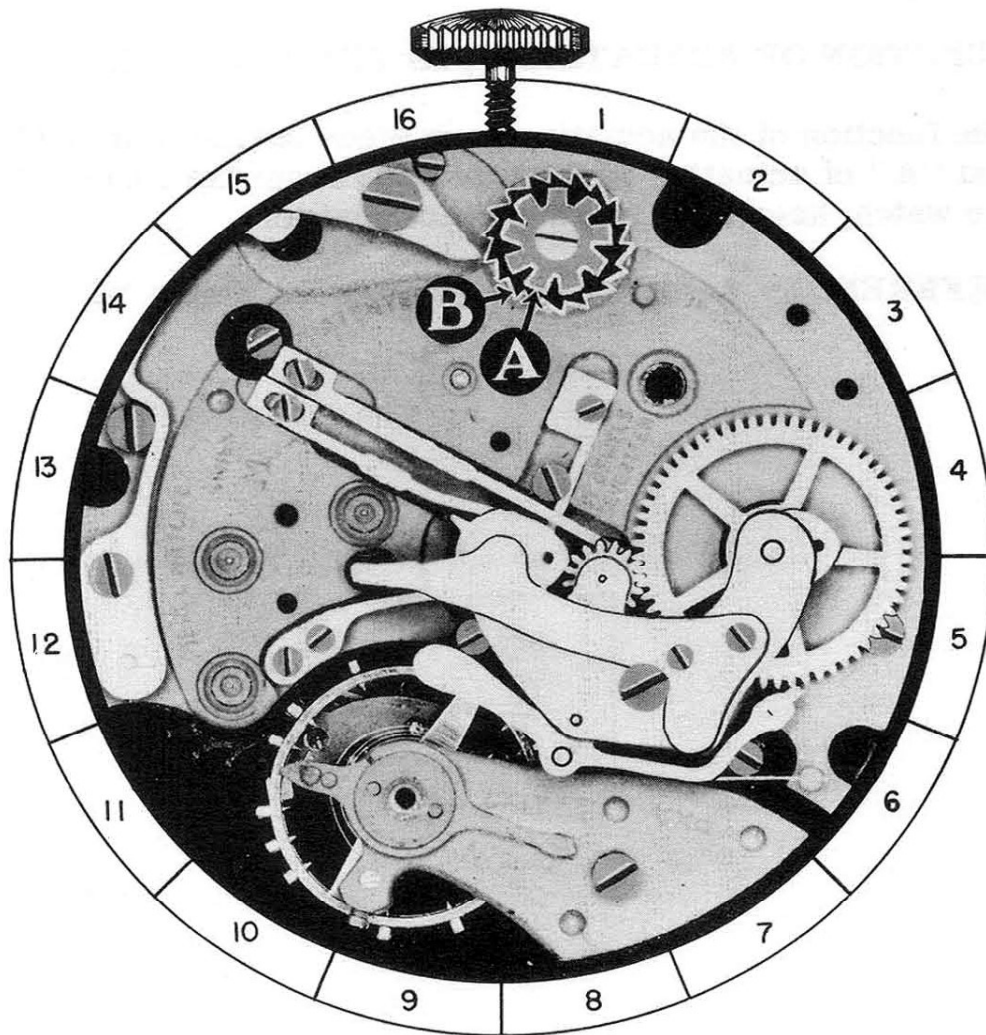

8-A

## PART NO. 9

### A. DISASSEMBLY PROCEDURE OF ACTUATING PUSH PIECE SPRING:

This spring is held in place by a body bound beveled screw, BBS-3 and a steady pin. When this screw is removed, the spring will be free on plate and can be lifted out of place.

(The shape of screw for this part is shown at bottom of page)

### B. ASSEMBLY PROCEDURE OF ACTUATING PUSH PIECE SPRING:

Place spring in its proper position on plate as shown in photograph with steady pin on spring in proper hole in plate. Now replace body bound beveled screw BBS-3 that holds this spring in place.

### C. FUNCTION OF ACTUATING PUSH PIECE SPRING:

The function of the actuating push piece spring is to hold end "A" of actuating push piece away from the center of the watch, keeping it in its correct position.

REFERENCE: Actuating push piece is Assembly 10.

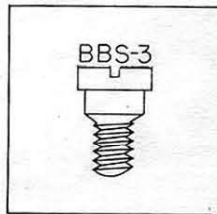

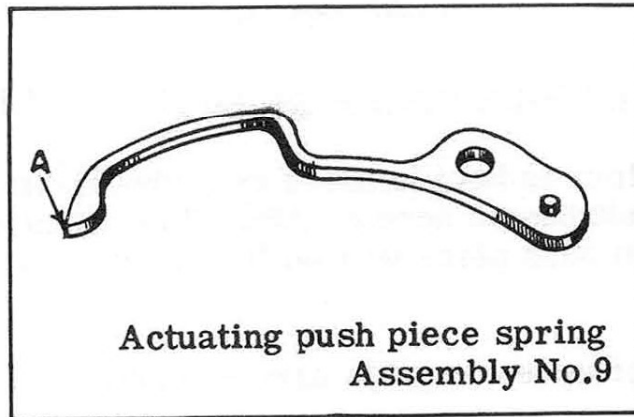

Actuating push piece spring  
Assembly No.9

### OILING

End "A" on actuating push piece spring should be slightly moistened with oil at point it contacts actuating push piece.

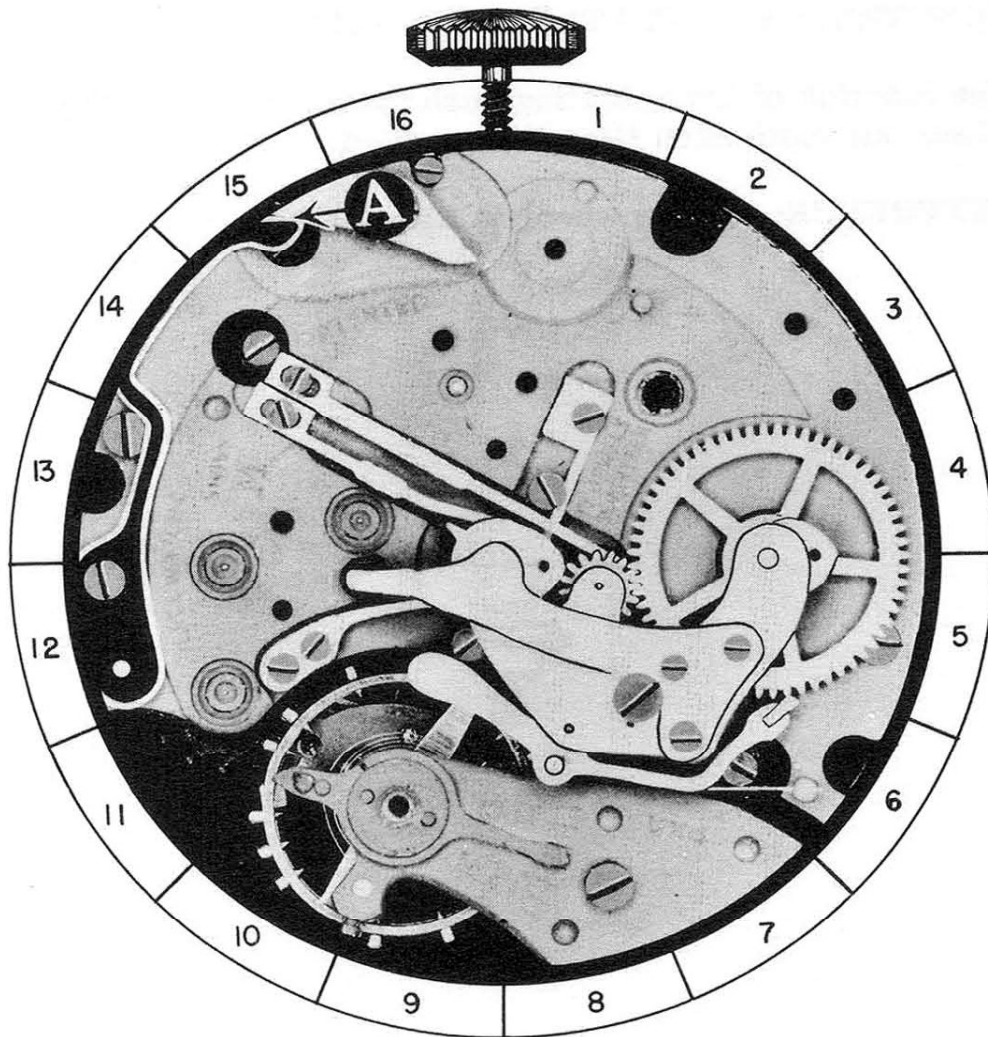

9-A

## PART NO. 10

### A. DISASSEMBLY PROCEDURE OF ACTUATING PUSH PIECE:

This push piece is held in place by a shouldered screw SS-4 which is a left thread screw. After this shouldered screw is removed, the push piece will be free on plate and can be lifted out of place.

(The shape of screw for this part is shown at bottom of page)

### B. ASSEMBLY PROCEDURE OF ACTUATING PUSH PIECE:

Place actuating push piece in its proper position on plate. Now replace left threaded shouldered screw SS-4 that holds push piece in place. After screw is replaced, check actuating push piece to see that it turns freely under head of screw.

### C. FUNCTION OF ACTUATING PUSH PIECE:

The function of the actuating push piece, is to turn the castle wheel one tooth each time it is pushed.

**REFERENCE:** Castle wheel is Assembly 8.

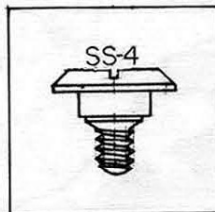

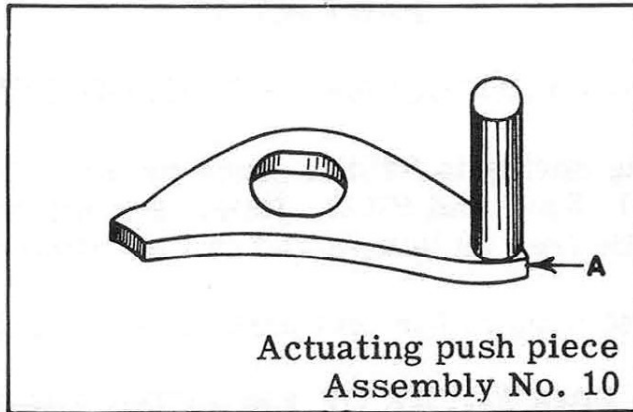

### OILING

The shoulder of screw that actuating push piece pivots on should be slightly moistened with oil.

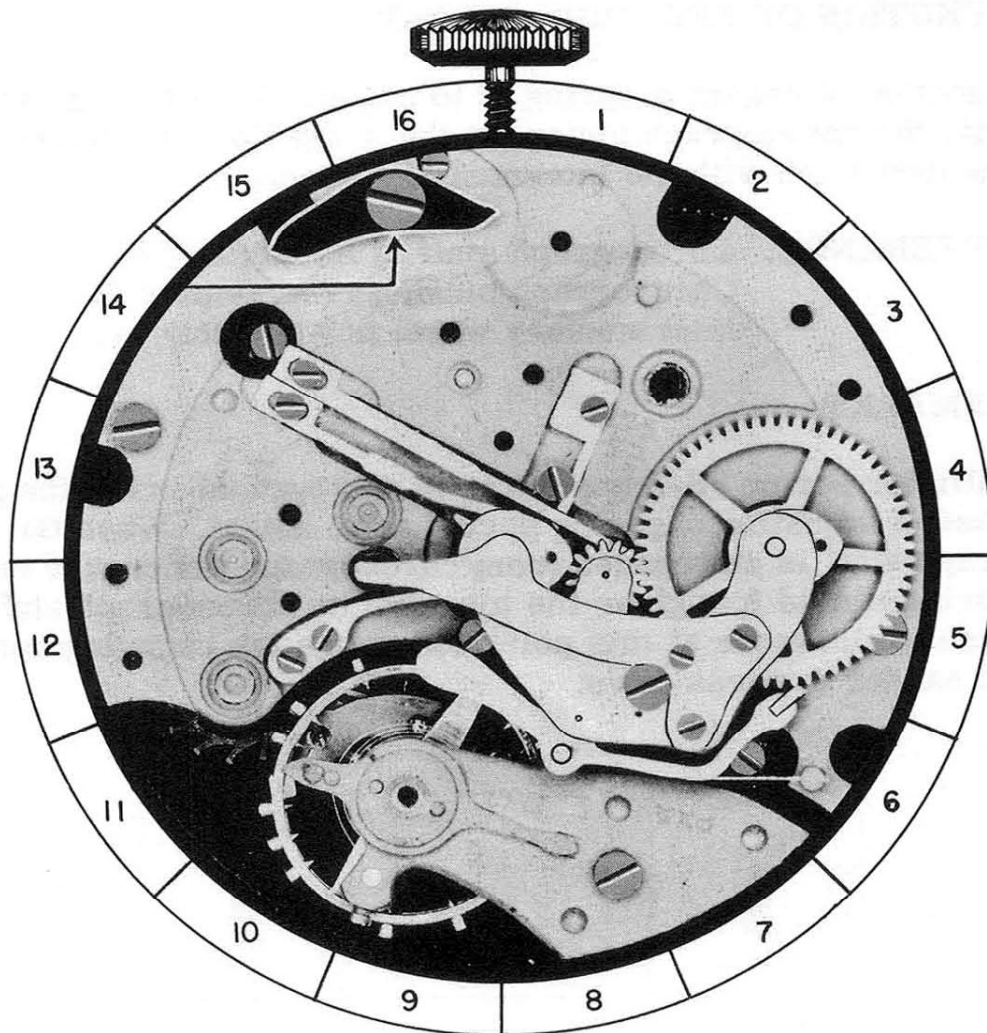

10-A

## PART NO. 11

### A. DISASSEMBLY PROCEDURE OF ENGAGING SPRING:

The engaging spring is held in place by three fillister head screws FS-1, FS-2 and FS-3. Remove these screws and spring will be free on bridge and can be lifted out of place.

(The shape of screws for this part is shown at bottom of page)

### B. ASSEMBLY PROCEDURE OF ENGAGING SPRING:

Place engaging spring in proper position on bridge as shown in photograph. Replace the three fillister head screws, FS-1, FS-2 and FS-3. There is no difference between the shape of these screws. The center fillister screw is used to make adjustments, as explained under remarks.

### C. FUNCTION OF ENGAGING SPRING:

Function of engaging spring is to engage the chronograph staff with the chronograph pinion, at the same time, it also engages the dart tooth with the intermediary wheel.

**REFERENCE:** Chronograph staff is Assembly 17.  
Chronograph pinnion is Assembly 21.  
Intermediary wheel is Assembly 16.

### REMARKS:

Fillister screw FS-3 (as shown in photograph) is for the purpose of adjusting engaging spring as to height. When the chronograph staff is disengaged from chronograph pinion, the engaging spring should just clear the top pivot on chronograph staff. Any excess clearance at this point will cause the engaging spring to be harder to press down.

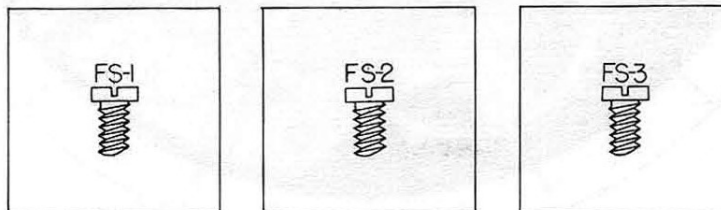

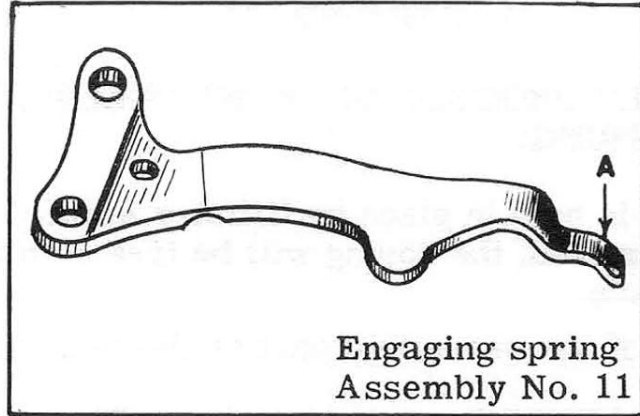

### OILING

The engaging spring should not be oiled.

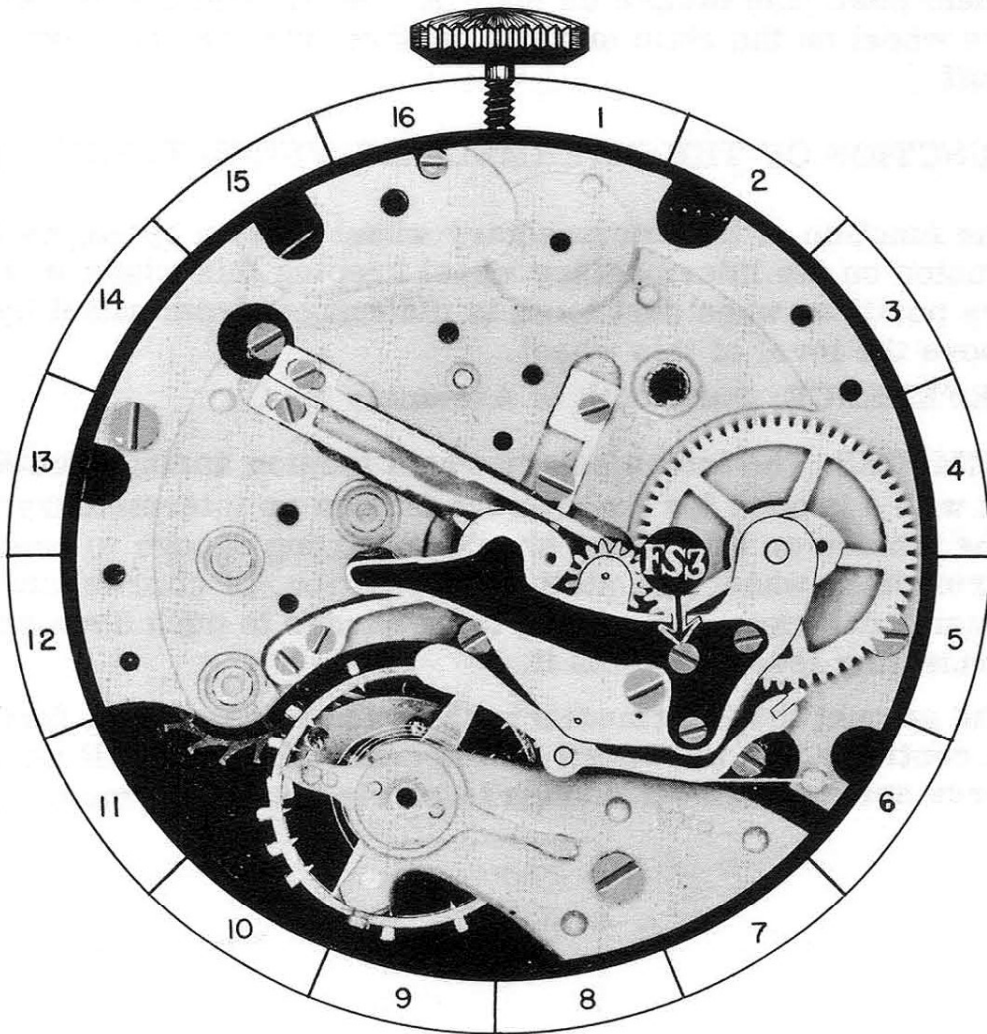

11-A

## PART NO. 12

### A. DISASSEMBLY PROCEDURE OF INTERMEDIARY WHEEL TENSION SPRING:

This spring is held in place by fillister screw FS-4. When this screw is removed, the spring will be free on plate and can be lifted out of place.

(The shape of screw for this part is shown at bottom of page)

### B. ASSEMBLY PROCEDURE OF INTERMEDIARY WHEEL TENSION SPRING:

Place tension spring in its proper position on plate with part "B" of spring up and the end "A" under the intermediary wheel. Replace fillister head screw FS-4 but before tightening screw, adjust spring so the end "A" of spring does not touch the intermediary wheel post. The dimple on end "A" should contact the intermediary wheel on the plain surface of wheel between the teeth and the staff.

### C. FUNCTION OF THE INTERMEDIARY WHEEL TENSION SPRING:

The function of the intermediary wheel tension spring is to hold a tension on the intermediary wheel keeping this wheel in a stationary position, when dart tooth is disengaged from wheel by rising above the level of this wheel.

REFERENCE: Dart tooth is Assembly 17-C.

REMARKS: The intermediary wheel tension spring should be tested with a broach for the correct tension on intermediary wheel. The tension on this wheel should be strong enough to hold the intermediary wheel in a stationary position. Of course, any excess tension can cause the spring to be harder to push down when the connecting lever contacts it.

The amount the intermediary wheel tension spring is forced down is controlled by the screw on the connecting lever. It should just force spring down far enough to safely clear intermediary wheel.

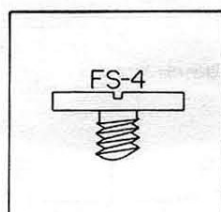



Intermediary wheel  
tension spring  
Assembly No. 12

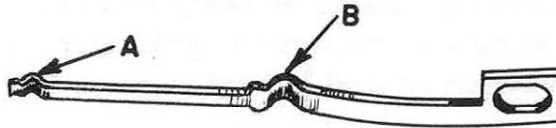

### OILING

The intermediary wheel tension spring should not be oiled.

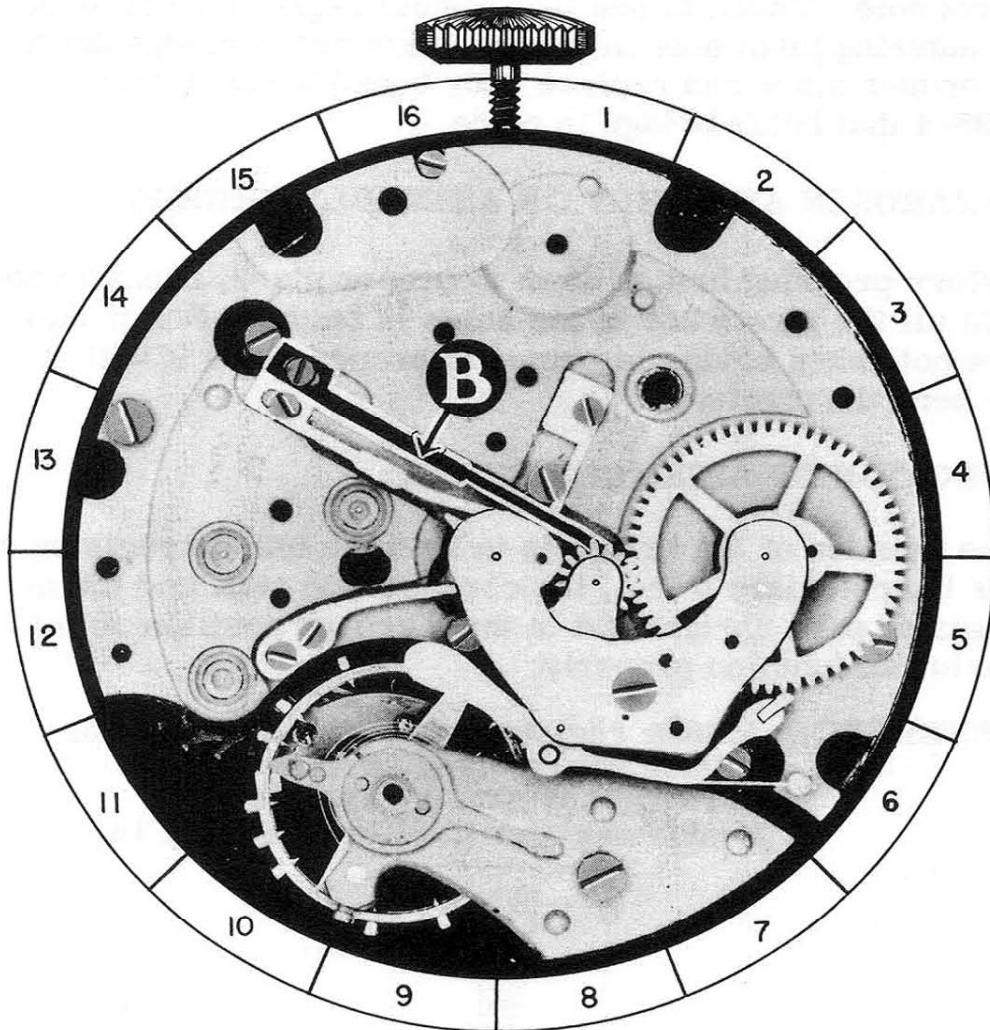

12-A

## PART NO. 13

### A. DISASSEMBLY PROCEDURE OF ASSEMBLY BRIDGE:

This bridge is held in place by body bound beveled screw BBS-4. After screw is removed, grip end "A" of bridge with a pair of tweezers and lift up to free bridge from plate.

( The shape of screw for this part is shown at bottom of page )

### B. ASSEMBLY PROCEDURE OF ASSEMBLY BRIDGE:

Place bridge in proper position as shown in photograph. Before pressing bridge down in place, check to see that all pivots are entering the proper pivot holes. Check to see that minute register wheel pivot is entering pivot hole. Check to see that chronograph staff is entering pivot hole. Check to see that intermediary wheel pivot is entering pivot hole. Check to see that minute register pawl pivot is entering pivot hole in bridge. Now press bridge down to proper place and replace body bound beveled screw BBS-4 that holds bridge in place.

### C. HAZARDS IN ASSEMBLY OF ASSEMBLY BRIDGE:

Before pressing bridge down to proper place, check to see that all the pivots are in the holes in bridge. For if they are not, when bridge is placed in proper place it will break or bend the pivots.

### D. FUNCTION OF ASSEMBLY BRIDGE:

The function of the bridge is to hold the minute register wheel, the intermediary wheel, the chronograph staff and the minute register pawl upright and in their proper position so that these parts can function properly.

**REFERENCE:** Minute register wheel is Assembly 15.  
Intermediary wheel is Assembly 16.  
Chronograph staff is Assembly 17.  
Minute register pawl is Assembly 14.

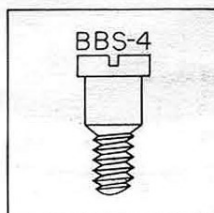

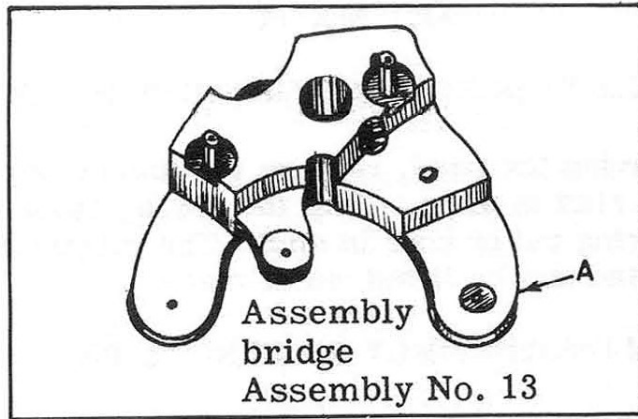

### OILING

The pivots in the bushings and jewel in this bridge should be oiled as you would properly oil a train pivot in a watch. Do not oil pivot on minute register pawl.

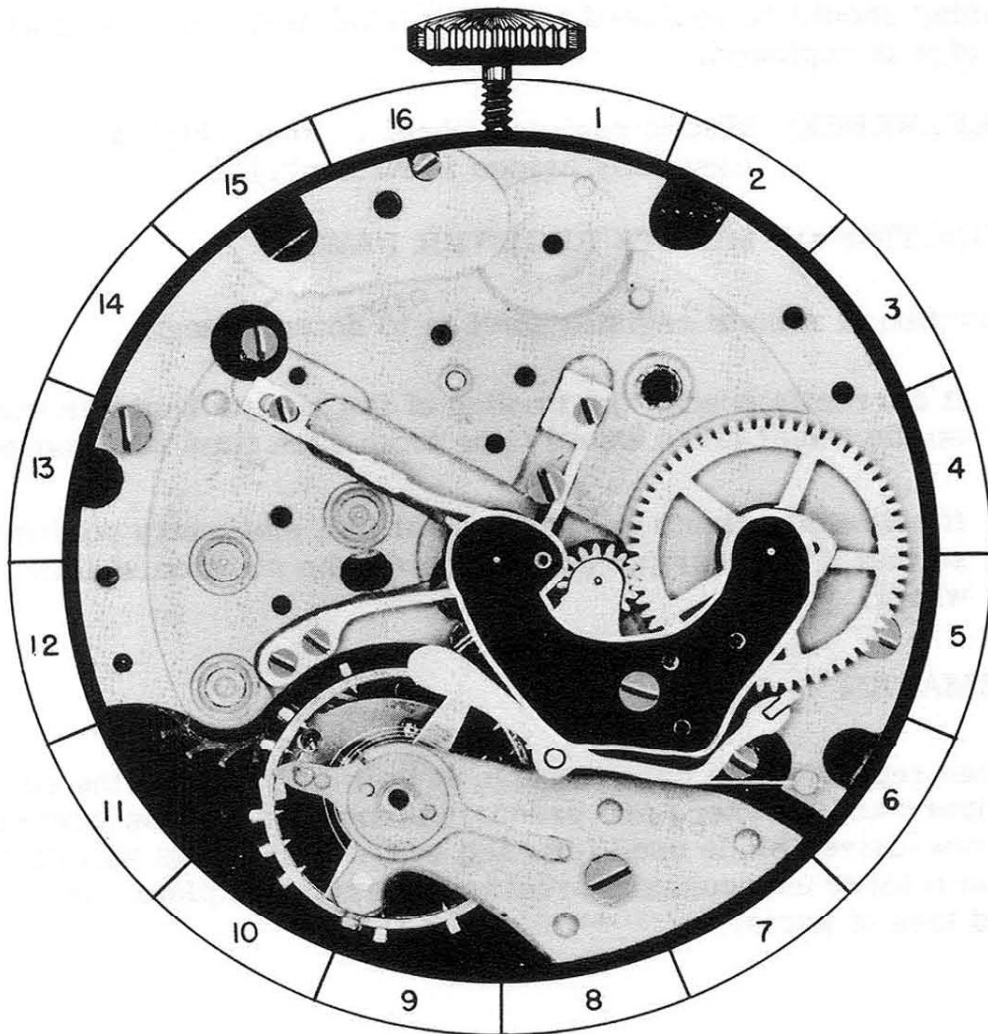

13-A

## PART NO. 14

### A. DISASSEMBLY PROCEDURE OF MINUTE REGISTER PAWL:

Before removing the pawl, remove the tension spring "A" from hole in stud in plate. Grip the spring close to the stud and slide spring out of hole in stud. The minute register pawl is now free and can be lifted out of place.

### B. HAZARDS IN DISASSEMBLY OF MINUTE REGISTER PAWL:

Care should be taken in removing this pawl so as not to bend the tension spring on pawl. This tension spring is very delicate and can easily be bent or mutilated.

### C. ASSEMBLY PROCEDURE OF MINUTE REGISTER PAWL:

Place pawl in position with the long end "B" of staff down and the pivot in pivot hole in bottom plate. The end "A" of tension spring should be replaced in hole in stud after the assembly bridge is replaced.

**REFERENCE:** Minute register wheel is Assembly 15.  
Assembly bridge is Assembly 13.

### D. FUNCTION OF MINUTE REGISTER PAWL:

Function of minute register pawl is to do two things:

1. It correctly spaces the turning of the minute register wheel so the wheel turns exactly one tooth each time it is moved.
2. It holds the minute register wheel in a stationary position so that a bump or jar cannot change the position of this wheel.

### REMARKS:

When repairing the chronograph, it is important that the screw-drivers and tweezers are properly sharpened and the correct screw-driver blade used for each screw slot. This will eliminate a lot of unnecessary breakage, marring of plates or screws, and loss of parts.

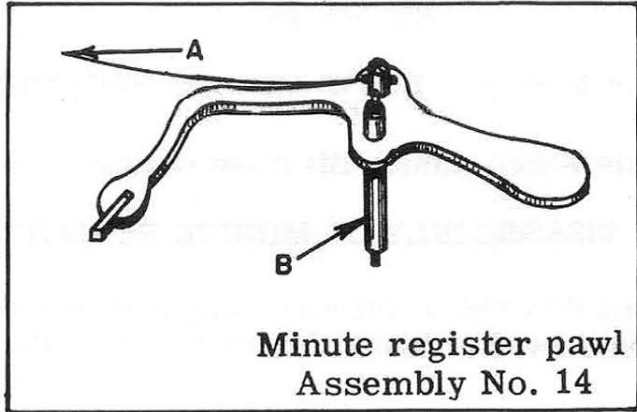

### OILING

The minute register pawl should not be oiled.

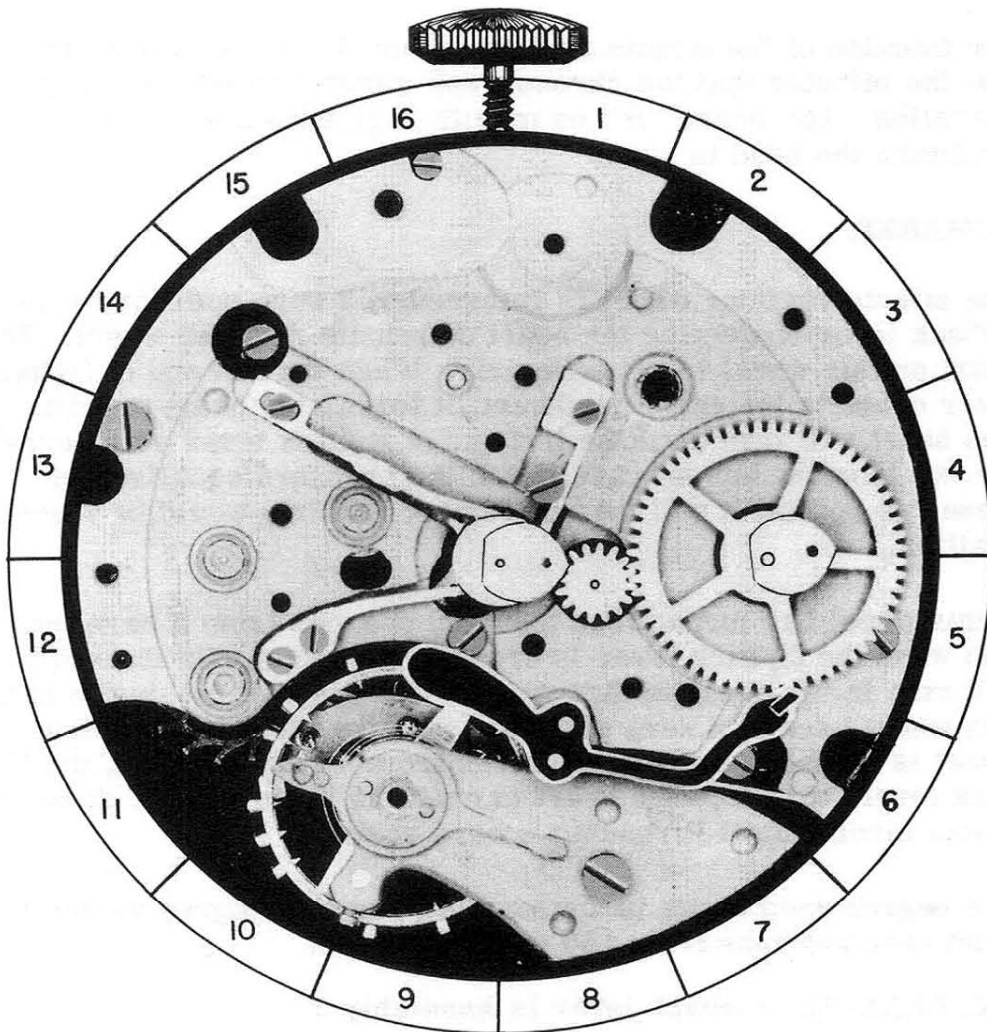

14-A

## PART NO. 15

### A. DISASSEMBLY PROCEDURE OF MINUTE REGISTER WHEEL:

To remove this wheel, simply lift it out of place.

### B. HAZARDS IN DISASSEMBLY OF MINUTE REGISTER WHEEL:

When removing this wheel, lift wheel straight up out of watch, as any twisting may bend or break the pivot on the minute register wheel.

### C. ASSEMBLY PROCEDURE OF MINUTE REGISTER WHEEL:

Place minute register wheel in its proper position in watch as shown on photograph. The long post "A" of this wheel must go down in watch.

### D. FUNCTION OF MINUTE REGISTER WHEEL:

The function of the minute register wheel is to register on the dial the minutes that the chronograph sweep second hand is in operation. The heart "B" on minute register wheel is used in returning the hand to zero.

### REMARKS:

The minute register wheel is returned to a zero position by the flyback lever contacting the heart on minute register wheel. The heart on this wheel is set eccentric. When the flat end of flyback lever contacts the eccentric heart, it forces the heart to turn. The heart will turn until the flat end of flyback lever sets across the two lobes at top of heart. With the pressure equalized at these two points, it will turn no further and this would be a zero position.

If this wheel has turned less than 160 degrees from a zero position when the flyback lever is brought in contact with the heart, it will turn in the opposite direction to which it was turning to bring this wheel back to a zero position. On the other hand, if the wheel is turned passed 160 degrees from a zero position, the flyback lever will force the heart to continue to turn in the direction it was turning until it reaches a zero position.

The degree used above is approximate, as this degree varies in most chronographs from 150 to 170 degrees.

**REFERENCE:** Flyback lever is Assembly 3.

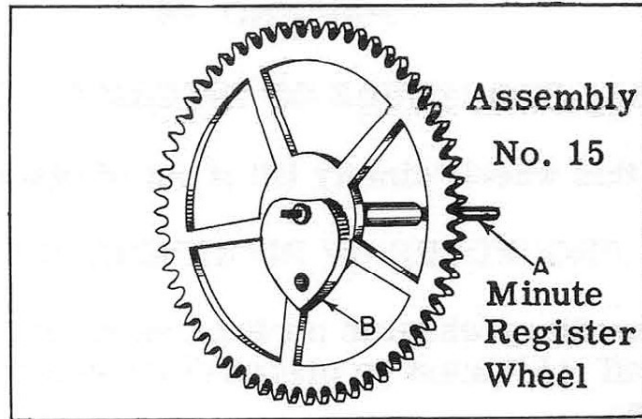

### OILING

The pivots on minute register wheel should not be oiled until after bridge for this part is placed in watch.

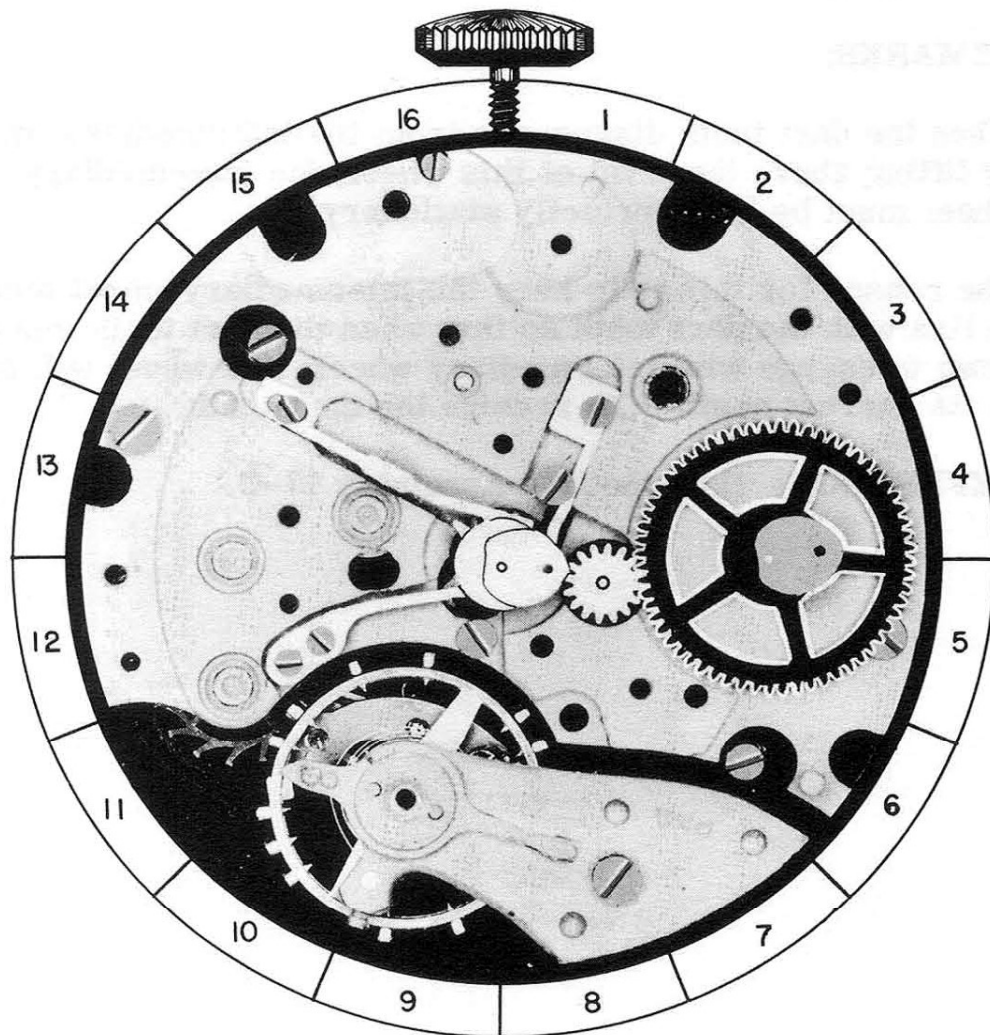

15-A

## PART NO. 16

### A. DISASSEMBLY PROCEDURE OF INTERMEDIARY WHEEL:

To remove this wheel, simply lift it out of place.

### B. ASSEMBLY PROCEDURE OF INTERMEDIARY WHEEL:

Place intermediary wheel in position as shown in photograph. The long staff "A" must be placed down with pivot in hole in bottom plate.

### C. FUNCTION OF THE INTERMEDIARY WHEEL:

Function of the intermediary wheel is to turn the minute register wheel one tooth each time the seconds wheel makes one revolution. This is done by a dart tooth attached to the chronograph staff which meshes with the intermediary wheel.

#### REMARKS:

When the dart tooth disengages from the intermediary wheel by lifting above the level of this wheel, the intermediary wheel must be held perfectly stationary.

The reason for this is to keep the intermediary wheel teeth in line with the dart tooth so that when the dart tooth moves down to engage with intermediary wheel, this wheel will be in its correct position to receive the dart tooth.

**REFERENCE:** Dart tooth is Assembly 17-C.



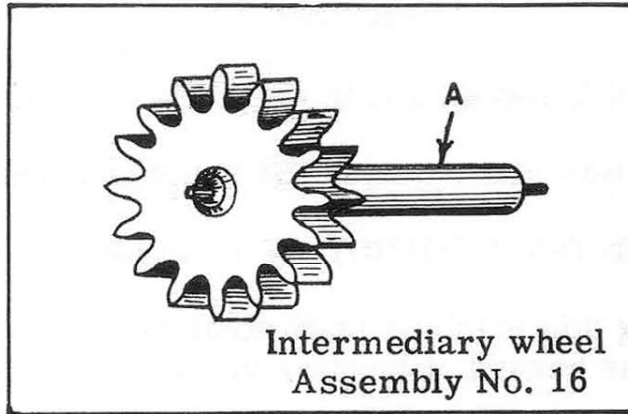

### OILING

The top and bottom pivots on intermediary wheel should not be oiled until after bridge for this part is placed in watch

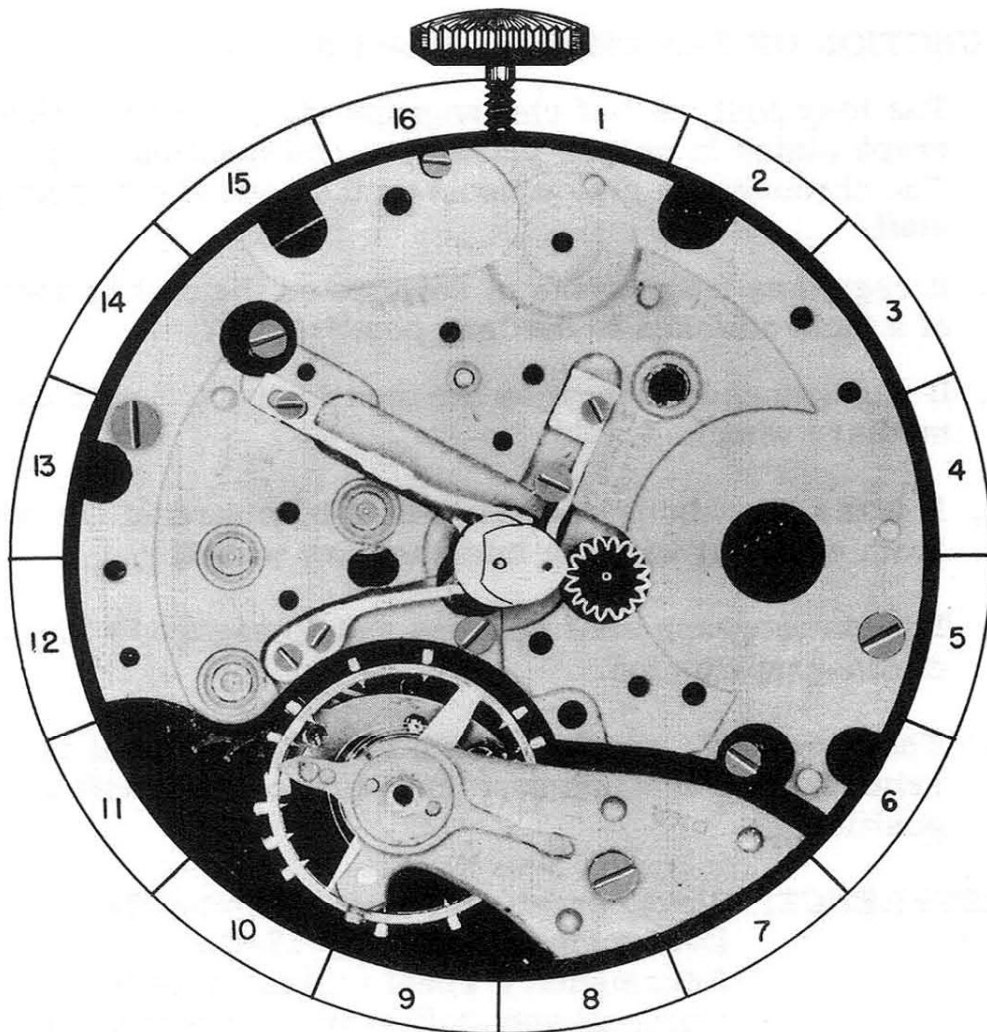

16-A

PART NO. 17

**A. DISASSEMBLY PROCEDURE OF CHRONOGRAPH STAFF:**

To remove this staff, simply lift it out of place.

**B. HAZARDS IN DISASSEMBLY OF CHRONOGRAPH STAFF:**

In removing this staff lift staff straight up out of place to eliminate the hazard of bending the pivot.

Do not clean or rinse this part in any solution, explanation on page 22.

**C. ASSEMBLY PROCEDURE OF CHRONOGRAPH STAFF:**

Place staff in its proper position on plate as shown in photograph. The long post "A" of staff must be placed down through the center hole in chronograph pinion.

**D. FUNCTION OF THE CHRONOGRAPH STAFF:**

1. The long post "A" of chronograph staff holds the chronograph pinion in proper place so it can function properly. The chronograph pinion turns on the post of chronograph staff.
2. It registers the passage of seconds on the dial by means of a hand attached to the long post "A".
3. It engages and disengages the dart tooth "C" with the intermediary wheel.
4. It turns the minute register wheel by means of the dart tooth engaging with the intermediary wheel.
5. The chronograph staff engages and disengages with the chronograph pinion.
6. The heart "B" attached to the chronograph staff is used in returning the seconds hand and chronograph staff to a zero position.

**REFERENCE:** Chronograph pinion is Assembly 21.  
Dart tooth is Assembly 17-C.  
Intermediary wheel is Assembly 16.  
Chronograph staff heart is Assembly 17-B.

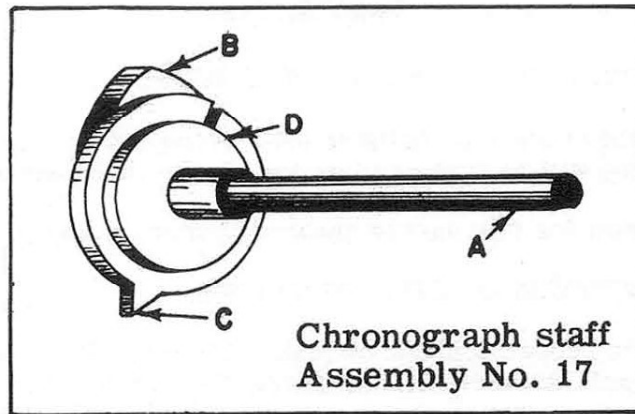

Chronograph staff  
Assembly No. 17

### OILING

The part of chronograph staff that chronograph pinion turns on should be slightly moistened with oil. The top pivot should be oiled after bridge for this part is placed in watch.

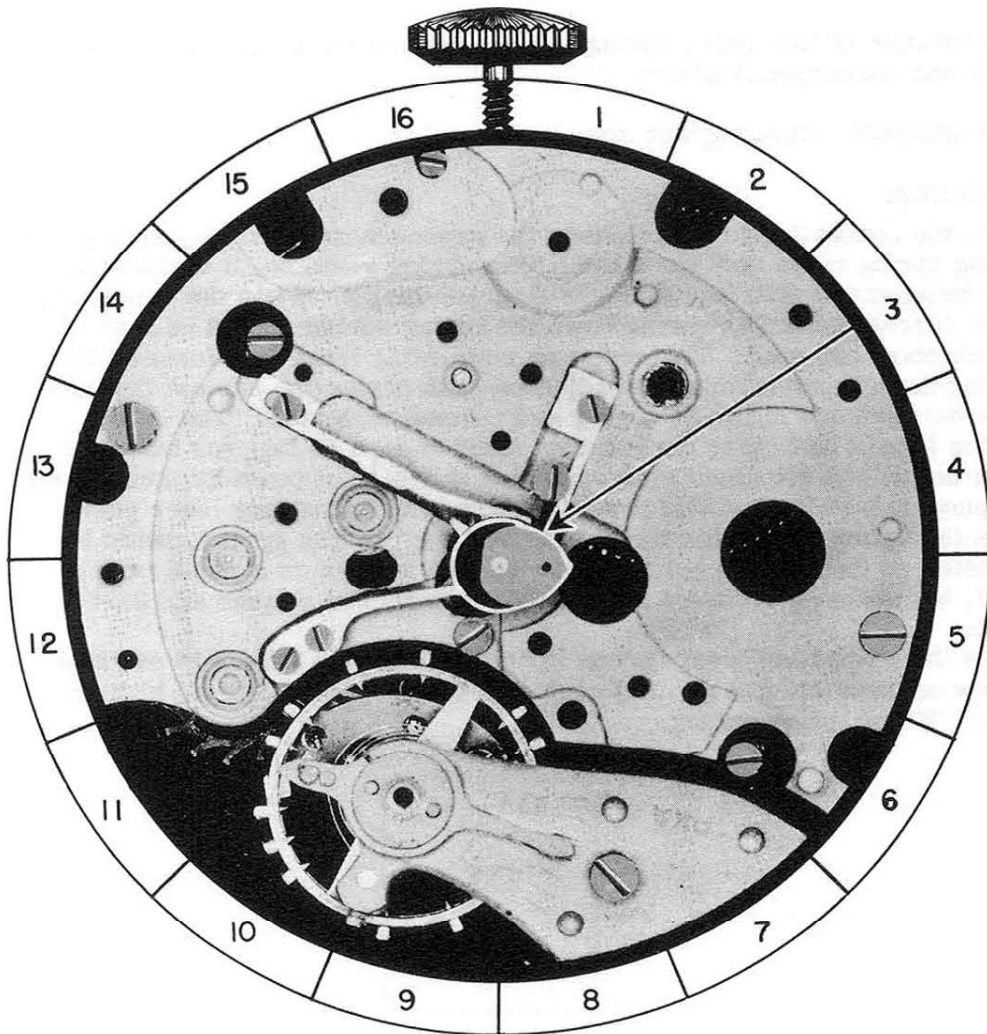

17-A

PART NO. 18

**A. DISASSEMBLY PROCEDURE OF LIFTING SPRING:**

This spring is held in place by fillister head screw FS-5. When this screw is removed, spring will be free on plate and can be lifted out of place.

(The shape of screw for this part is shown at bottom of page)

**B. ASSEMBLY PROCEDURE OF LIFTING SPRING:**

Place spring in its proper position on plate with part "B" of spring up as shown in photograph. Replace fillister screw FS-5 to hold the spring in place. The final adjustment of spring will have to be made after the chronograph staff is in place.

**C. HAZARDS IN ASSEMBLY OF LIFTING SPRING:**

Care should be taken in replacing this spring so as not to bend the spring in any way. A slight change in the shape of this spring can hinder the proper operation of the chronograph mechanism.

**D. FUNCTION OF LIFTING SPRING:**

The function of the lifting spring is to disengage the chronograph staff from the chronograph pinion.

**REFERENCE:** Chronograph staff is Assembly 17.

**REMARKS:**

When the connecting lever releases the pressure on the lifting spring the lifting spring rises up. When the lifting spring rises up, it disengages the chronograph staff from the chronograph pinion. When the connecting lever forces the lifting spring down the lifting spring should be free of the chronograph staff. The screw on connecting lever that forces lifting spring down is adjustable. By adjusting this screw you can set the clearance between end of lifting spring and chronograph staff. The lifting spring should just clear chronograph staff enough so that you would be sure that it had sufficient clearance that it could not possibly touch when chronograph staff is at this position. When the connecting lever permits the lifting spring to rise up, the end "A" of this spring should be adjusted so that it does not touch the rubber washer on chronograph staff, but rides on the plain surface between rubber washer and dart tooth.

When the connecting lever forces lifting spring down, check to see that screw on connecting lever that contacts lifting spring is at the highest point "B" of lifting spring.

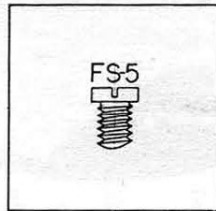

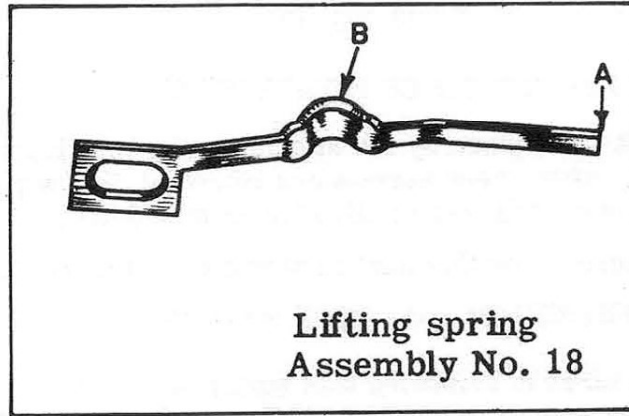

### OILING

The lifting spring should not be oiled.

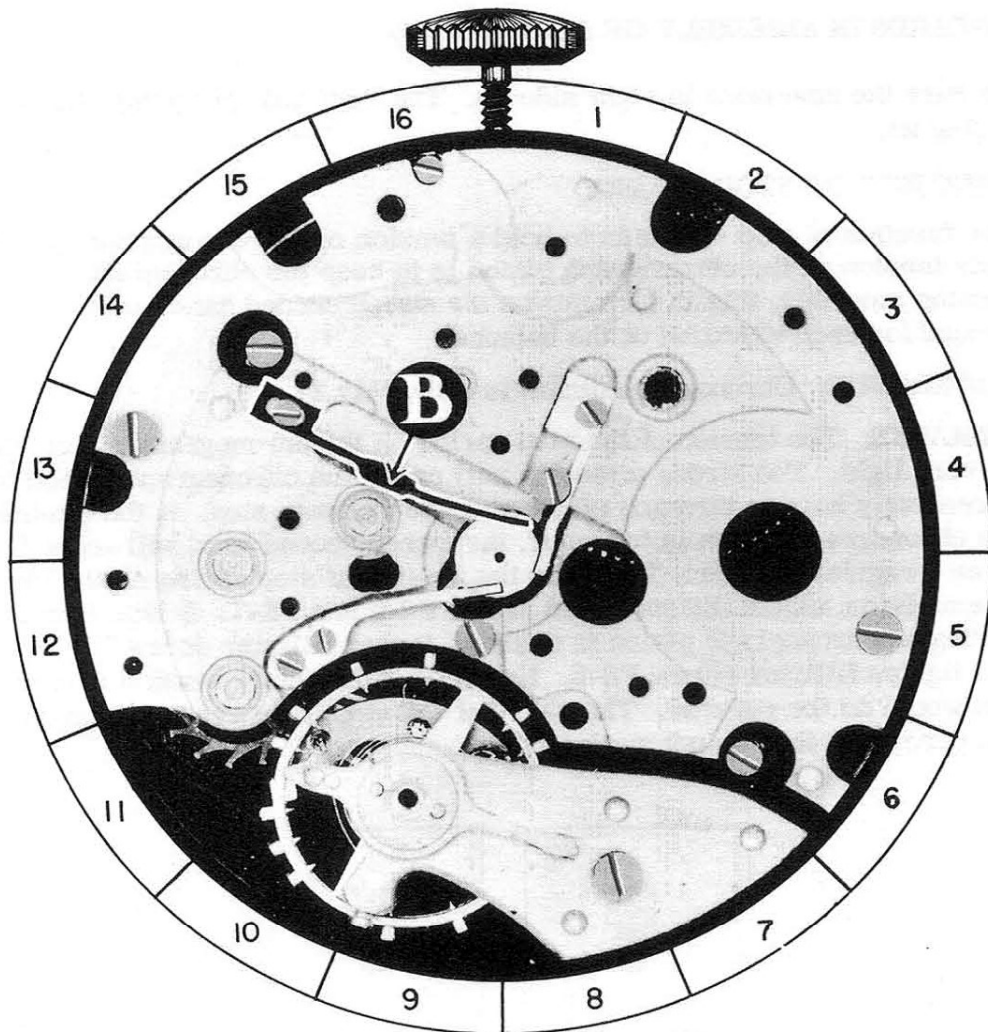

18-A

## PART NO. 19

### A. DISASSEMBLY PROCEDURE OF STOP SPRING:

This spring is held in place by the stop plate and two fillister head screws FS-6 and FS-7. After these screws are removed, the stop plate and spring will be free on plate and may be lifted from movement.

(The shape of screws for this part is shown at bottom of page)

### B. HAZARDS IN DISASSEMBLY OF STOP SPRING:

Care should be taken in removing this spring so as not to bend or mutilate the spring in any way. A slight bend in this spring can hinder the proper operation of this chronograph.

### C. ASSEMBLY PROCEDURE OF STOP SPRING:

Place spring in its proper position on plate as shown in photograph. Place stop plate on spring with end "A" toward center of watch and the "B" side of plate up. Now replace the two fillister head screws FS-6 and FS-7 that hold this spring in place.

### D. HAZARDS IN ASSEMBLY OF STOP SPRING:

Be sure the stop plate is right side up. The "B" side of spring should be facing up.

### E. FUNCTION OF STOP SPRING:

The function of stop spring is to hold a tension on the chronograph pinion. This tension on the chronograph pinion is to keep the chronograph pinion turning smoothly, this in turn moves the sweep second hand one-fifth of a second for each vibration of the balance.

**REFERENCE:** Chronograph pinion is Assembly 21.

**REMARKS:** The tension of the stop spring on the chronograph pinion should be very light. Too strong a tension will cause the chronograph pinion to be excessively hard to turn and may cause the watch to stop. If the tension on the chronograph pinion is too weak, the sweep second hand will move forward in an irregular manner. To adjust the tension of stop spring on the chronograph pinion, adjust fillister head screw FS-6 and FS-7. If less tension of spring on chronograph pinion is desired, loosen fillister screw FS-7 slightly and tighten fillister screw FS-6. Naturally, when more tension is desired you would do the reverse. The shape of the stop plate keeps a tension on the screws so they do not work loose.

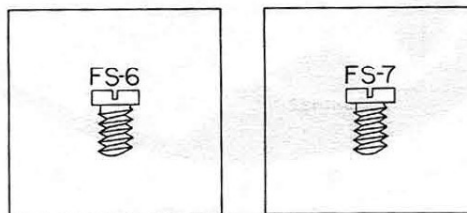

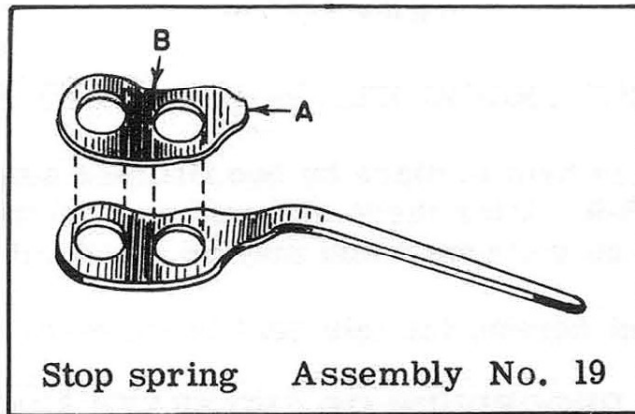

Stop spring Assembly No. 19

### OILING

The stop spring should not be oiled.

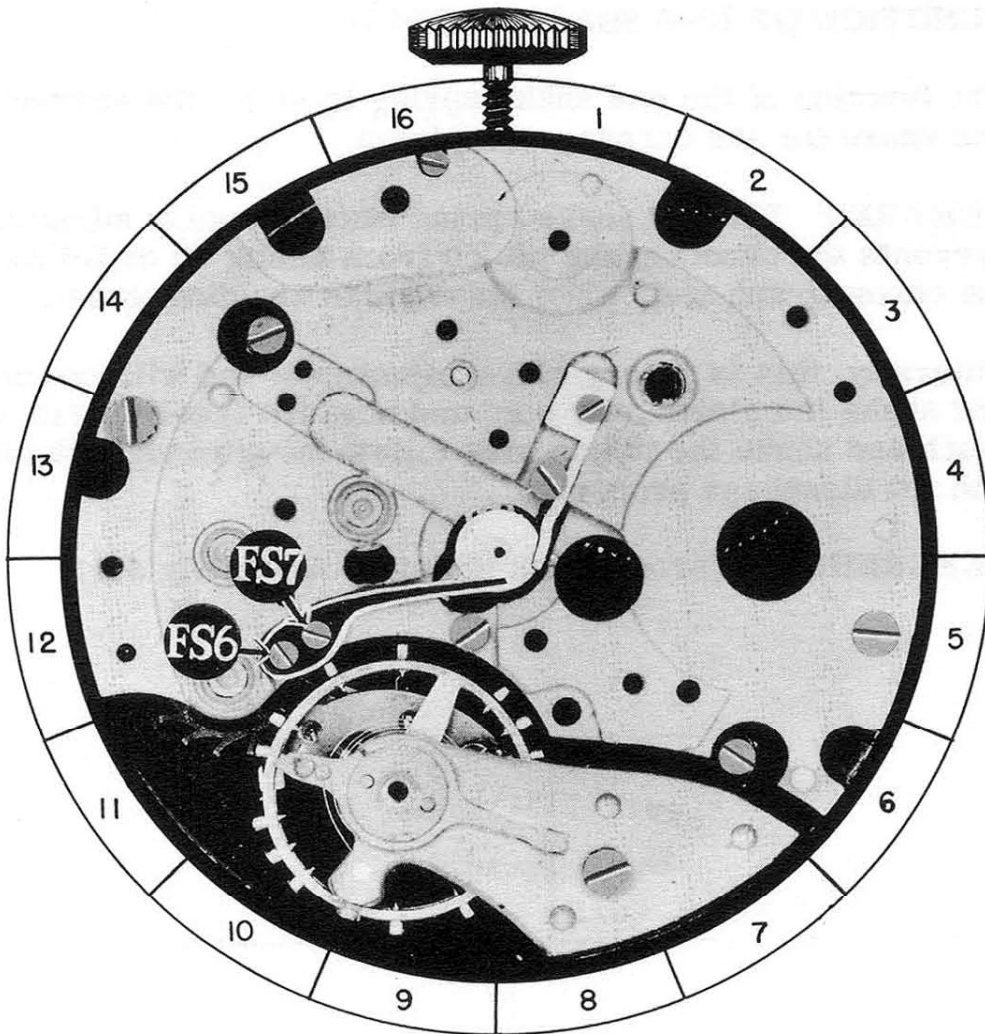

19-A

## PART NO. 20

### A. DISASSEMBLY PROCEDURE OF END SHAKE SPRING:

This spring is held in place by two fillister head screws FS-8 and FS-9. After these screws are removed, spring will be free on movement and may be lifted out of place.

(The shape of screws for this part is shown at bottom of page)

### B. ASSEMBLY PROCEDURE OF END SHAKE SPRING:

Place spring in position on plate with part "A" of spring down. Replace fillister screw FS-8 that holds spring in place. Now replace fillister screw FS-9 in place. This screw is to adjust the end "B" of spring to give the correct end shake to the chronograph pinion.

### C. FUNCTION OF END SHAKE SPRING:

The function of the end shake spring is to set the correct end shake for the chronograph pinion.

**REMARKS:** The end shake spring when properly adjusted, prevents the chronograph pinion from riding up or following the chronograph staff when these parts are disengaged.

Naturally, this is a very close adjustment and with not enough end shake the pinion may bind and not turn freely. With too much end shake the pinion may follow the chronograph staff and not disengage properly.

**REFERENCE:** Chronograph pinion is Assembly 21.

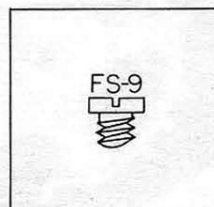
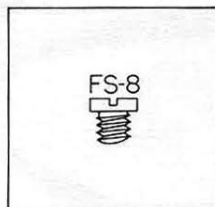



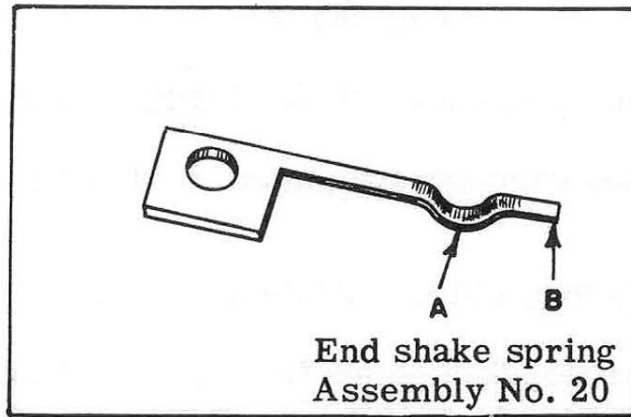

### OILING

The end shake spring should not be oiled.

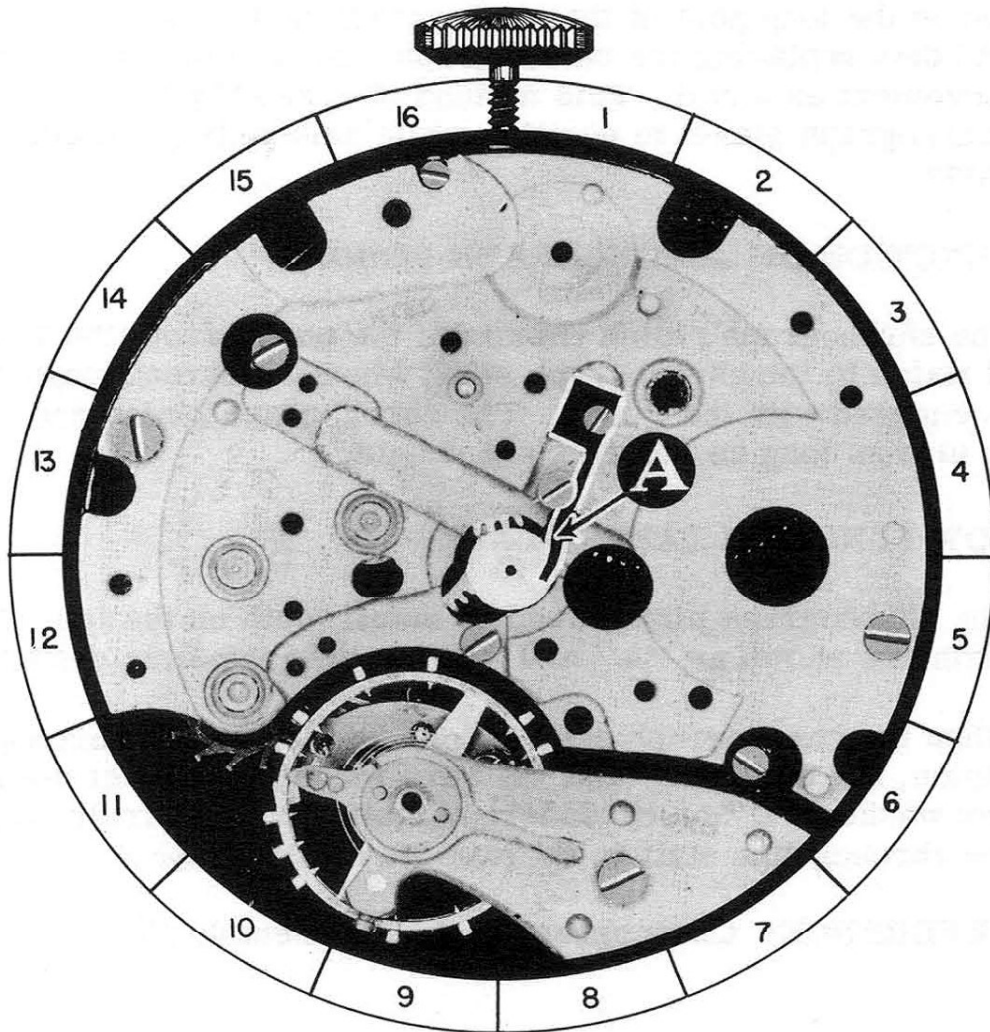

20-A

## PART NO. 21

### A. DISASSEMBLY PROCEDURE OF CHRONOGRAPH PINION:

To remove the chronograph pinion, it is simply lifted out of place.

### B. ASSEMBLY PROCEDURE OF CHRONOGRAPH PINION:

Place the chronograph pinion in proper position with hole in center of pinion over center hole in plate. The teeth on pinion must be engaged with the teeth on third wheel, as the pinion receives the power to run the chronograph from the third wheel.

NOTICE

NOTICE

NOTICE

The chronograph pinion can be replaced by placing this pinion on the long post of the chronograph staff (Part No. 17), and then replacing the chronograph staff and pinion in the movement as a unit. This method of assembly holds the chronograph pinion in position while assembling the other parts.

### C. FUNCTION OF CHRONOGRAPH PINION:

The chronograph pinion transmits the power from the train of watch to the chronograph staff, when the chronograph staff is engaged with the pinion. The chronograph pinion continues to turn as long as the watch is running.

### D. HOW FUNCTION TAKES PLACE:

The chronograph pinion has two small teeth on the top. These teeth are shown as "A" and "B" on the isometric drawing.

When the chronograph staff is forced down on the chronograph pinion, the teeth "A" and "B" are forced to contact the rubber washer "D" on chronograph staff. This naturally turns the chronograph staff to operate the chronograph.

REFERENCE: Chronograph staff is Assembly 17.

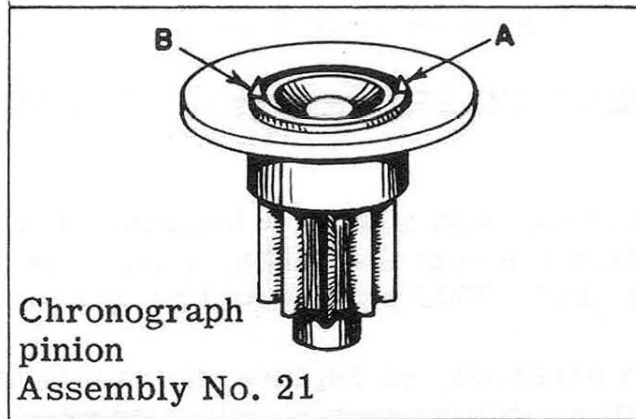

### OILING

The chronograph pinion should not be oiled.

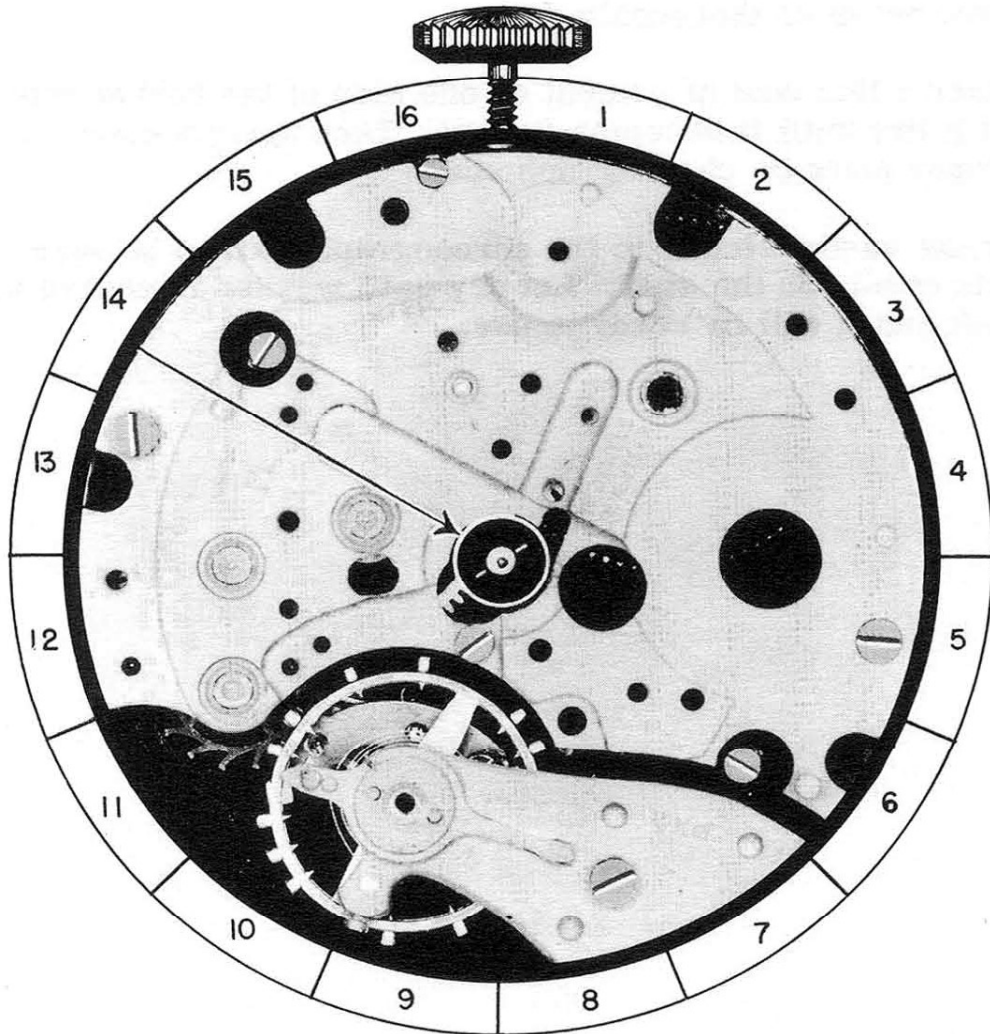

21-A

**CLEANING CHRONOGRAPH STAFF AND REPLACING RUBBER WASHER:**

Do not put the chronograph staff in a cleaning or a rinsing solution as the solution can ruin the rubber washer or loosen it from the chronograph staff. This part should be brushed to clean it.

Many times it is necessary to replace the rubber washer on the chronograph staff as this washer is only cemented on and easily becomes loose. The procedure to use in replacing this washer is as follows:

1. Apply a thin coat of rubber cement to the chronograph staff where the rubber washer is going to be placed.
2. Let the wheel set for approximately 15 minutes until the cement becomes thoroughly dry.
3. Place a thin coat of cement on one side of the rubber washer, let it dry until it becomes 'tacky'. Then apply washer to proper place on chronograph staff.
4. Press washer firmly to the chronograph staff to be sure it sets evenly on the staff. Let dry until washer is secure to staff and it will be ready to use.

## FUNCTIONAL RESULTS

After completely assembling the chronograph with the exception of back of case, place chronograph in front of you, pendant up, with back of chronograph facing you.

1. Push button at right of pendant, hold in this position, and check the following:

(Make sure castle wheel is in proper position so button can be pushed.)

- A. Check to see that minute register wheel and chronograph staff return the hands connected to these wheels to a zero position.

**CORRECTION:** The following errors could prevent these hands from returning to a zero position:

1. Loose hands or hands not being set correctly.
2. The chronograph staff or the minute register wheel binding and not turning freely.
3. The branch "A" or "B" of flyback lever not being correct length to return one of the wheels to a zero position.

### REMARKS:

The branches "A" and "B" of flyback lever must be of correct length to function properly. While holding the flyback lever in toward the center of watch, the chronograph staff and the minute register wheel should be tested for turning with a fine broach.

The flyback lever should hold the chronograph staff absolutely stationary, but it is an advantage that the minute register wheel turn slightly. The advantage of the movement of the minute register wheel is that it will make sure the greatest pressure is applied to the chronograph heart by the flyback lever. It is important that the flyback lever hold the greatest pressure against the chronograph heart, as this will make sure that the chronograph staff will always return to a zero position.

The amount the minute register wheel turns should not be enough to permit the minute register pawl to move to another tooth, but the pawl should always center itself between the same teeth.

2. Release button and check the following:

- A. Check to see that flyback lever returns to its original position.  
(Continued on next page)

**FUNCTIONAL RESULTS**  
(Continued)

**CORRECTION:** The following errors could prevent the flyback lever from returning to its original position:

1. Flyback lever spring not holding enough tension on flyback lever.
  2. Flyback lever not turning freely on post in plate.
3. Push button at left of pendant and check the following:
- A. Check to see that intermediary wheel tension spring is disengaged from intermediary wheel.

**CORRECTION:** The following errors could prevent the disengaging of this spring:

1. Intermediary wheel spring being improperly adjusted under screw-head.
  2. Improperly adjusted adjustment screw.
- B. Check to see that lifting spring is disengaged from chronograph staff.

**CORRECTION:** The following errors could prevent the lifting spring from disengaging from chronograph staff:

1. Incorrect adjustment of lifting spring under screw-head.
  2. Incorrect adjustment of adjusting screw could prevent the disengaging of this spring.
4. Push button at left of pendant, release it, and check the following:
- A. Check to see that connecting lever is disengaged from engaging spring.

**CORRECTION:** The following errors may prevent the connecting lever from disengaging from engaging spring:

1. Connecting lever spring not holding proper tension on connecting lever.
  2. Connecting lever binding and not turning freely.
- B. Check to see that engaging spring is disengaged from chronograph staff.

(Continued on next page)

**FUNCTIONAL RESULTS**  
(Continued)

**CORRECTION:** The following error could prevent the engaging spring from completely disengaging from chronograph staff:

1. Improper adjustment of adjusting screw may cause these parts not to disengage.

C. Check to see that chronograph staff is disengaged from chronograph pinion and the dart tooth disengaged from the intermediary wheel.

**CORRECTION:** The following errors may prevent the disengagement of these parts:

1. Lifting spring not having enough tension to lift chronograph staff.
2. Improper adjustment of adjusting screw.
3. Improperly adjusted hands may prevent these parts from disengaging.

D. Check to see that intermediary wheel lifting spring contacts intermediary wheel before the dart tooth is completely disengaged from intermediary wheel.

**CORRECTION:** Improper adjustment of adjusting screw will usually cause the improper coordination of engaging the intermediary wheel lifting spring with intermediary wheel before the complete disengagement of dart tooth from intermediary wheel.

E. Check to see that the sweep second hand moves forward in a steady manner with no irregular jumping or jerking.

**CORRECTION:** The following error could cause the sweep second hand to move forward in an irregular manner:

1. The stop spring not holding proper tension on chronograph staff.

## THE TACHOMETER

- A. The tachometer is used to indicate the speed of an object in miles per hour. A tachometer can only indicate the average speed of an object traveling over a course of a measured mile.

### METHOD OF USING TACHOMETER

1. Start chronograph sweep second hand at the exact moment the object starts to travel the measured distance of one mile.
2. When the object has traveled the course of one mile, stop the chronograph sweep second hand. The point on the tachometer scale where the sweep second hand stopped will indicate the average speed in miles per hour.

### SPLIT SECOND SCALE

- B. This scale is divided into 300 divisions, each division indicating  $1/5$  of a second. Every fifth division is marked with extra long lines denoting one second.

The main purpose of this scale is to measure a fraction of a second accurately.

### MINUTE REGISTER

- C. The minute register hand indicates on the dial the number of minutes that have elapsed since the beginning of the registration of the sweep second hand. One complete revolution of the minute register hand indicates the passage of one hour.

### SECOND HAND

- D. The second hand indicates the passing of seconds and should move one space each second. One complete revolution of hand denotes passage of one minute. This hand is independent of chronograph mechanism and continues to register the seconds as long as the watch is running.

### TELEMETER

- E. The telemeter is used to denote the number of miles between two points. This is done by comparing the speed of light to the speed of sound.

### METHOD OF USING TELEMETER

1. Start chronograph sweep second hand when you see lightning.
2. Stop the chronograph sweep second hand when you hear the thunder. The point on the telemeter scale where the sweep second hand stopped will indicate the distance in miles the lightning is away from you.



# THE CHRONOGRAPH DIAL

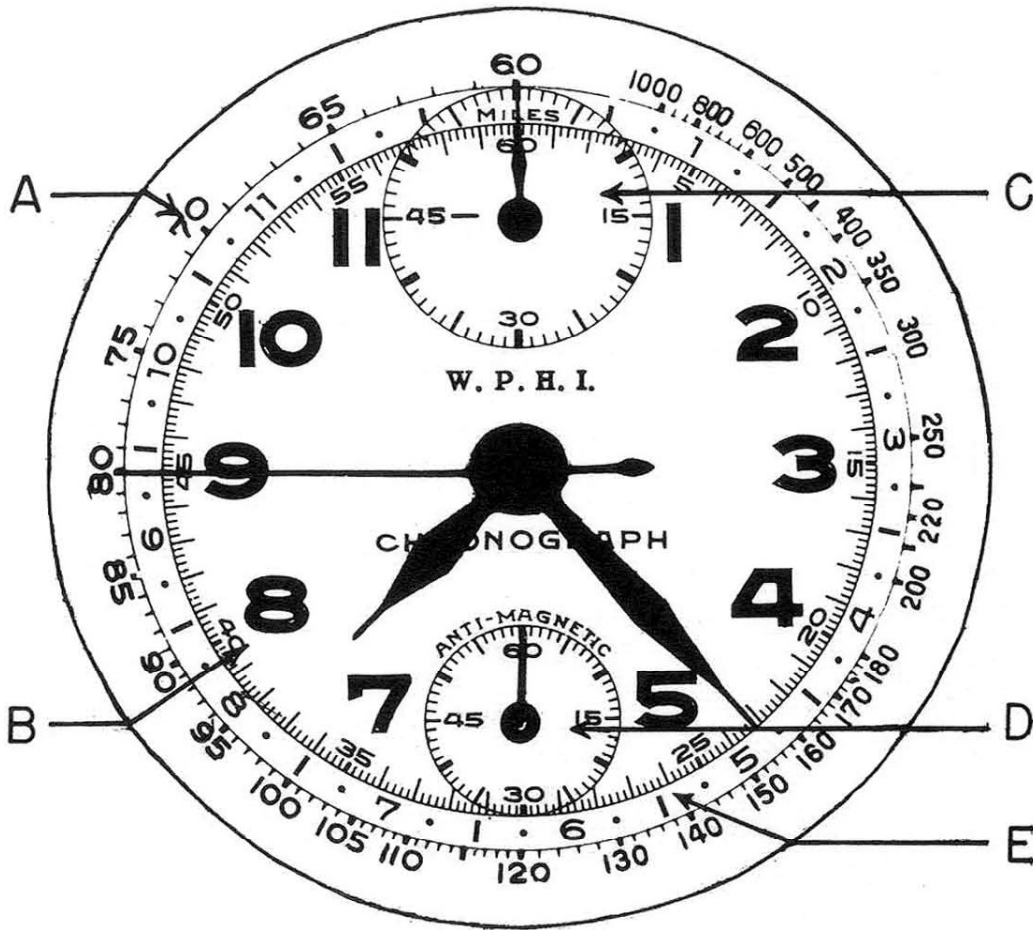

## SETTING THE HANDS CORRECTLY ON A CHRONOGRAPH

After the chronograph is completely assembled and in working condition, place chronograph in its case. Now replace the hour hand, minute hand and second hand as you would on a regular watch. At this point, do not replace the sweep second or the minute register hand. Now push the button and bring the flyback lever in toward the center of the watch. When the flyback lever is held in toward the center of the watch, place the sweep second hand at 60 on split second scale "B". Place the minute register hand at 60 on minute register scale "C". After these hands are replaced, start chronograph mechanism with sweep second hand turning. Let chronograph mechanism run for at least one minute; now push the button to bring the flyback lever in toward the center of the watch again, and check to see that the minute register hand and the sweep second hand goes back to their original position.