

WORLD'S ONLY
FULLY ILLUSTRATED
CHRONOGRAPH WATCH COURSE
VOLUME 17

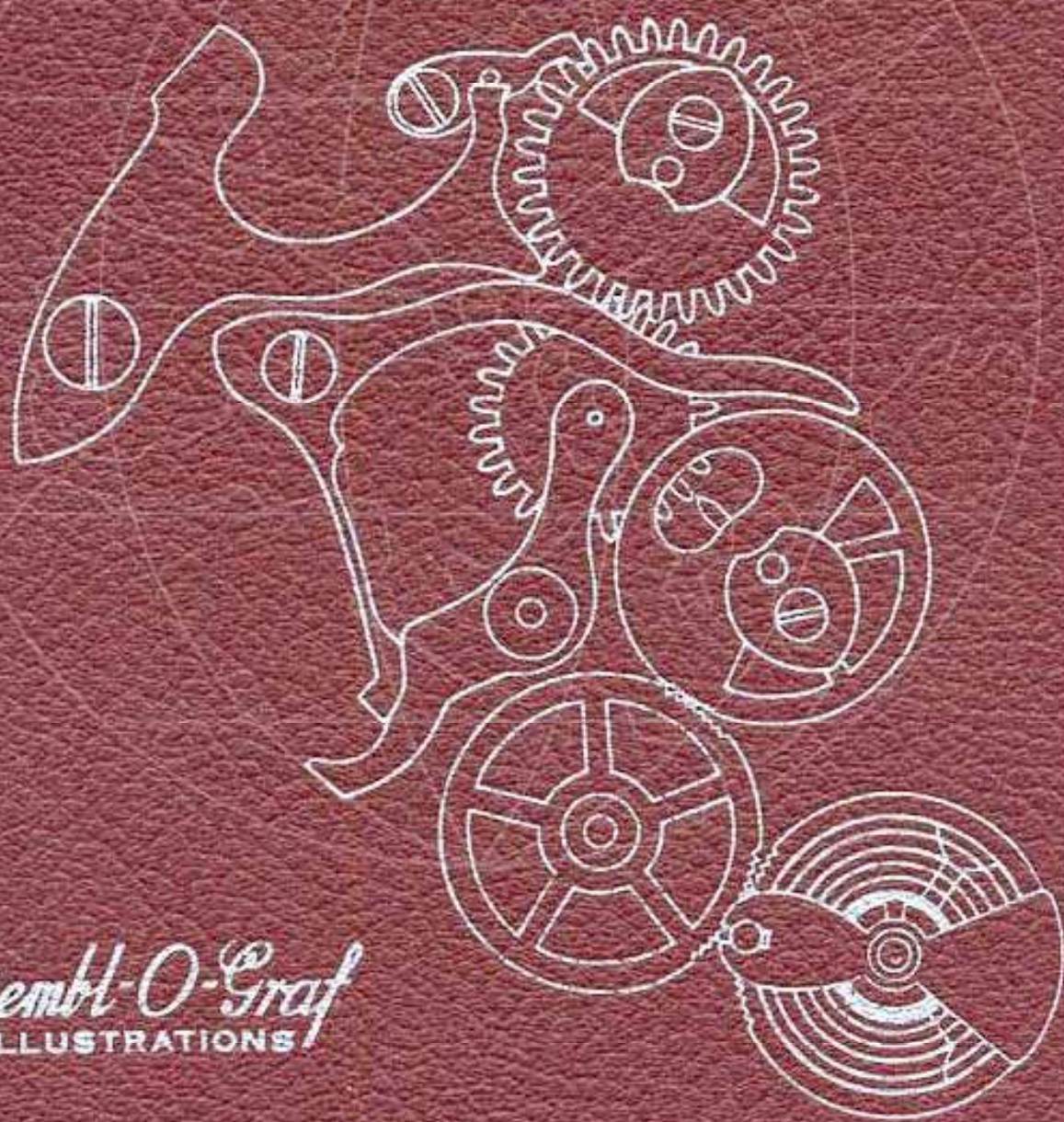

Essembl-O-Graf
ILLUSTRATIONS

IDENTIFICATION OF CHRONOGRAPH



12L

MOVADO

12L

CAL. 90-M
MINUTE REGISTER
CAL. 95-M
MINUTE REGISTER
AND HOUR REGISTER



ESEMBL-O-GRAF

THE WORLD'S FIRST FULLY
ILLUSTRATED TEXT BOOK
ON
CHRONOGRAPH REPAIRING
AND ADJUSTING



BY

William O. Smith, Sr.

PRESIDENT AND TECHNICAL DIRECTOR

AND

William O. Smith, Jr.

CHIEF ENGINEER, RESEARCH LABORATORIES

WESTERN PENNSYLVANIA HOROLOGICAL INSTITUTE, INC.
PITTSBURGH, PENNSYLVANIA

INSTRUCTIONS For use of book

DISASSEMBLY OF THE CHRONOGRAPH MECHANISM:

1. Study the isometric drawing at top of page 1-A. The isometric drawing was made for the following purposes:

- A. It helps to identify the part to be removed.
- B. This drawing aids in pointing out certain locations on the part that are mentioned in the oiling procedure.
- C. The text refers to certain points on the part. These points are shown in the isometric drawing. This should aid you in finding the exact location on the part that is described in the text.
- D. It helps you to determine the shape of the part in case a new part has to be made.
- E. When disassembling the chronograph, each part should be carefully examined as it is removed from the movement. Each part should be checked against the isometric drawings to see that the part is the correct shape and is not broken. Each part should also be checked for any pits of rust, roughness, or burrs and for worn parts which may cause the part not to work properly.

2. At the bottom of the page 1-A is a photograph of a chronograph. In this photograph is the same part painted in black. The part is in the exact location that this part occupies in the watch. Find this location in the watch.

3. Read the disassembly procedure and the hazards in disassembly on page 1 in this book.

4. Remove this part in the same procedure as described in the text.

5. A very important item in disassembling a chronograph is keeping the screws in order, much time will be lost in putting the chronograph together if screws are mixed up. This means you have to hunt for each screw, sometimes trying three or four screws before finding the correct one. It cannot be stressed too strongly that care should be taken so that screws are not mixed up. The system that we advise for beginners, is to replace each individual screw after each part is removed. This naturally eliminates the hazard of mixing up the screws and will save you much time in the end. Do this at least until you become so thoroughly familiar with the chronograph that you no longer feel it is necessary.

6. Continue to follow this procedure throughout the book, and disassemble each part until the last part of the chronograph is removed.

ASSEMBLY OF THE CHRONOGRAPH MECHANISM:

7. When you are ready to assemble the chronograph mechanism, study the isometric drawing on the last part in this book. This drawing should aid you in identifying the part to be assembled and detecting possible defects on the part.

8. At the bottom of this page is a photograph of a chronograph. In this photograph is the same part painted in black. The part is shown in the exact location it occupies in the watch. (Continued on next page)

INSTRUCTIONS (Continued)

9. After you find the correct location for this part in the watch, read the oiling procedure for this part. The oiling procedure for this part is located underneath the isometric drawing. It is best to read the oiling procedure before you put each part in place, as there are certain parts that must be oiled immediately, as it may prove difficult to oil them later.
10. Read the assembly procedure and the hazards in assembling for the last part in this book.
11. Replace the part in its exact location, as shown in photograph, using the procedure as described in the text.
12. Replace the screw that holds this part in place. Of course, the screws should be kept in order as we advised above, but if the screws are not in order or the watch was received with screws mixed up, you will find a screw drawn for each part that requires a screw, at the bottom of the text page.
13. After replacing this part, replace the next part, etc., until the last part is replaced, which will be part No. 1. For replacing each part, use the procedure as described in the text.





(Note: the assembly of the chronograph is exactly the reverse of the disassembly.)

14. After the chronograph mechanism is assembled, read the functions of the different parts in the mechanism. This should help you to understand more fully the purpose of each part and how it works in conjunction with the other parts. It is to your advantage also to read the function before assembling each part, as many mistakes can be prevented when the assembling is done with an understanding of the function.
15. Read the text on adjustment of eccentric studs. This text should be read with reference to the eccentric stud picture. Now adjust each eccentric stud, one at a time, in the watch, as described in the text. Use the picture to find the position of these studs.
16. Study the text on functional results in this book, and check the chronograph mechanism as described in this text.

NOMENCLATURE OF PARTS FOR CHRONOGRAPH MECHANISM

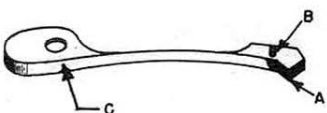
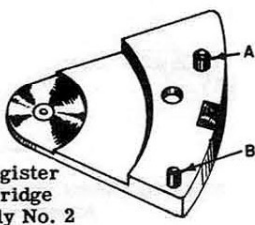
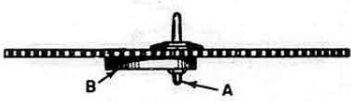
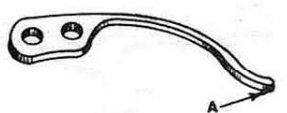
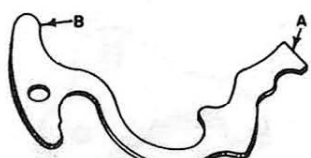
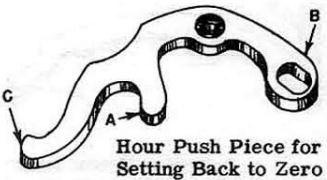
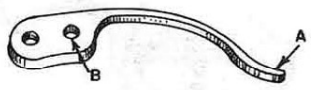
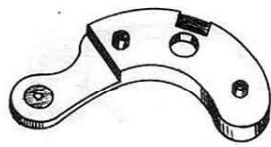

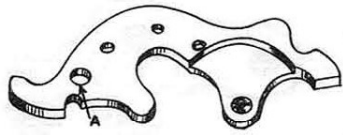

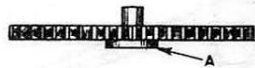
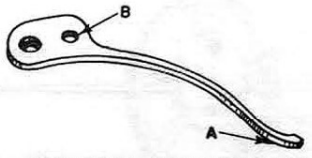
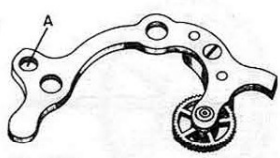

17. After you have become thoroughly familiar with the chronograph mechanism, you can disassemble and assemble the chronograph by using the nomenclature of parts as a guide. This makes it possible for you to use a procedure without going through each page in the book.
18. On each page in this book, the part number and the page number are the same. This makes it convenient for the reader and eliminates any confusion.

NOMENCLATURE OF PARTS FOR CHRONOGRAPH MECHANISM

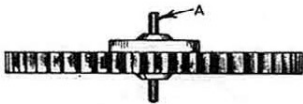
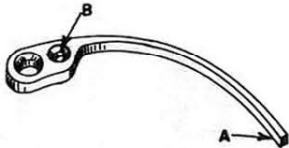
 <p>Hour Register Pawl Assembly No. 1</p>	 <p>Hour Register Wheel Bridge Assembly No. 2</p>	 <p>Hour Register Wheel Assembly No. 3</p>
 <p>Hour Flyback Spring Assembly No. 4</p>	 <p>Hour Flyback Lever Assembly No. 5</p>	 <p>Hour Push Piece for Setting Back to Zero Assembly No. 6</p>
 <p>Hour Pivoted Detent Spring Assembly No. 7</p>	 <p>Hour Pivoted Detent Bridge Assembly No. 8</p>	 <p>Intermediary Hour Wheel Assembly No. 9</p>
 <p>Hour Pivoted Detent Assembly No. 10</p>	 <p>Intermediary Driving Pinion Assembly No. 11</p>	 <p>Wheel over Fourth Wheel Assembly No. 12</p>
 <p>Chronograph Pivoted Detent Spring Assembly No. 13</p>	 <p>Chronograph Pivoted Detent Assembly No. 14</p>	

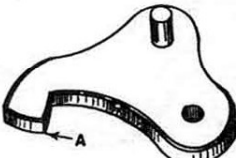
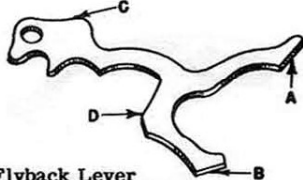

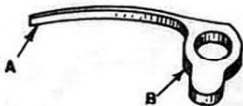
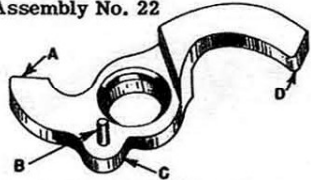
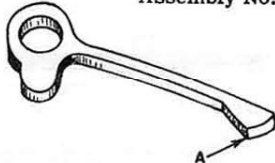
Continued on the next page

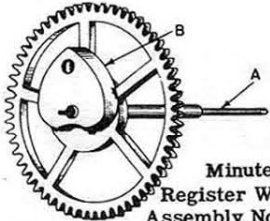
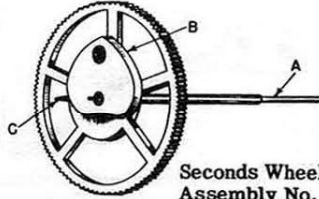
NOMENCLATURE OF PARTS FOR CHRONOGRAPH MECHANISM

 <p>Intermediary Wheel Assembly No. 14-B</p>	 <p>Actuating Detent Lever Spring Assembly No. 15</p>	 <p>Flyback Lever Spring Assembly No. 16</p>
 <p>Actuating Detent Lever Assembly No. 17</p>	 <p>Joint Hook Assembly No. 18</p>	 <p>Flyback Lever Assembly No. 19</p>
 <p>Flyback Connecting Lever Assembly No. 20</p>	 <p>Brake Lever Spring Assembly No. 21</p>	 <p>Brake Lever Assembly No. 22</p>
 <p>Castle Wheel Pawl Assembly No. 23</p>	 <p>Castle Wheel Assembly No. 24</p>	 <p>Seconds Wheel and Minute Register Wheel Bridge Assembly No. 25</p>
 <p>Minute Register Wheel Assembly No. 26</p>		 <p>Seconds Wheel Assembly No. 27</p>

Continued on the next page

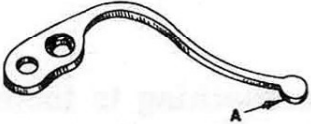
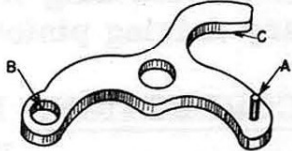
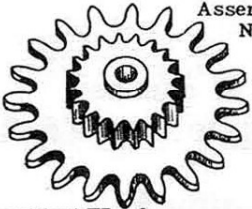
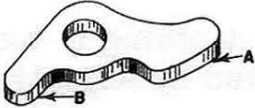
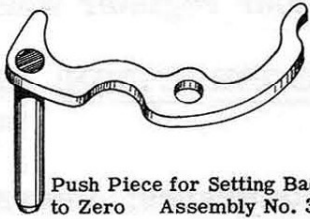
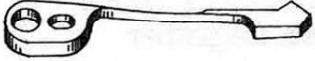
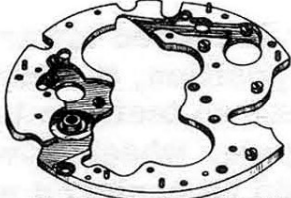
NOMENCLATURE OF PARTS FOR CHRONOGRAPH MECHANISM

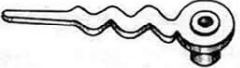
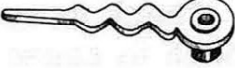
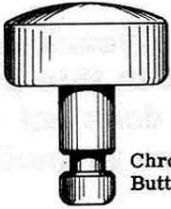
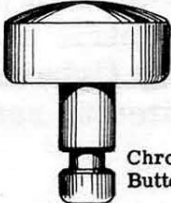
 <p>Seconds Wheel Tension Spring Assembly No. 28</p>	 <p>Intermittent Lever Spring Assembly No. 29</p>	 <p>Intermittent Lever Assembly No. 30</p>
 <p>Intermittent Wheel Assembly No. 31</p>	 <p>Intermittent Connecting Lever Assembly No. 32</p>	 <p>Push Piece for Setting Back to Zero Assembly No. 33</p>
 <p>Minute Register Pawl Assembly No. 34</p>	 <p>Assembly Plate Assembly No. 35</p>	 <p>Sweep Second Hand</p>
 <p>Minute Register Hand</p>	 <p>Hour Register Hand</p>	 <p>Chronograph Button</p>
 <p>Chronograph Button</p>		

ADJUSTING ECCENTRIC STUDS --- THINGS TO CHECK --- DIAL SIDE

REPLACING AND ADJUSTING THE INTERMEDIARY DRIVING PINION

NOTICE

Be sure the eccentric studs on the train side of the chronograph are properly adjusted before proceeding with the following instructions.

As explained on page 1 and page 11, the intermediary driving pinion should not as yet have been replaced. The pinion should now be replaced, following the instructions in the next paragraph.

REPLACING THE INTERMEDIARY DRIVING PINION

Replace the intermediary driving pinion, Part no. 11, in the position shown on page 11-A. Place the pinion on the post of the minute register wheel, with the larger diameter of the tapered hole in pinion down. (Caution: Press the pinion down on the post very lightly, as the pinion must yet be turned on the post to adjust it.)

1. Check the depthing of the intermediary hour wheel with the intermediary driving pinion.

CORRECTION: If the depthing is incorrect, it can be corrected by adjusting eccentric stud ES-1. Adjust the depthing of this wheel and pinion to the same depthing of the wheels and pinions in a regular watch.

IMPORTANT

IMPORTANT

IMPORTANT

When adjusting the depthing of the intermediary wheel with the intermediary driving pinion, the eccentric stud ES-1 should be in a position, so that when this stud is turned clockwise, the depth will become more shallow, and when the stud is turned counter-clockwise, the depthing becomes deeper.)

2. Check the depthing of the intermediary hour wheel teeth with the hour register wheel teeth.

CORRECTION: If this depthing is incorrect, it can be corrected by adjusting eccentric stud ES-2. This depthing should be slightly shallow.

NOTE: Due to the construction of the chronograph, it is necessary to adjust eccentric stud ES-3 before adjusting Part No. 1. For this reason, the instructions for adjusting eccentric stud ES-3, will be found on page 1.

ADJUSTING INTERMEDIARY DRIVING PINION

3. Push the push piece to return all wheels to zero. While releasing the push piece very slowly, check to see that the teeth of the intermediary hour wheel engage with the hour register wheel, without turning the latter wheel counter-clockwise.

CORRECTION: If necessary, adjust the pinion by turning it very slightly clockwise or counter-clockwise on the post of the minute register wheel to such a position so that the intermediary hour wheel can engage with the hour register wheel without turning the latter wheel counter-clockwise. (When turning the pinion on the post, hold the minute register wheel stationary. Otherwise, the wheel and the pinion may turn as a unit.) When the pinion is properly adjusted, support the lower pivot of the minute register wheel and press the pinion down on the post until the teeth of the intermediary hour wheel are centered between the top and bottom of the pinion.

REFERENCE: Hour register wheel is Assembly 3.
Hour flyback lever is Assembly 5.
Intermediary hour wheel is Assembly 9.
Intermediary driving pinion is Assembly 11.

ADJUSTING ECCENTRIC STUDS

DO NOT REMOVE THESE STUDS
DIAL SIDE

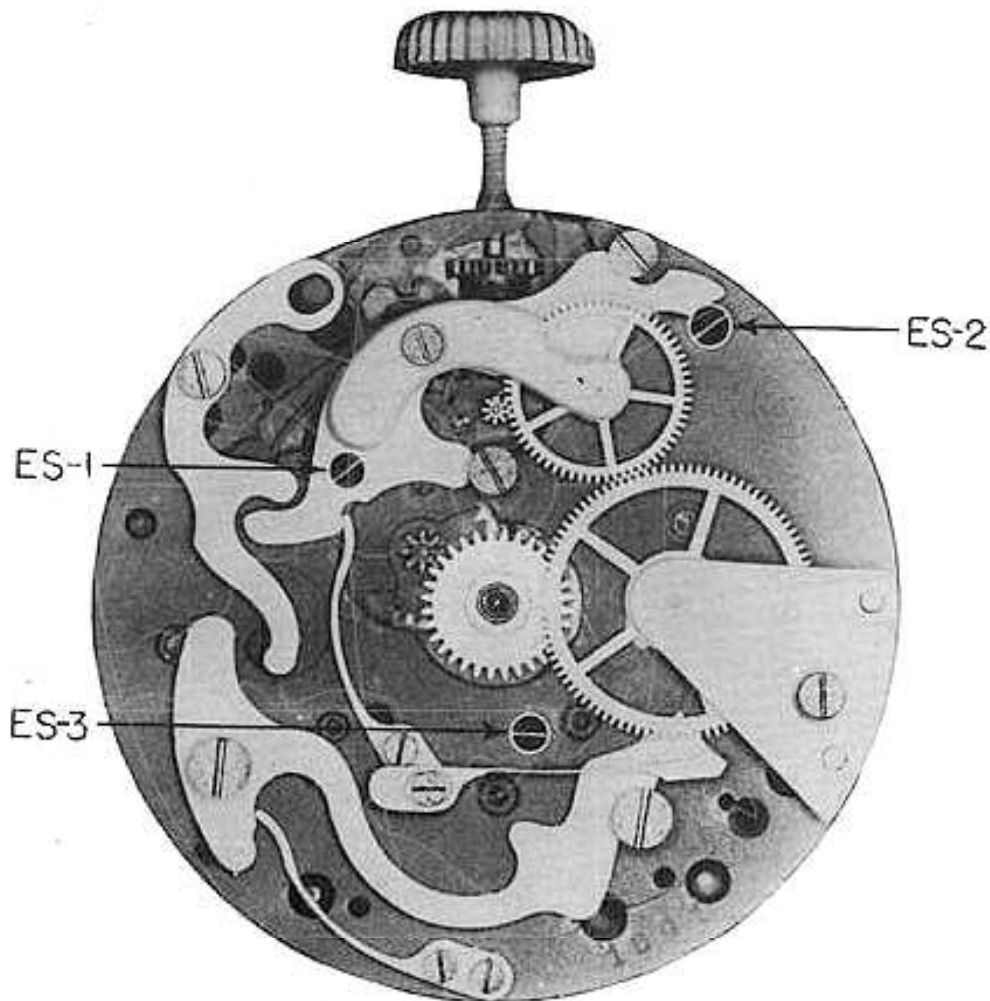

CAUTION

In disassembling or assembling chronograph it is a good policy not to turn eccentric studs. These eccentric studs are used to adjust one part to another and naturally in turning these studs you will lose the desired adjustment of the chronograph mechanism which will cause the chronograph to function incorrectly. Another reason for not turning these studs unless it is necessary is that they soon become loose and will not hold the desired adjustment.

ADJUSTING ECCENTRIC STUDS - THINGS TO CHECK

TRAIN SIDE

Listed below are a number of depthings and adjustments controlled by eccentric studs:

1. Check depthing of intermittent wheel teeth with seconds wheel dart tooth.

CORRECTION: If the depthing is incorrect, it can be corrected by adjusting eccentric stud ES-4.

REFERENCE: Seconds wheel dart tooth is Assembly 27C.
Intermittent wheel is Assembly 31.

2. Check the depthing of the intermittent wheel with the minute register wheel.

CORRECTION: If this depthing is incorrect, it can be corrected by adjusting eccentric stud ES-5.

REFERENCE: Intermittent wheel is Assembly 31.
Minute register wheel is Assembly 26.

3. With the flyback lever holding the minute register wheel at a zero position, check to see that end "A" of minute register pawl is setting exactly between the center of two teeth on the minute register wheel.

CORRECTION: If the pawl is not setting exactly between two teeth on the minute register wheel, it can be corrected by adjusting eccentric stud ES-6.

REFERENCE: Minute register wheel is Assembly 26.
Minute register pawl is Assembly 34.

4. Check depthing of intermediary wheel with wheel over fourth wheel.

CORRECTION: If this depthing is incorrect, it can be corrected by adjusting eccentric stud ES-7.

REFERENCE: Wheel over fourth wheel is Assembly 12.
Intermediary wheel is shown on Page 14C.

5. Check depthing of the seconds wheel with the intermediary wheel.

CORRECTION: If this depthing is incorrect, it can be corrected by adjusting eccentric stud ES-8.

REFERENCE: Seconds wheel is Assembly 27.
Intermediary wheel is shown on Page 14C.

ADJUSTING ECCENTRIC STUDS

DO NOT REMOVE THESE STUDS
TRAIN SIDE

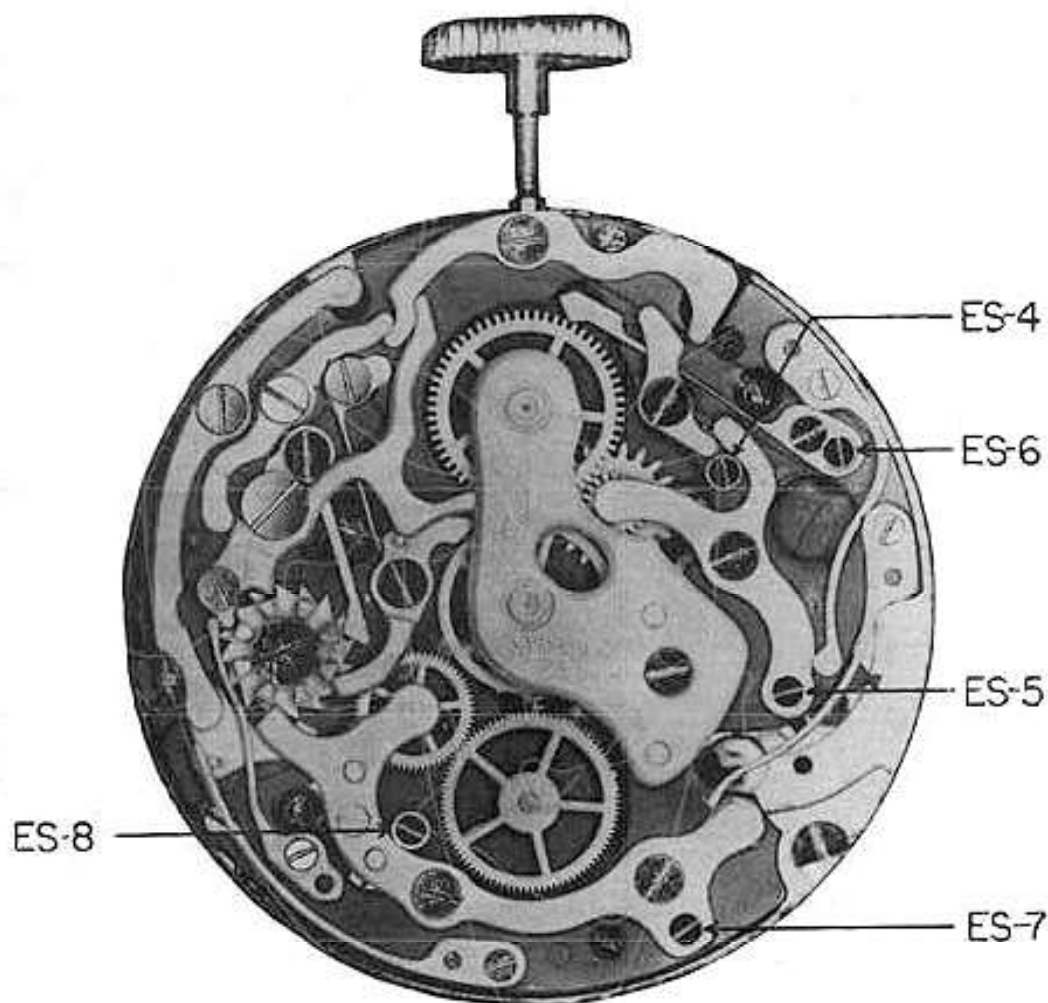

CAUTION

In disassembling or assembling chronograph it is a good policy not to turn eccentric studs. These eccentric studs are used to adjust one part to another and naturally in turning these studs you will lose the desired adjustment of the chronograph mechanism which will cause the chronograph to function incorrectly. Another reason for not turning these studs unless it is necessary is that they soon become loose and will not hold the desired adjustment.

PART NO. 1

A. DISASSEMBLY PROCEDURE OF HOUR REGISTER PAWL:

The pawl is held in place by a fillister head screw, FS-1. Before removing screw, place a screwdriver against surface "C" on the pawl. This will brace the pawl so that when removing the screw, the head of screw will not twist the pawl and bend it. After screw is removed, the hour register pawl will be free, and can be lifted out of place.

(The shape of screw for this part is shown at the bottom of the page.)

B. ASSEMBLY PROCEDURE OF HOUR REGISTER PAWL:

Place pawl in its proper position, as shown in photograph. The hour register pawl fits over the hour pivoted detent spring, Assembly No. 7. When replacing this pawl, place the pin "B" down, and on the outside edge of hour flyback lever. After the pawl is set correctly, replace fillister head screw FS-1 that holds this pawl in position.

ADJUSTING ECCENTRIC STUD ES-3

With the flyback lever holding the hour register wheel at a zero position, check to see that hour register wheel is not held absolutely stationary, but is permitted to turn slightly.

CORRECTION: The amount the hour register flyback lever permits the hour register wheel to turn is controlled by adjusting eccentric stud ES-3. (The position of this stud is shown on photograph.)

NOTE: In some Movado chronographs, the manufacturers have replaced the eccentric stud ES-3 with a properly shaped screw. When a screw is found in this position, and the hour flyback lever is not properly adjusted, it will be necessary to reduce the diameter of the screwhead to decrease the turning of the hour register wheel, or to shorten the flyback lever to permit the wheel to turn slightly.

ADJUSTMENT OF HOUR REGISTER PAWL:

With the flyback lever holding the hour register wheel at a zero position, loosen fillister head screw FS-1 and adjust the pawl to such a position, that with the pawl centered between two teeth, the wheel can be turned with a fine broach exactly the same amount clockwise or counter-clockwise. If the hour flyback lever permits excessive turning of the wheel by a broach, so that point of pawl passes equally over a tooth on either side, adjust eccentric stud ES-3.

IMPORTANT NOTICE

Intermediary driving pinion is the only part that should not, as yet, have been assembled. Do not replace this pinion until after the eccentric studs on the train side of the watch have been adjusted. The reason this pinion should not be replaced until after the eccentric studs on the train side of the watch are adjusted, is because the adjustment of the pinion on the post cannot be accurately made until the adjustments on the train side of the watch are correct. After the adjustments on the train side of the watch are set correctly, the pinion, Part No. 11, can then be replaced. The procedure for replacing this pinion, along with the method of adjusting this pinion properly on the post, is explained in the text on adjusting the eccentric studs, dial side.

C. FUNCTION OF HOUR REGISTER PAWL:

The function of the pawl is to hold the hour register wheel stationary until the intermediary hour wheel engages with this wheel.

REFERENCE: Hour flyback lever is Assembly 5.
Hour register wheel is Assembly 3.
Intermediary hour wheel is Assembly 9.
Intermediary driving pinion is Assembly 11.

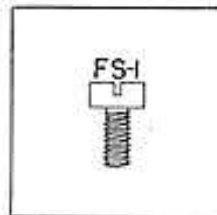

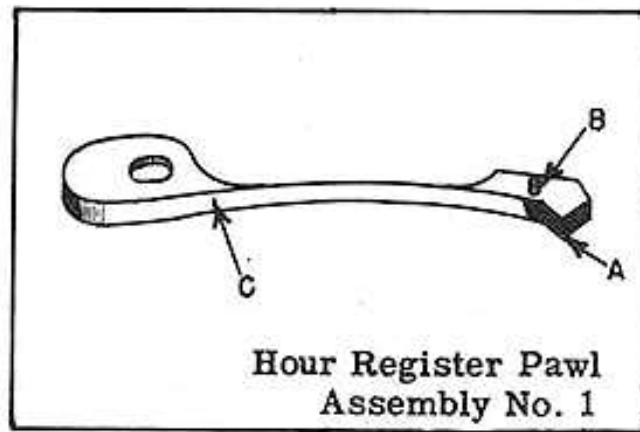

OILING

The hour register pawl should not be oiled.

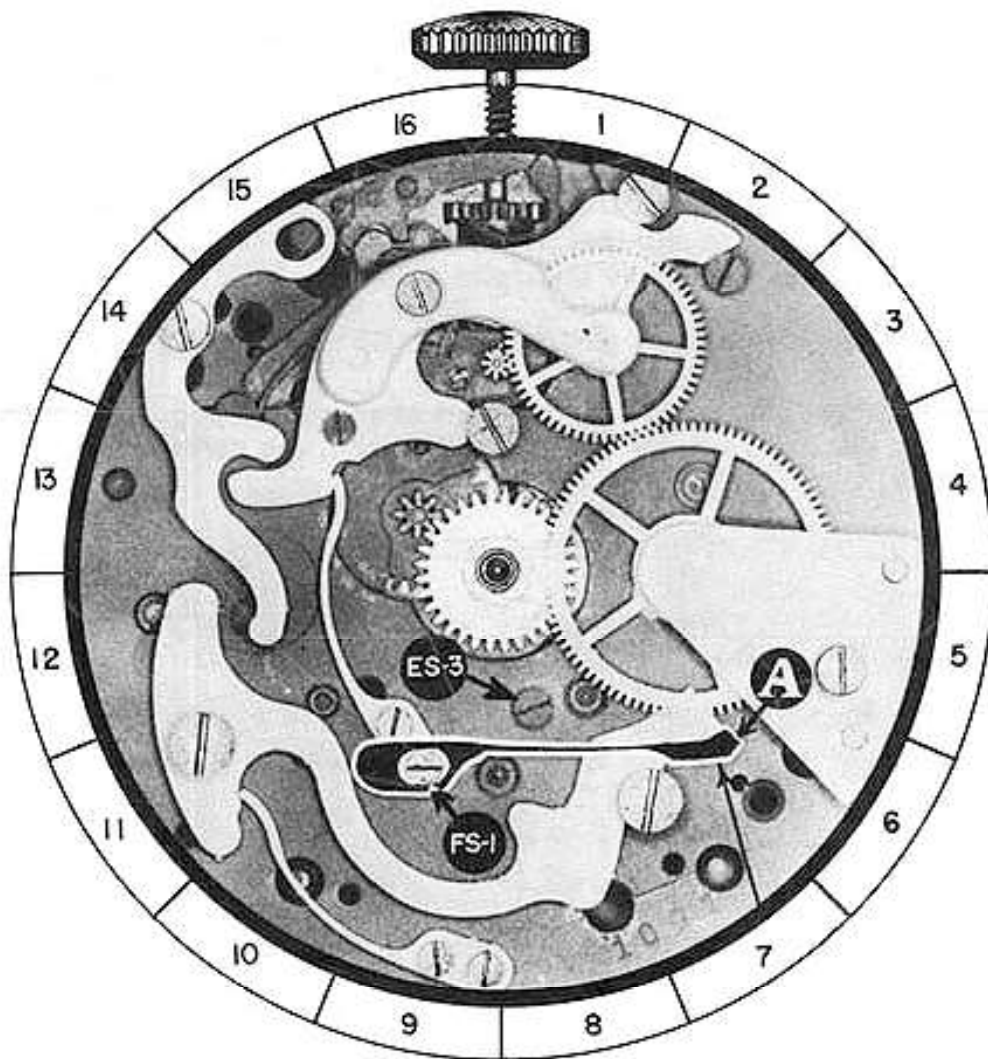

1A

A. DISASSEMBLY PROCEDURE OF HOUR REGISTER WHEEL BRIDGE:

This bridge is held in place by a fillister head screw FS-2. After screw is removed, take a small finely-sharpened screwdriver and slide screwdriver under bridge. You will notice a notch cut in the bridge to receive the screwdriver. After sliding the screwdriver under the bridge, the bridge will be free on plate and can be lifted out of place.

(The shape of screw for this part is shown at bottom of page)

B. HAZARDS IN DISASSEMBLY OF HOUR REGISTER WHEEL BRIDGE:

When removing the bridge, care should be taken to keep bridge as level as possible to eliminate any hazard of bending or breaking the hour register wheel pivot.

C. ASSEMBLY PROCEDURE OF HOUR REGISTER WHEEL BRIDGE:

Place the pivot hole in bridge over pivot on hour register wheel. Now place the bridge on plate with steady pins "A" and "B" on bridge in their proper holes in plate. Now press bridge down to proper place and replace fillister head screw FS-2.

At this time the hour register wheel should be checked to see that this wheel is free and that the pivots are not binding in the pivot holes. Also, check to see that this wheel has endshake, of course, it should not have excessive endshake.

D. HAZARDS IN ASSEMBLY OF HOUR REGISTER WHEEL BRIDGE.

If the hour register wheel pivot is not entering the pivot hole when pressing the bridge down to its proper place, the pivot may bend or break.

E. FUNCTION OF HOUR REGISTER WHEEL BRIDGE:

The hour register wheel bridge holds the hour register wheel upright and in position so that this wheel can function properly.

REFERENCE: Hour register wheel is Assembly 3.

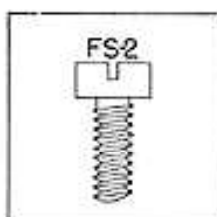

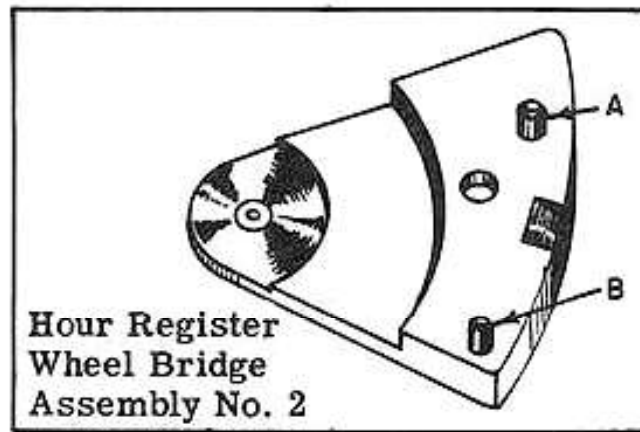

OILING

The pivot in this bridge should be oiled as you would properly oil a train pivot in a watch.

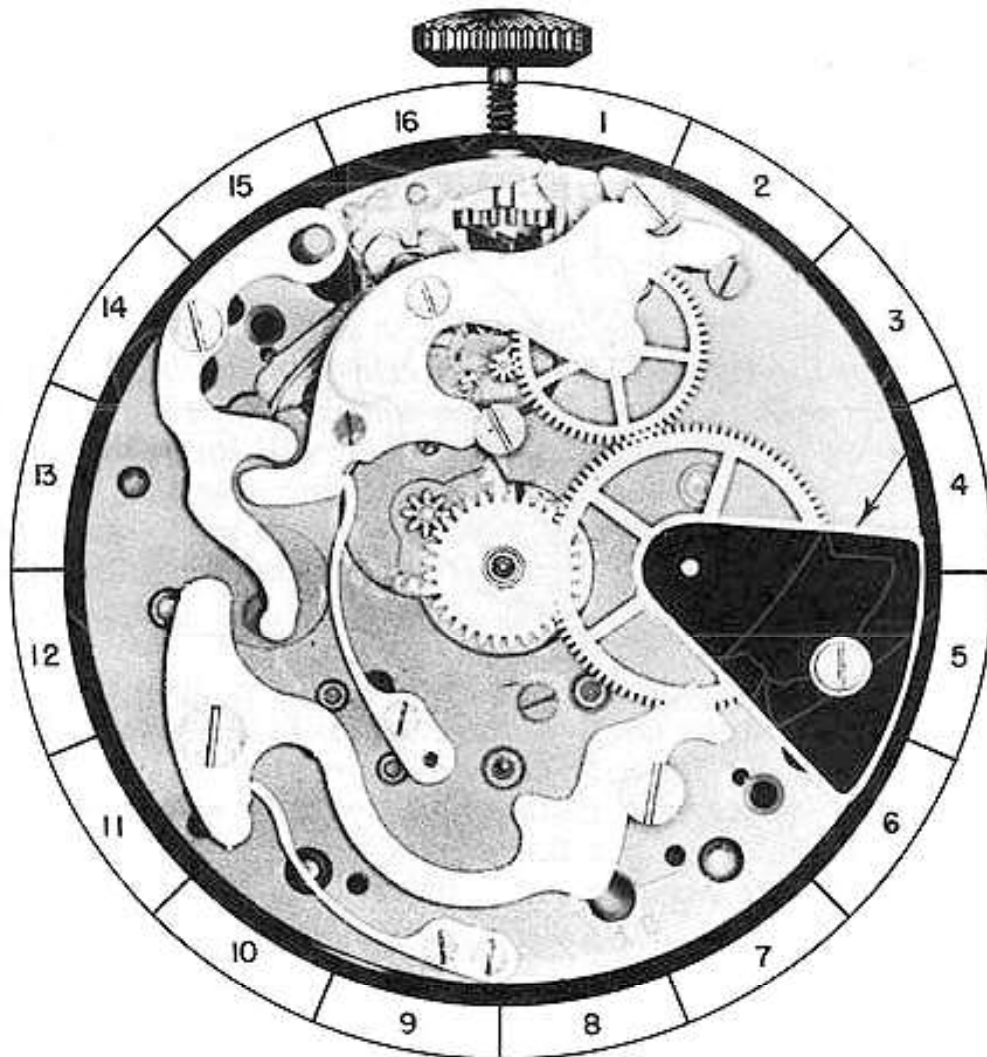

2-A

A. DISASSEMBLY PROCEDURE OF HOUR REGISTER WHEEL:

To remove the hour register wheel, simply lift it out of place. After the hour register wheel is removed, the hour wheel shown as "C" in the photograph may be lifted out of place.

B. ASSEMBLY PROCEDURE OF HOUR REGISTER WHEEL:

Before replacing the hour register wheel, replace the hour wheel shown as "C" in the photograph. Then place the hour register wheel in position as shown in the photograph, with the short pivot "A" down in the pivot hole in the plate.

C. FUNCTION OF HOUR REGISTER WHEEL:

The function of the hour register wheel is to register the hours that the chronograph mechanism has been in operation. This is done by a hand being attached to the long pivot on the hour register wheel registering the hours on the dial. The heart "B" on the hour register wheel is used for returning the wheel to zero.

REMARKS:

Generally speaking, the returning to zero function is performed by the flyback lever contacting a heart on the wheel. The heart is set eccentric on the wheel. When the flat end of the flyback lever contacts the heart, it will force the heart to turn until the flat end of the flyback lever sets across the two lobes at the top of the heart. With the pressure equalized at these two lobes, it will turn no further, and this is what is commonly known as a zero position.

In the case of the hour register wheel, the hour flyback lever does not return the hour register wheel to an exact zero position. This is the function of the hour register pawl. When the hour flyback lever contacts the heart, it will turn the heart and wheel to a position close enough to zero, that will permit the hour register pawl, by centering itself between two teeth, to return the hour register wheel to an exact zero position.

REFERENCE: Hour flyback lever is Assembly 5.

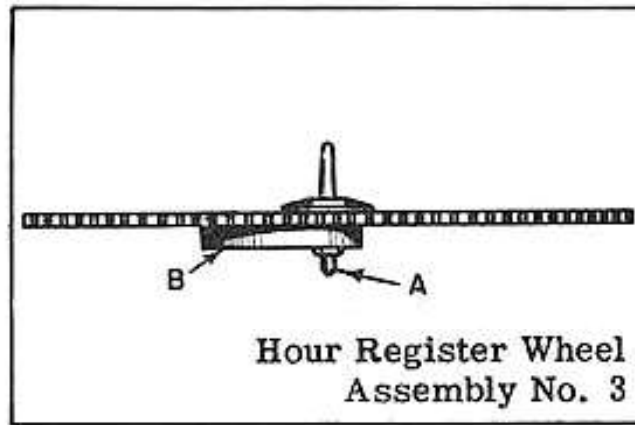

OILING

The bottom pivot on hour register wheel should be oiled before replacing this part in watch. The top pivot is oiled after bridge for this part is placed in watch.

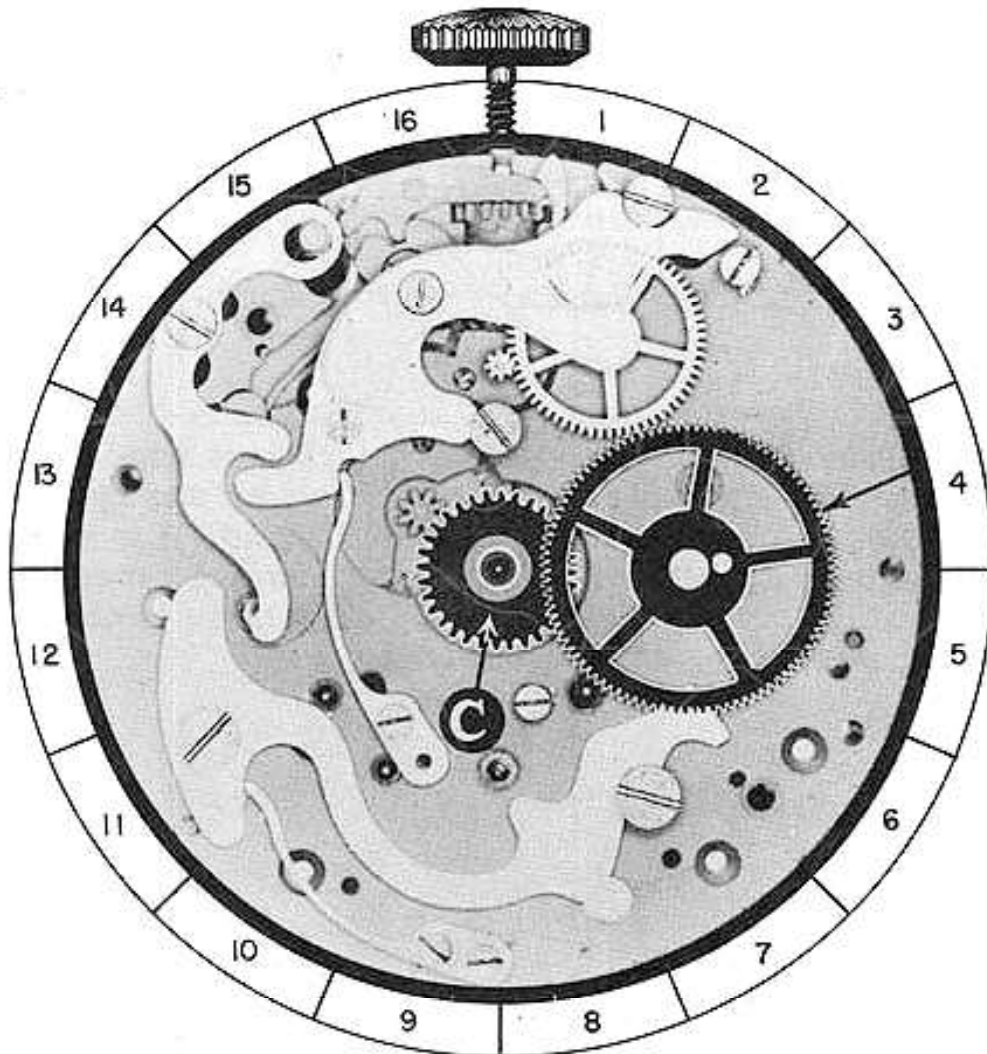

3-A

A. DISASSEMBLY PROCEDURE OF HOUR FLYBACK LEVER SPRING:

The hour flyback lever spring is held in place by fillister head screws FS-3 and FS-4. When these screws are removed, the flyback lever spring will be free on the plate, and can be lifted out of place.

(The shape of screws for this part is shown at bottom of page)

B. ASSEMBLY PROCEDURE OF HOUR FLYBACK LEVER SPRING:

Place this spring in its proper position on the plate, as shown in the photograph. Now replace the two fillister head screws FS-3 and FS-4 that hold this spring in place.

C. FUNCTION OF HOUR FLYBACK LEVER SPRING:

The function of this spring is to return the hour flyback lever to its original position and hold it in this position each time it is pushed toward the center of the watch and released.

REFERENCE: Hour flyback lever is Assembly 5.

REMARKS:

While assembling the chronograph, each part should be checked one at a time thoroughly for rust or damage. This may save you a great deal of time in the end. It is also advisable to check each part with the isometric drawing to see that the part is shaped correctly and there is nothing broken or missing on the part.

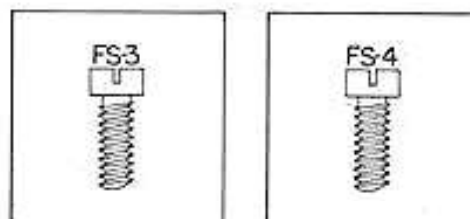

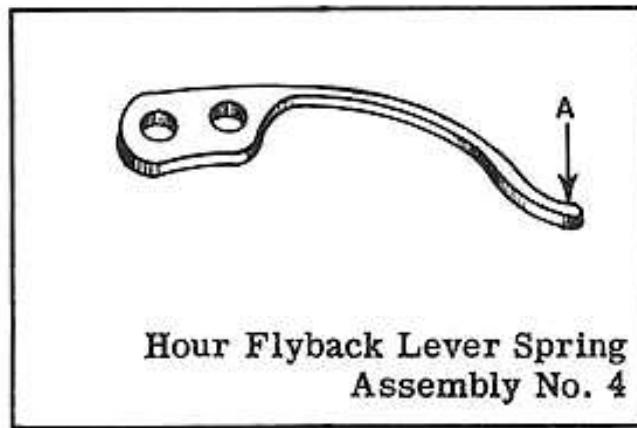

OILING

End "A" on flyback lever spring should be slightly moistened with oil at point of contact with flyback lever.

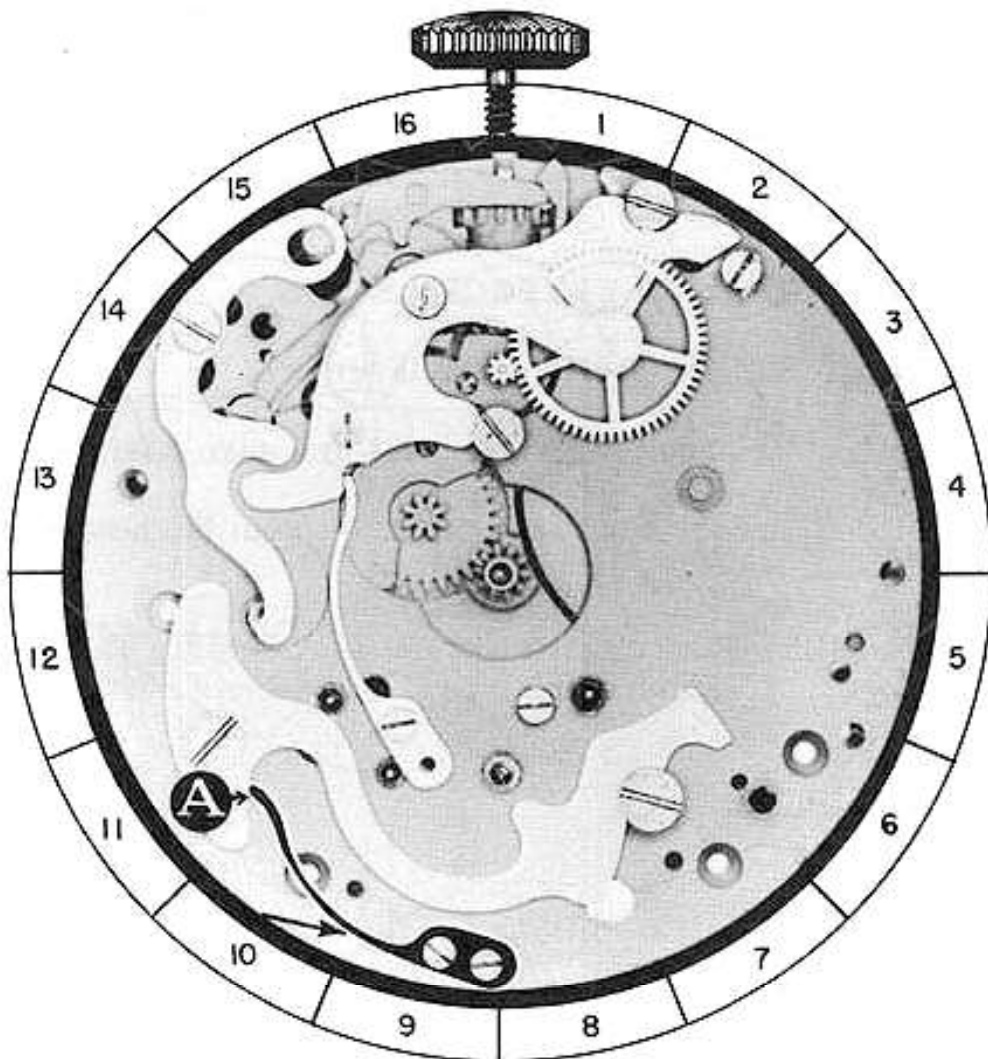

4-A

A. DISASSEMBLY PROCEDURE OF HOUR FLYBACK LEVER:

The hour flyback lever is held in place by shouldered screws SS-1 and SS-2. When these screws are removed, the hour flyback lever will be free on the plate, and can be lifted out of place.

(The shape of screws for this part is shown at bottom of page)

B. ASSEMBLY PROCEDURE OF HOUR FLYBACK LEVER:

Before replacing the hour flyback lever, check to see that end "A" is highly polished to reduce friction between flyback lever and hour register heart. To polish this surface, use diamontine on a hard wood block.

To replace the hour flyback lever, place this lever in its proper position on the plate, as shown in the photograph. Now, replace shouldered screws SS-1 and SS-2. These screws are identical in shape, size, and thread. After these screws are replaced, check to see that the hour flyback lever pivots freely under the heads of these screws.

C. FUNCTION OF HOUR FLYBACK LEVER:

The functions of the hour flyback lever are:

1. It returns the hour register wheel to a zero position.
2. It disengages the hour register pawl from the hour register wheel.

REFERENCE: Hour register wheel is Assembly 3.
Hour register pawl is Assembly 1.

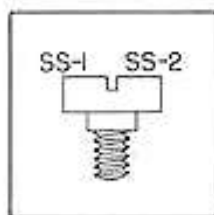

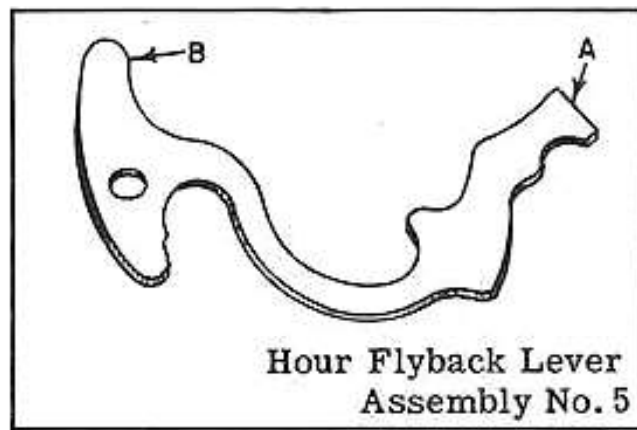

OILING

These points on hour flyback lever should be slightly moistened with oil:

1. The shouldered screw that the hour flyback lever pivots on.
2. End "B" that contacts push piece for setting back to zero.

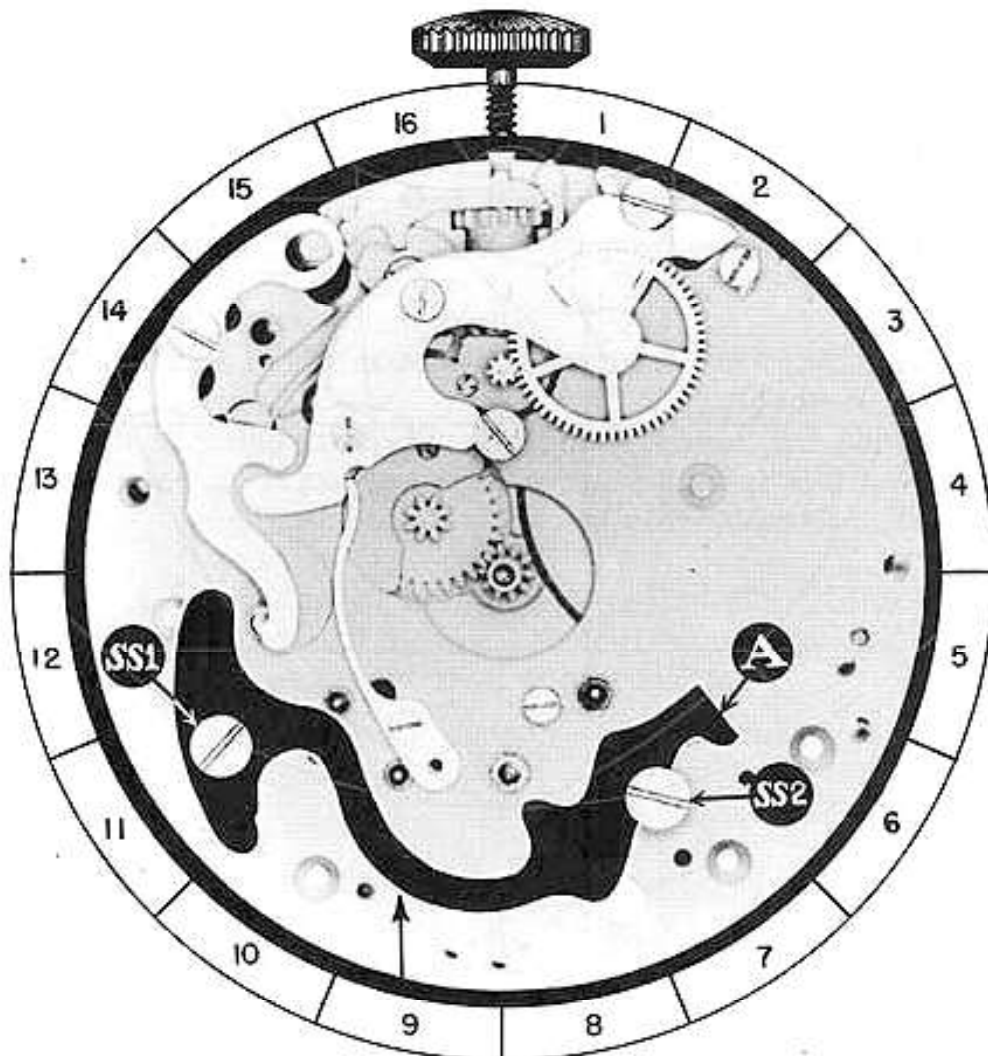

5-A

A. DISASSEMBLY PROCEDURE OF HOUR PUSH PIECE FOR SETTING BACK TO ZERO:

The push piece is held in place by a shouldered screw SS-3. When this screw is removed, push piece will be free on plate and can be lifted out of place.

(The shape of screw for this part is shown at bottom of page)

B. ASSEMBLY PROCEDURE OF HOUR PUSH PIECE FOR SETTING BACK TO ZERO:

Place hour push piece in its proper position on plate, with hole "B" on push piece over stud, as shown on photograph. Now replace shouldered screw SS-3 that holds push piece in its proper position. After screw is replaced, check to see that push piece pivots freely under head of this screw.

C. FUNCTION OF THE HOUR PUSH PIECE FOR SETTING BACK TO ZERO:

The functions of the hour push piece for setting back to zero are:

1. It disengages the intermediary hour wheel from the hour register wheel.
2. It forces the hour flyback towards the center of the watch, causing the flyback lever to contact heart on hour register wheel, returning this wheel to a zero position.

REFERENCE: Hour register wheel is Assembly 3.
Hour flyback lever is Assembly 5.
Intermediary hour wheel is Assembly 9.

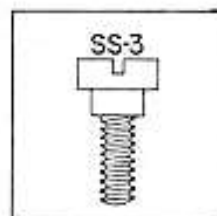

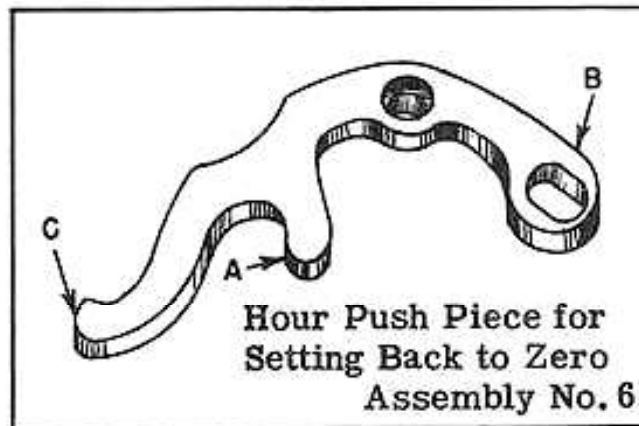

OILING

These points on this part should be slightly moistened with oil:

1. The shoulder of screw push piece pivots on.
2. End "A" at point of contact with hour pivoted detent.
3. The inside surface of hole "B".

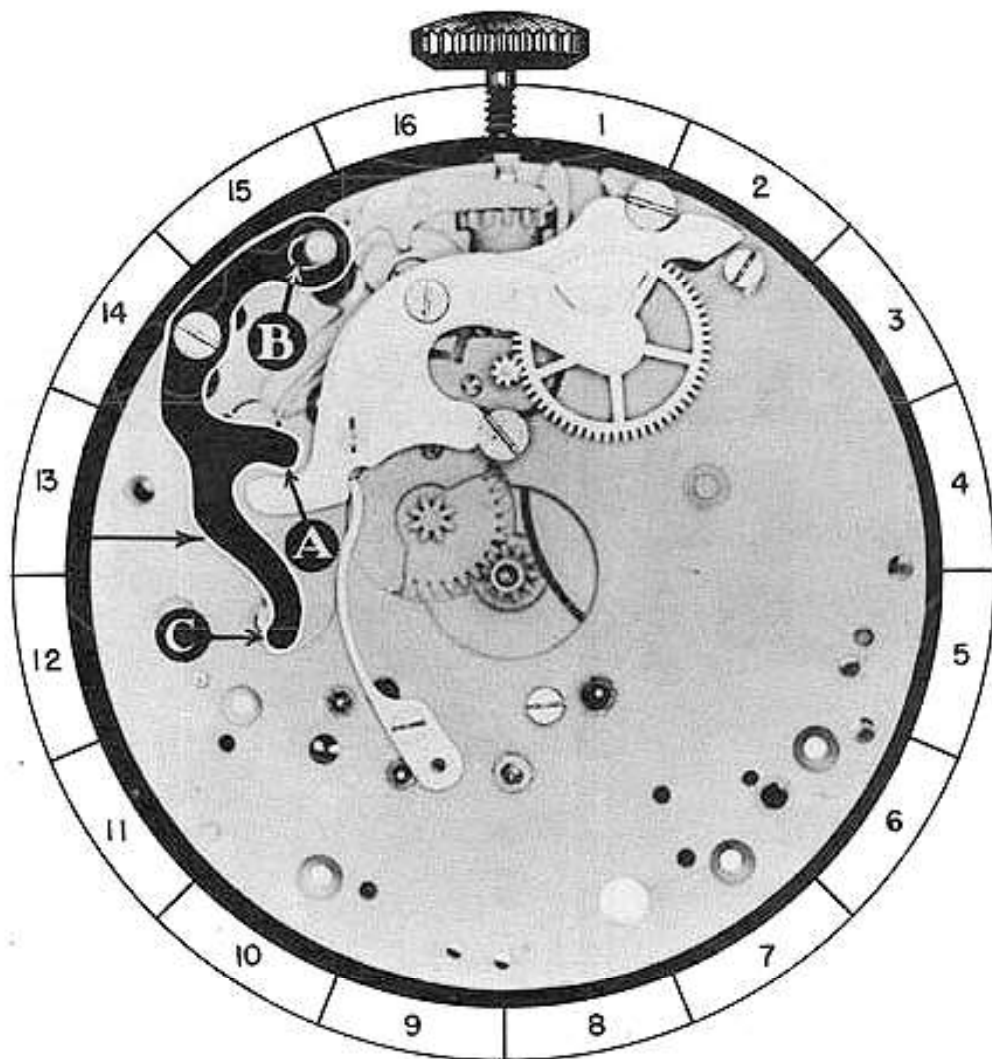

6-A

A. DISASSEMBLY PROCEDURE OF HOUR PIVOTED DETENT SPRING:

This spring is held in place by a fillister head screw FS-5. When this screw is removed, this spring will be free on the plate and can be lifted out of place.

(The shape of screw for this part is shown at bottom of page)

B. ASSEMBLY PROCEDURE OF HOUR PIVOTED DETENT SPRING:

Place the spring in its proper position on plate, as shown in photograph. Replace fillister head screw FS-5 that holds this spring in place. This screw fits in hole "B" in hour pivoted detent spring.

The other screw that holds hour pivoted detent spring in place will not be replaced until later, as this screw also holds the hour register pawl in place.

REFERENCE: Hour register pawl is Assembly 1.

C. FUNCTION OF HOUR PIVOTED DETENT SPRING:

The function of the hour pivoted detent spring is to hold a tension on the hour pivoted detent, keeping the intermediary hour wheel engaged with the hour register wheel.

REFERENCE: Hour pivoted detent is Assembly 10.
Intermediary hour wheel is Assembly 9.
Hour register wheel is Assembly 3.

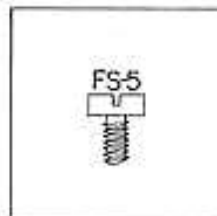

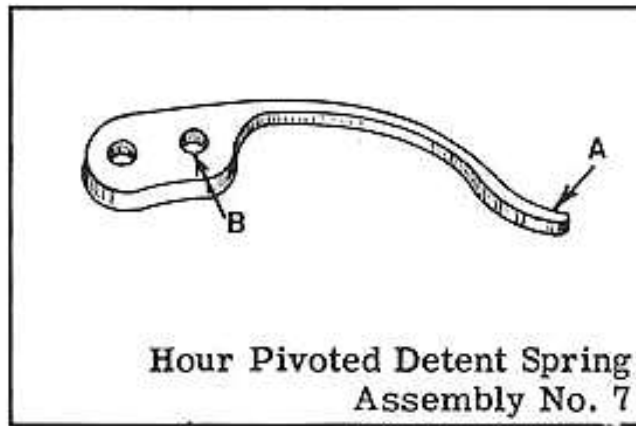

OILING

End "A" on hour pivoted detent spring should be slightly moistened with oil at point of contact with hour pivoted detent.

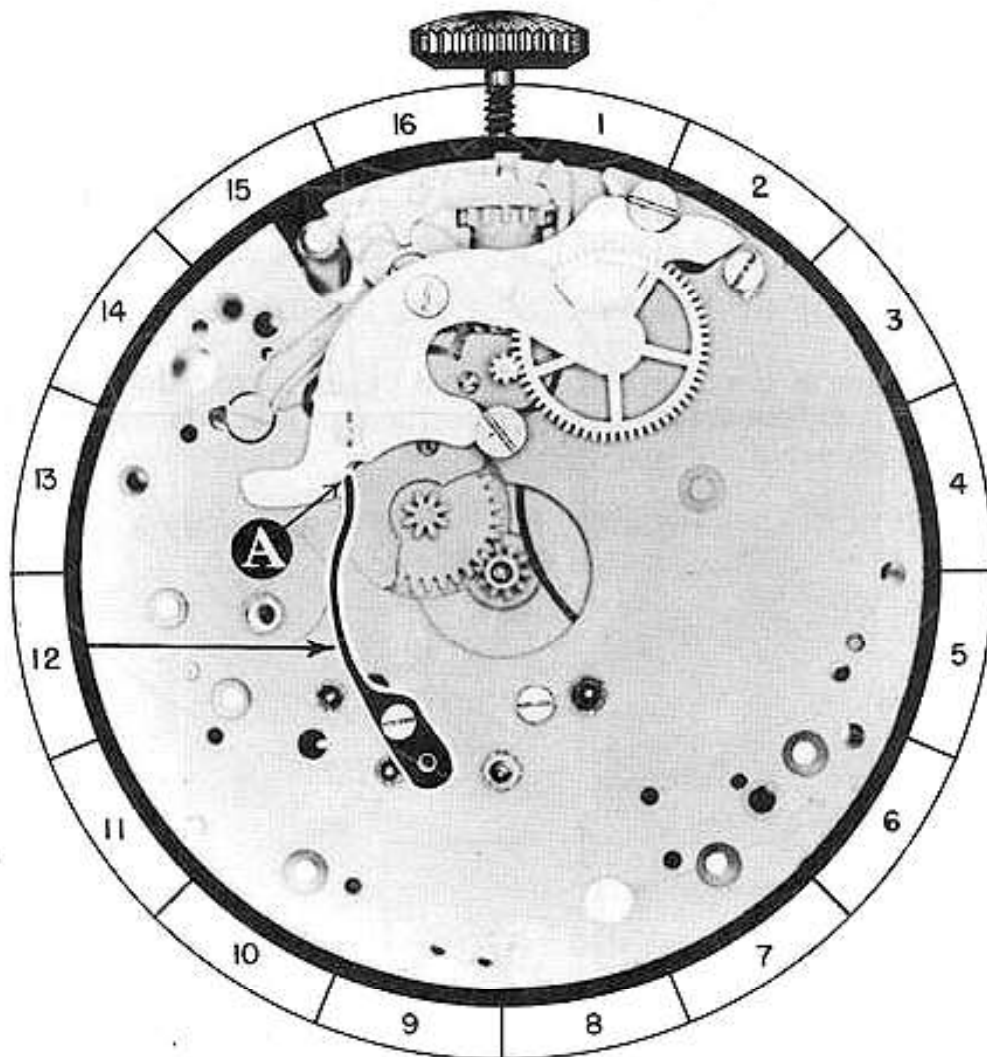

A. DISASSEMBLY PROCEDURE OF HOUR PIVOTED DETENT BRIDGE:

This bridge is held in place by fillister head screw FS-6 and steady pins. When this screw is removed, slide a finely-sharpened screwdriver under the notch in bridge, This will loosen the bridge from the chronograph pivoted detent, freeing it so that the bridge can be lifted out of place.

(The shape of screw for this part is shown at bottom of page.)

B. HAZARDS IN DISASSEMBLY OF HOUR PIVOTED DETENT BRIDGE:

When sliding a screwdriver under the bridge, hold finger over the bridge so that the bridge cannot jump out of place and become lost.

C. ASSEMBLY PROCEDURE OF HOUR PIVOTED DETENT BRIDGE:

Before replacing this bridge, check the pivot hole in the bridge to see that there are no burrs at this location. Now place the bridge in its proper position on the pivoted detent with the steady pins in proper holes. Make sure that the intermediary hour wheel pivot is entering the pivot hole in the bridge. Now press the bridge down in proper place with back of tweezers, and replace fillister head screw FS-6. At this time, check the intermediary hour wheel to see that it pivots freely and has proper endshake.

D. FUNCTION OF HOUR PIVOTED DETENT BRIDGE:

The function of the hour pivoted detent bridge is to hold the intermediary hour wheel in its proper position so that this wheel will function properly.

REFERENCE: Intermediary hour wheel is Assembly 9.
Hour pivoted detent is Assembly 10.

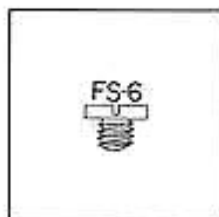

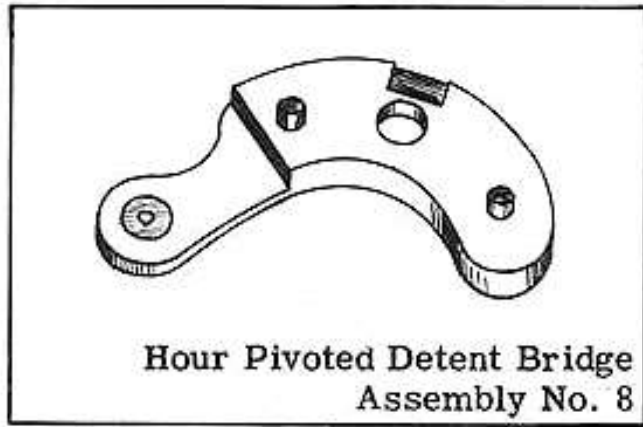

Hour Pivoted Detent Bridge
Assembly No. 8

OILING

The pivot in bushing in this bridge should be oiled as you would properly oil a train pivot in a watch.

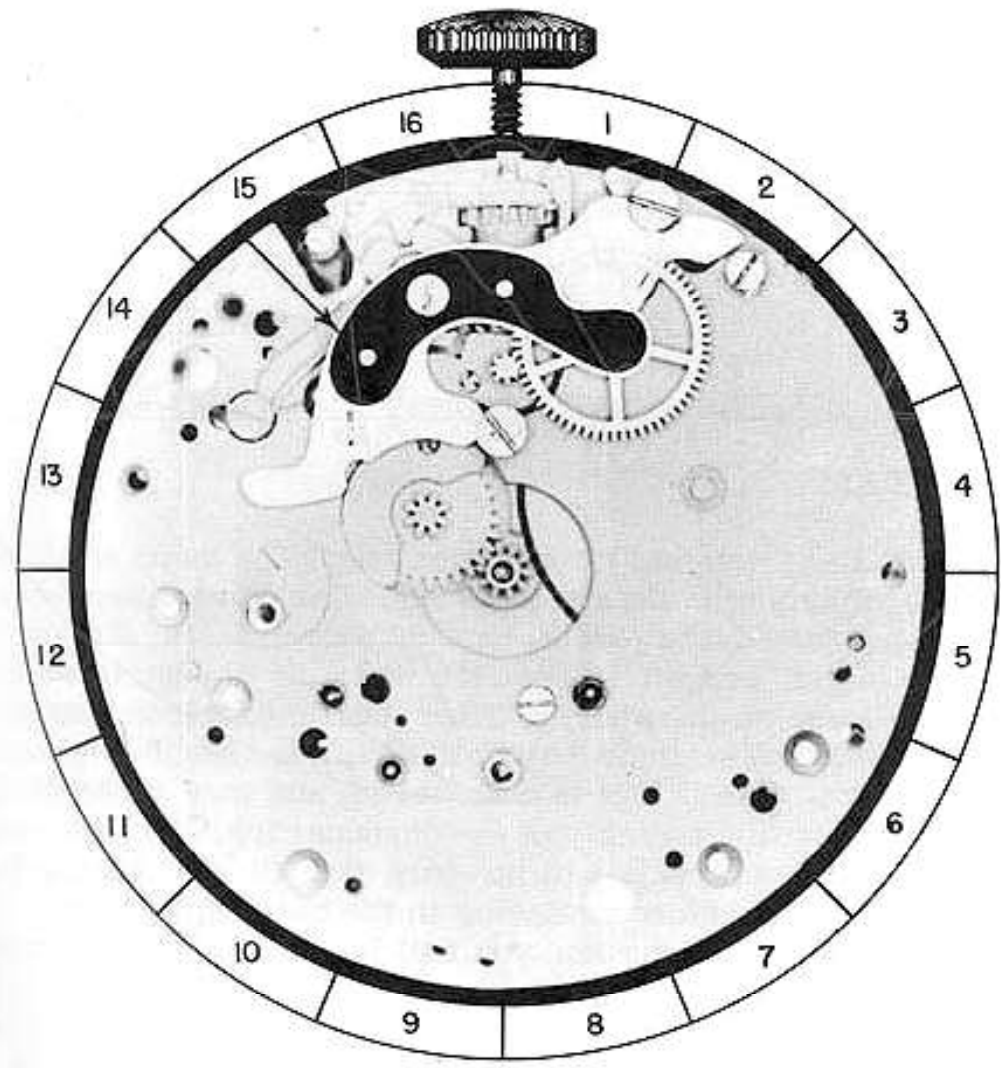

8-A

A. DISASSEMBLY PROCEDURE OF INTERMEDIARY HOUR WHEEL:

To remove this wheel, simply lift it out of place.

B. HAZARDS IN DISASSEMBLY OF INTERMEDIARY HOUR WHEEL:

When lifting this wheel out of place, be careful so as not to tilt the wheel, as this may bend or break the pivot.

C. ASSEMBLY PROCEDURE OF INTERMEDIARY HOUR WHEEL:

Place the wheel in position on the hour pivoted detent with the pivot "A" down in the pivot hole.

REFERENCE: Hour pivoted detent is Assembly 10.

D. FUNCTION OF INTERMEDIARY HOUR WHEEL:

The function of the intermediary hour wheel is to transfer the power from the intermediary driving pinion to the hour register wheel.

REFERENCE: Hour intermediary driving pinion is
Assembly 11.
Hour register wheel is Assembly 3.

REMARKS:

A careful and detailed examination should be made of all wheels before replacing in the chronograph. Each wheel should be examined for burred pivots, bent or burred teeth, dirt or small pieces of grit wedged between the teeth, or any parts which may be loose on the wheel. Often, due to carelessness or lack of detailed observation, the chronograph is completely assembled before some defect is discovered, and may necessitate the complete disassembly of the chronograph. A close examination of these wheels will not only save time by having the wheels correct before replacing in the chronograph, but through close examination, you will learn to quickly recognize a defective wheel.

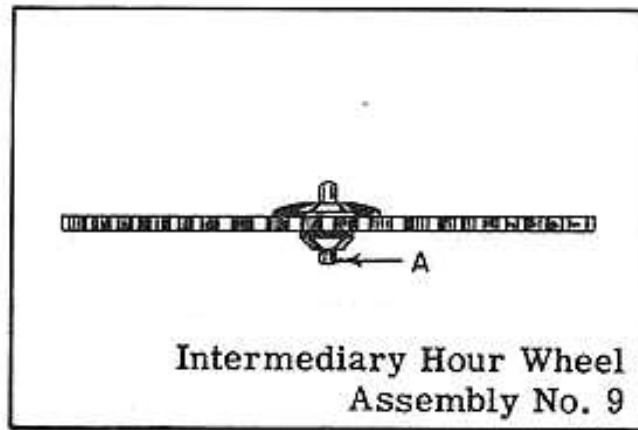

OILING

The bottom pivot of the intermediary hour wheel should be oiled before replacing the pivot in place in the hour pivoted detent. The top pivot should be oiled after bridge for this wheel is placed in watch.

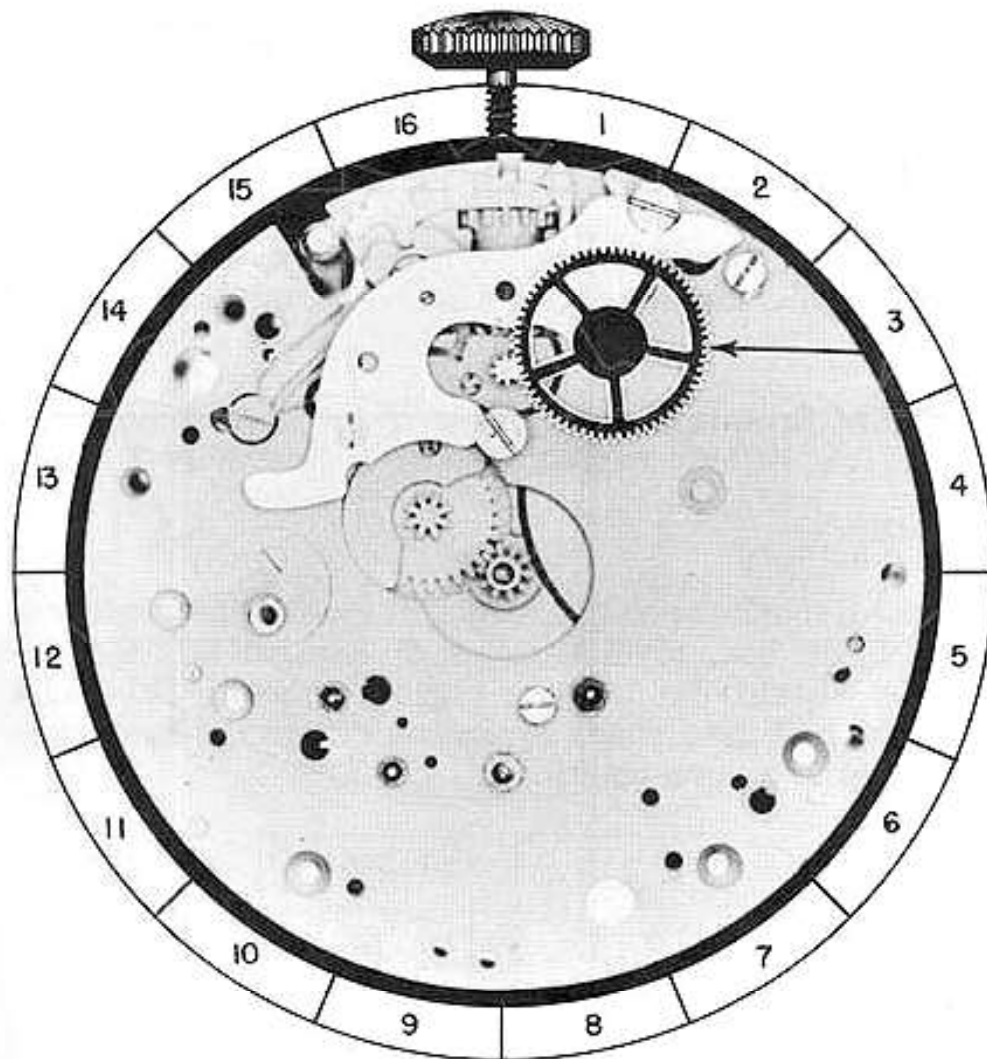

9-A

A. DISASSEMBLY PROCEDURE OF HOUR PIVOTED DETENT:

This detent is held in place by two shouldered screws SS-4 and SS-5 and an eccentric stud. When these screws are removed, the hour pivoted detent will be free on the plate and can be lifted from the stud on the plate.

(The shape of screws for this part is shown at bottom of page)

B. ASSEMBLY PROCEDURE OF HOUR PIVOTED DETENT:

Place the hour pivoted detent in its proper position on plate, with hole "A" in detent over eccentric stud. The detent pivots on this stud. Replace the two shouldered screws SS-4 and SS-5 that hold this detent in place. Make sure that the detent pivots freely under the heads of these screws. You will notice that the photograph shows the position of shouldered screw SS-4 and SS-5. This should aid you in replacing the correct screw in its proper hole.

C. FUNCTION OF HOUR PIVOTED DETENT:

The function of the hour pivoted detent is to engage and disengage the intermediary hour wheel with the hour register wheel.

REFERENCE: Intermediary hour wheel is Assembly 9.
Hour register wheel is Assembly 3.

REMARKS:

When the flyback lever is brought in toward the center of the watch, the hour pivoted detent disengages the intermediary hour wheel from the hour register wheel. This must be done so that the flyback lever can return the hour register wheel to a zero position.

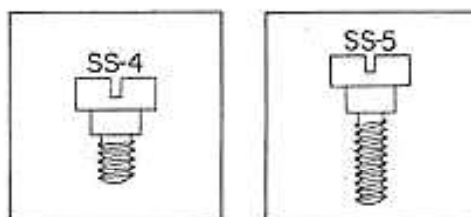

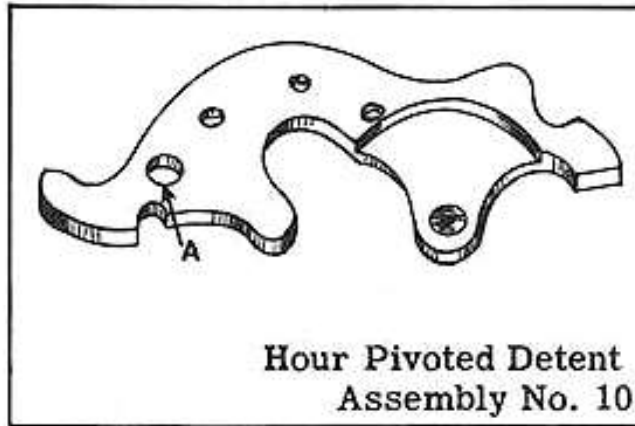

OILING

The eccentric stud that the hour pivoted detent pivots on should be slightly moistened with oil.

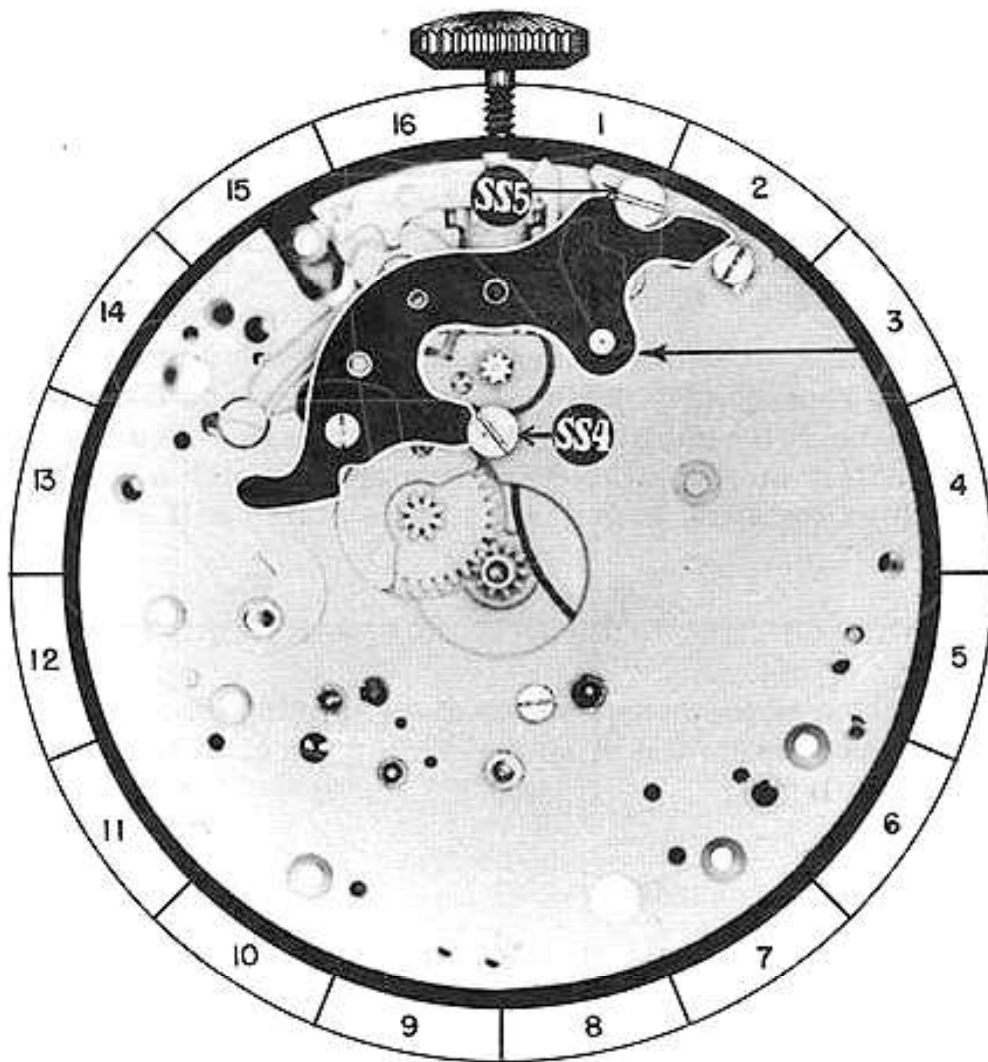

10-A

A. DISASSEMBLY PROCEDURE OF HOUR INTERMEDIARY DRIVING PINION:

To remove this pinion, use two small finely sharpened screwdrivers. Place one screwdriver under one side of pinion, and the other screwdriver on the opposite side. Turn one screwdriver clockwise, while you turn the other one counter-clockwise. This will loosen the pinion from the minute register wheel post, permitting the pinion to be lifted out of place and free from the movement.

NOTICE

The removal of this part completes the disassembly of the dial side of this mechanism. Now turn movement over with the train side facing you, and continue to disassemble the mechanism by the following instructions in this book.

B. ASSEMBLY PROCEDURE OF HOUR INTERMEDIARY DRIVING PINION:

This part should be the last part to be replaced in the hour register mechanism. **DO NOT REPLACE THIS PINION AT THIS TIME.**

Due to the fact that this pinion must be adjusted at the same time it is replaced, it is advisable not to replace this pinion until all the remaining chronograph parts are assembled and the eccentric studs on the train side of the watch adjusted. Further information in regards to this pinion will be found on Page 1.

C. FUNCTION OF THE HOUR INTERMEDIARY DRIVING PINION:

The function of the hour intermediary driving pinion is to transfer the power from the minute register wheel to the hour register mechanism.



Intermediary Driving Pinion
Assembly No. 11

OILING

The intermediate Driving Pinion should not be oiled.

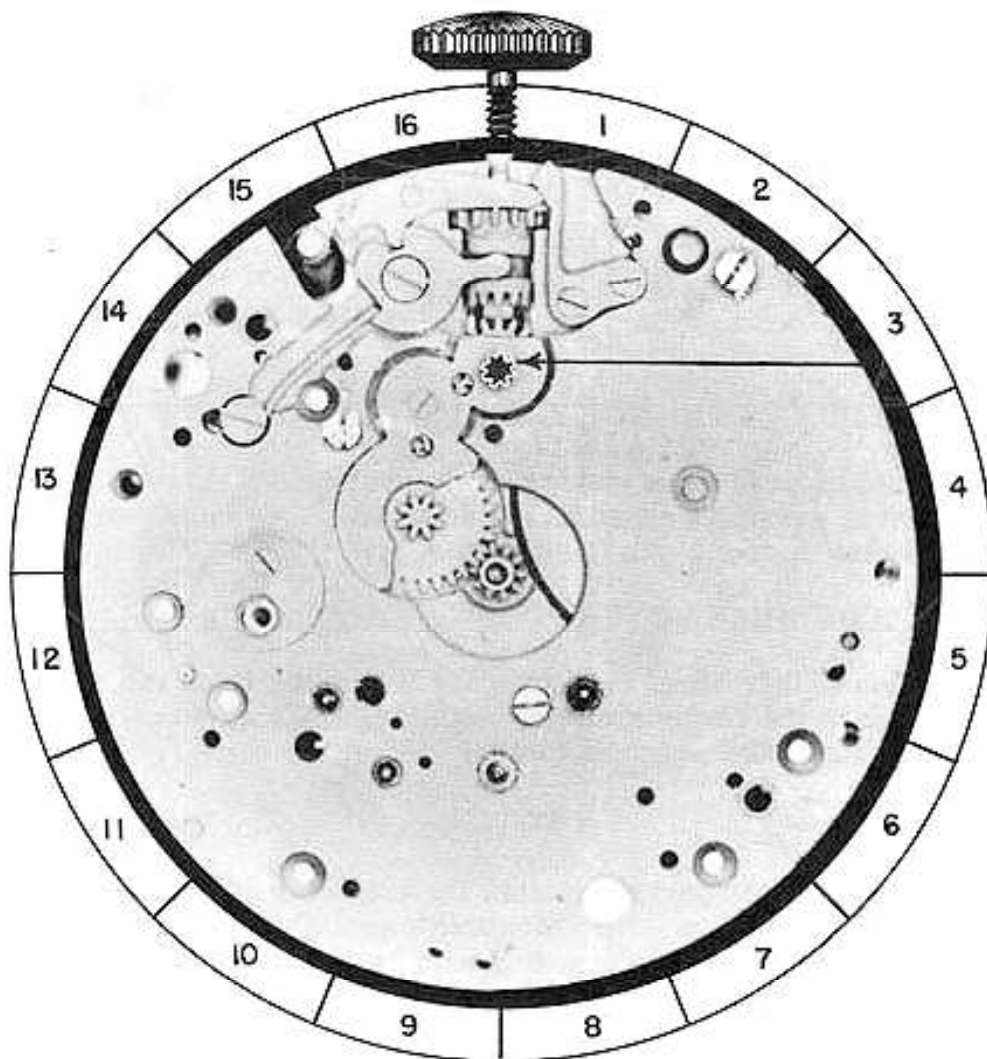

11-A

A. DISASSEMBLY PROCEDURE OF WHEEL OVER FOURTH WHEEL:

The wheel over fourth wheel fits friction tight on the post of fourth wheel pinion. This wheel should be removed with a sweep wheel remover, but can be removed with two small thin edge screwdrivers. The screwdrivers are placed opposite each other under hub of wheel. One screwdriver is turned clockwise while the other screwdriver is turned counter-clockwise. This will free the wheel from the fourth wheel pivot, permitting it to be lifted out of place.

B. HAZARDS IN DISASSEMBLY OF WHEEL OVER FOURTH WHEEL:

The wheel over fourth wheel fits on the very small post of the fourth wheel pinion which is, as you know, very delicate and easily bent or broken. The main reason this wheel is selected to be the first part to be removed is to avoid accidents, such as a slip of the screwdriver etc., causing damage to this wheel. Should the sweep wheel remover be used in removing this wheel, it must be held perfectly upright. This will help prevent bending or breaking of fourth wheel post.

C. ASSEMBLY PROCEDURE OF WHEEL OVER FOURTH WHEEL:

This wheel fits over fourth wheel post. It should be placed on post with hub "A" on wheel down. The wheel over fourth wheel should be pressed down until it is flush with intermediary wheel. A hollow flat face punch should be used to push wheel down.

REFERENCE: Intermediary wheel is shown in isometric drawing on page 14-C.

D. HAZARDS IN ASSEMBLY OF WHEEL OVER FOURTH WHEEL:

Care should be used when staking down this wheel so that the fourth wheel post is not bent or broken. Holding the movement level will lessen chance of damage to fourth wheel post.

E. FUNCTION OF WHEEL OVER FOURTH WHEEL:

The function of this wheel is to transfer the power from the train of the watch to the chronograph mechanism. This wheel continues to turn as long as the watch is running.

NOTICE

The replacing of this part completes the assembly of the train side of chronograph mechanism. Now turn movement over with dial side facing you and continue to assemble mechanism by the following instructions in this book.

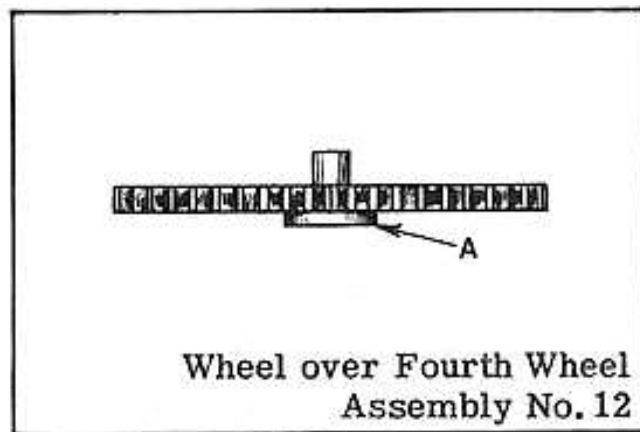

OILING

The wheel over fourth wheel should not be oiled.



12-A

A. DISASSEMBLY PROCEDURE OF CHRONOGRAPH PIVOTED DETENT SPRING:

This spring is held in place by beveled countersink screw BS-1 and a stud. To remove this spring, remove the screw BS-1 and lift the spring straight up free from stud on the plate.

(The shape of screw for this part is shown at bottom of page.)

B. ASSEMBLY PROCEDURE OF CHRONOGRAPH PIVOTED DETENT SPRING:

Place the spring in its proper position on the plate as shown in the photograph, with the hole "B" in spring over the stud on the plate. Now replace the beveled countersink screw BS-1 that holds this spring in place.

C. FUNCTION OF CHRONOGRAPH PIVOTED DETENT SPRING:

The function of the chronograph pivoted detent spring is to hold a tension on the chronograph pivoted detent. This tension forces the intermediary wheel to engage with the seconds wheel.

REFERENCE: Chronograph pivoted detent assembly is Assembly 14.
Intermediary wheel is shown on Page 14C.

REMARKS:

I would like to remind the repairer that it is important that in removing these parts, the screwdriver and tweezers should be sharpened correctly. This will eliminate a lot of unnecessary breakage, marring of plate, loss of part, etc.



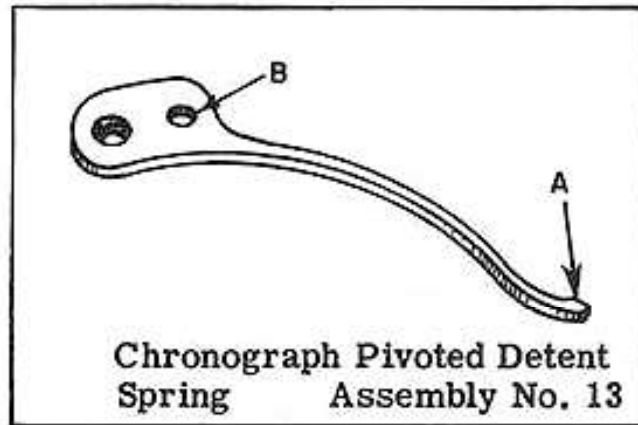

OILING

End "A" of chronograph pivoted detent spring should be slightly moistened with oil at point of contact with chronograph pivoted detent.

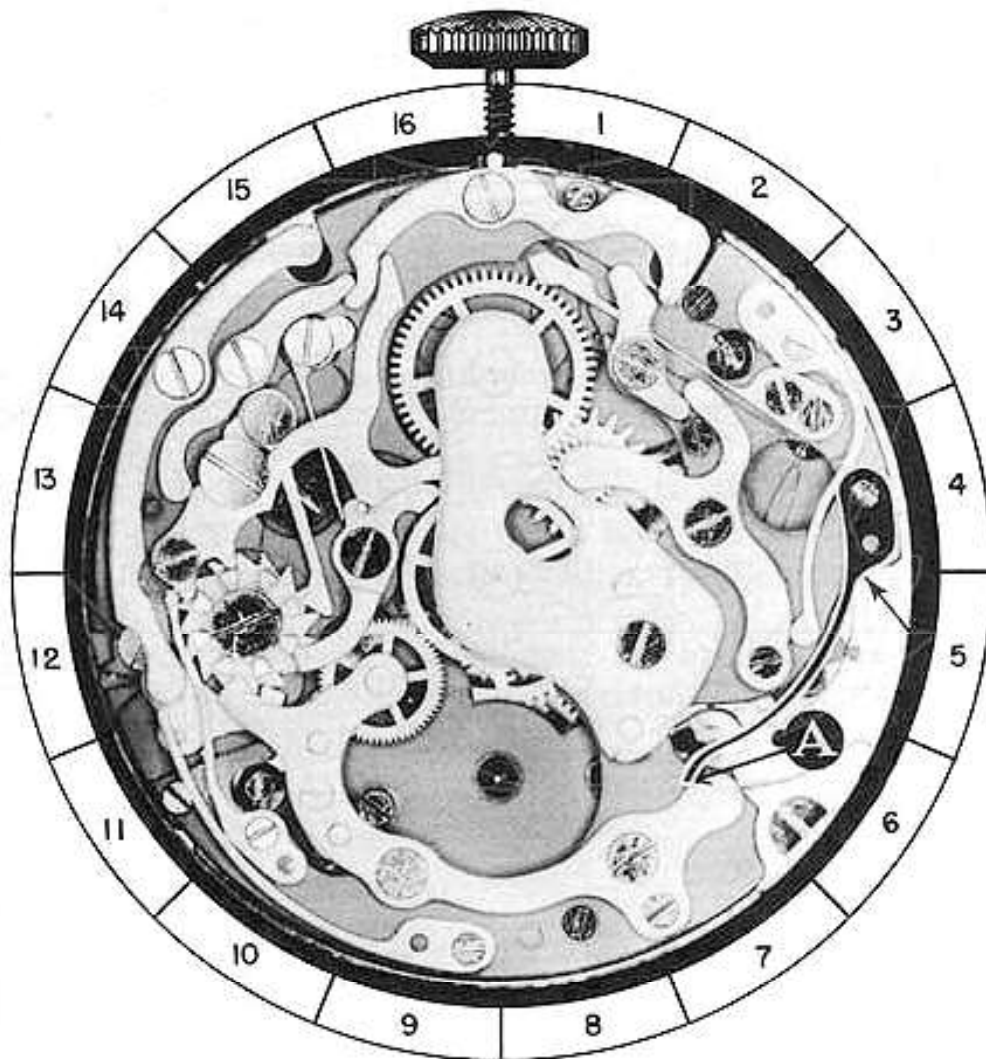

13-A

A. DISASSEMBLY PROCEDURE OF CHRONOGRAPH PIVOTED DETENT ASSEMBLY:

This assembly is held in place by two shouldered screws SS-6 and SS-7 and an eccentric stud. After these screws are removed, this assembly will be free on the plate and can be lifted out of place.

(The shape of screws for this part is shown at bottom of page)

B. ASSEMBLY PROCEDURE OF CHRONOGRAPH PIVOTED DETENT ASSEMBLY:

Place the chronograph pivoted detent assembly in the watch in its proper position, as shown in the photograph. The hole "A" on the chronograph pivoted detent must fit over stud on plate. Now replace the two shouldered screws SS-6 and SS-7 that hold the chronograph pivoted detent assembly in place. These screws that hold this assembly in place are identical. After these screws are replaced, check the detent to see that it pivots freely under the heads of the screws.

C. FUNCTION OF CHRONOGRAPH PIVOTED DETENT ASSEMBLY:

The function of the chronograph pivoted detent assembly is to engage and disengage the intermediary wheel with the seconds wheel.

REFERENCE: Seconds wheel is Assembly 27.
Intermediary wheel is Assembly 14B.

The disassembly of the chronograph pivoted detent bridge and the intermediary wheel is shown and explained on the next page.

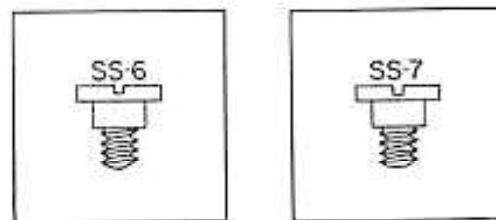

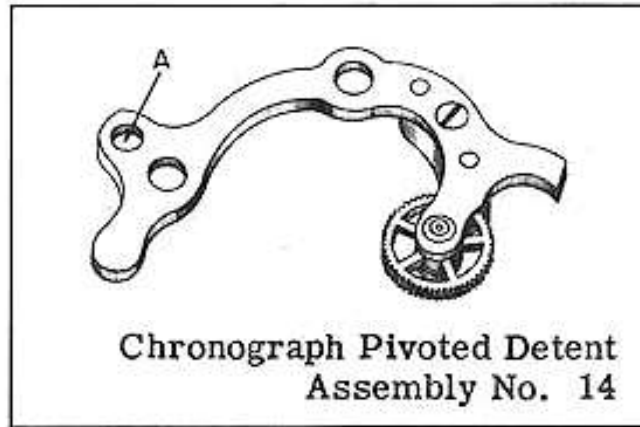

OILING

The eccentric stud that the chronograph pivoted detent pivots on should be slightly moistened with oil.

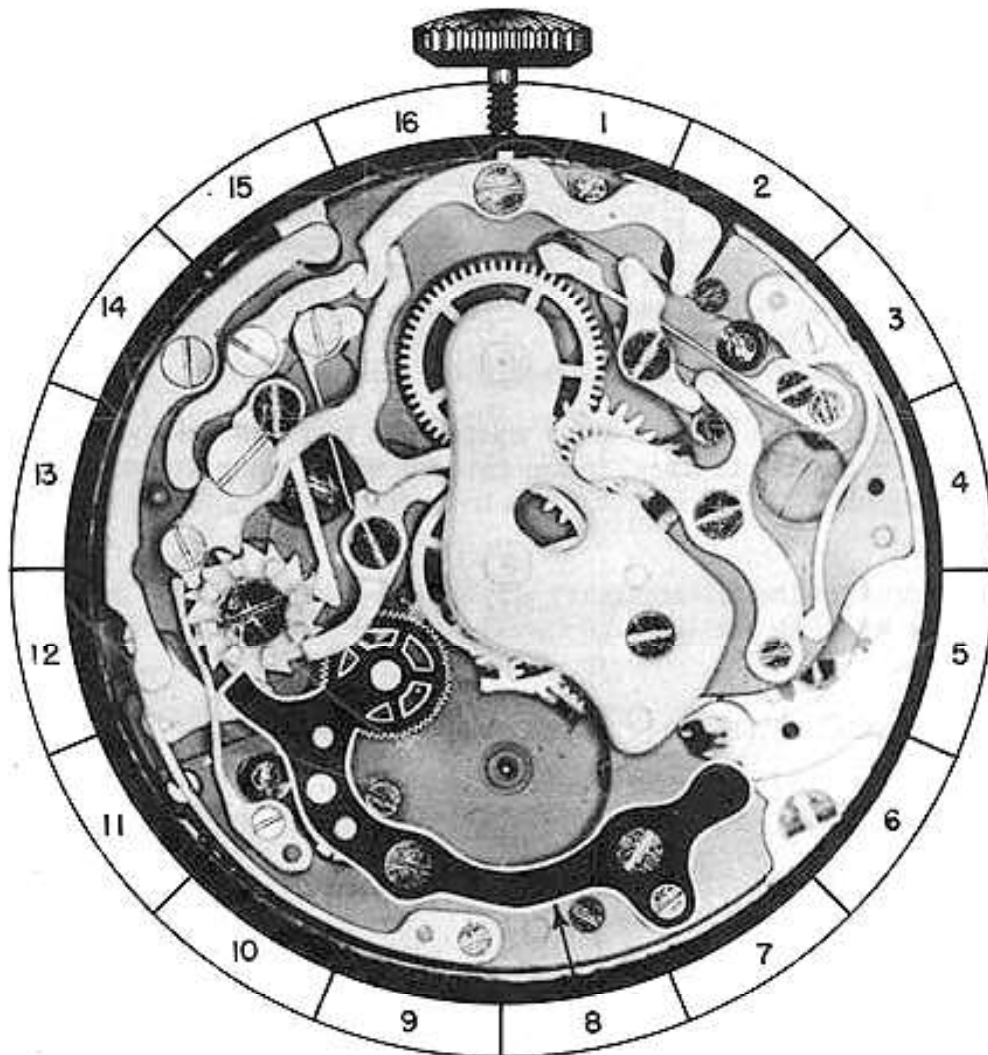

14-A

A. DISASSEMBLY PROCEDURE OF INTERMEDIARY WHEEL AND BRIDGE:

To remove the intermediary wheel bridge, remove beveled countersink screw BS-2 and slide a finely-sharpened screwdriver under intermediary wheel bridge. This will loosen this bridge permitting it to be lifted out of place.

After bridge is removed, you can remove the intermediary wheel by simply lifting it out of place.

(The shape of screw for this part is shown at bottom of page)

B. HAZARDS IN DISASSEMBLY OF INTERMEDIARY WHEEL:

When removing this wheel, hold wheel upright, because if the wheel is tilted when removing it, the pivot on the wheel may be bent or broken.

C. ASSEMBLY PROCEDURE OF INTERMEDIARY WHEEL AND BRIDGE:

Place the pivot "A" on intermediary wheel in its pivot hole in chronograph pivoted detent. Now place the bridge on chronograph pivoted detent with steady pins in proper holes, also making sure that the intermediary wheel pivot is entering pivot hole in bridge. Now press bridge down to proper place and replace beveled countersink screw BS-2. At this place, the intermediary wheel should be checked to see that it pivots freely and it has endshake. Of course, this wheel should not have excessive endshake.

D. FUNCTION OF INTERMEDIARY WHEEL AND BRIDGE:

The function of the intermediary wheel is to transfer the power from the wheel over fourth wheel to the seconds wheel when these wheels are engaged. This wheel continues to turn as long as the watch is running.

The function of the intermediary wheel bridge is to hold the intermediary wheel in position and upright so that this wheel can function properly.

REFERENCE: Wheel over fourth wheel is Assembly 12.

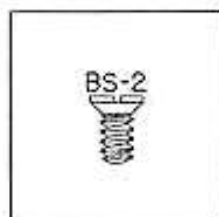

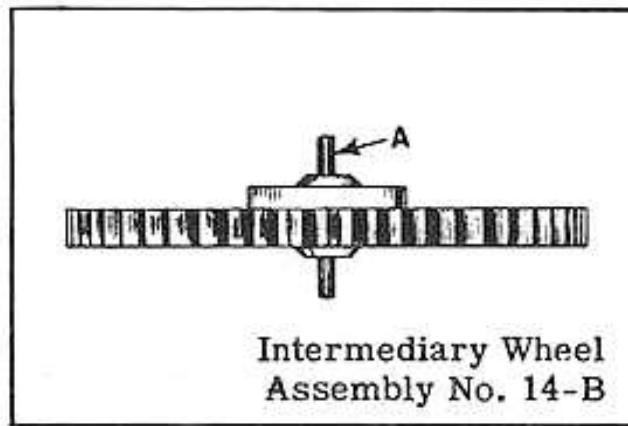

OILING

The top and bottom pivots on the intermediary wheel should be oiled after bridge for this wheel is replaced. Oil these pivots as you usually oil the train pivots in a watch.

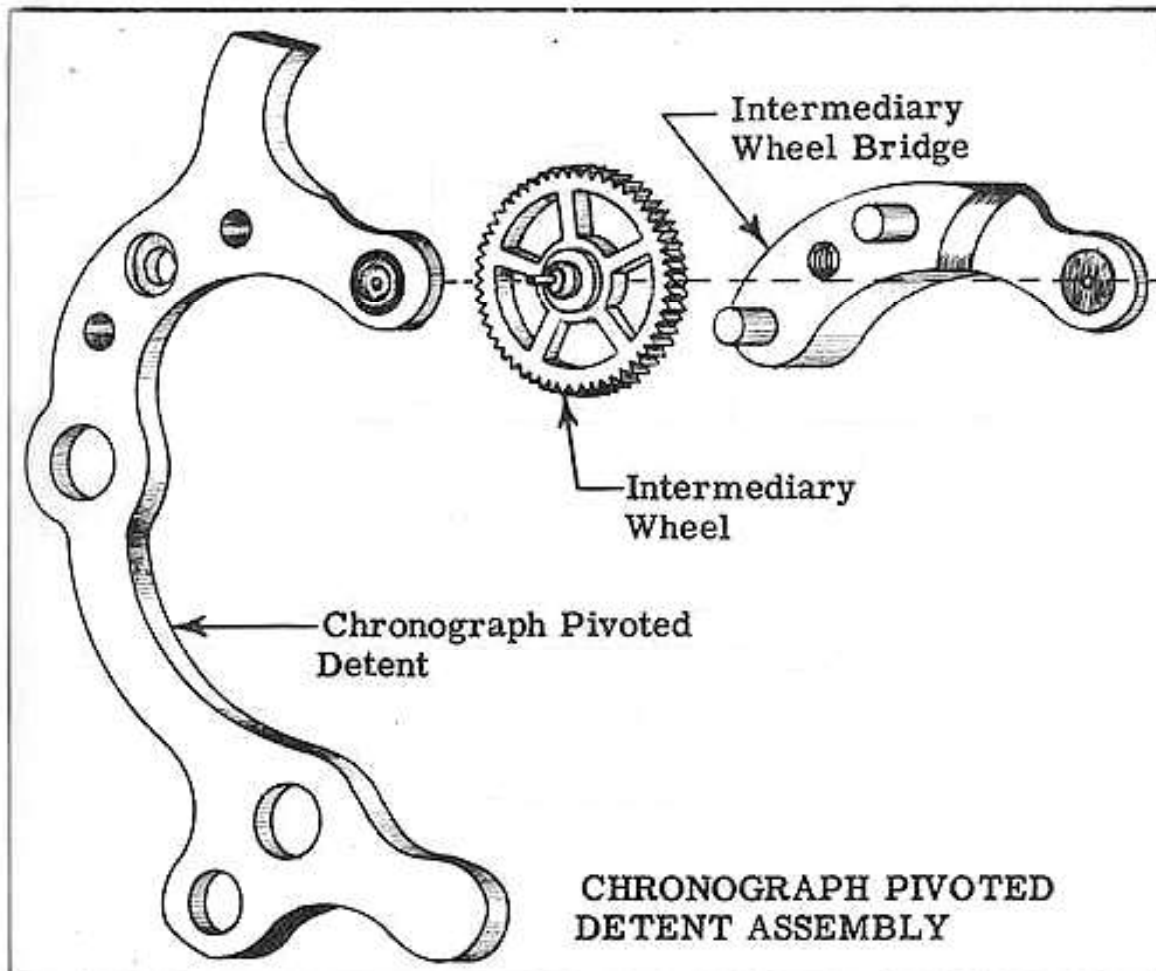

A. DISASSEMBLY PROCEDURE OF ACTUATING DETENT LEVER SPRING:

This spring is held in place by beveled countersink screw BS-3. When this screw is removed, this spring can be lifted from stud on plate and removed.

(The shape of screw for this part is shown at bottom of page)

B. ASSEMBLY PROCEDURE OF ACTUATING DETENT LEVER SPRING:

Place spring in its proper position on plate with hole "B" in spring over stud in plate. Now replace beveled countersink screw BS-3 that holds this spring in place.

C. FUNCTION OF ACTUATING DETENT LEVER SPRING:

The function of the actuating detent lever spring is to hold the joint hook in contact with the castle wheel, also to hold end "A" of actuating detent lever in toward the center of the watch.

REFERENCE: Castle wheel is Assembly 24.
Joint hook is Assembly 18.
Actuating detent lever is Assembly 17.

REMARKS:

You will notice in this mechanism that you have very little trouble in removing springs. You will notice that most springs on this chronograph fit over a stud on the plate and are held in place by a screw. When removing a screw from these springs, the spring pivots on the stud and automatically releases the tension on itself, permitting the spring to be easily lifted out of place without any danger of the spring snapping away. This makes this type of spring easier to remove and replace.



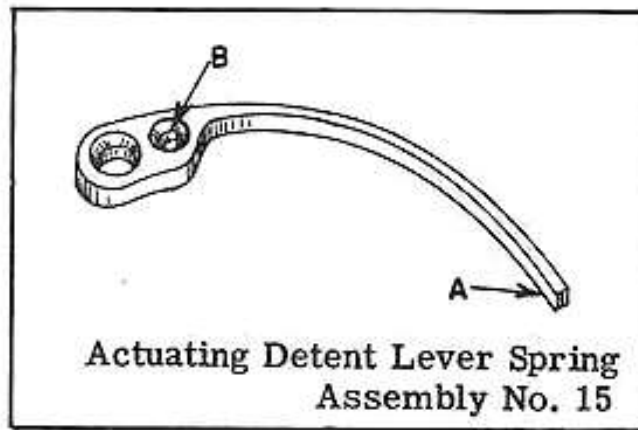

OILING

End "A" of actuating detent lever spring should be slightly moistened with oil at point of contact with actuating detent lever.

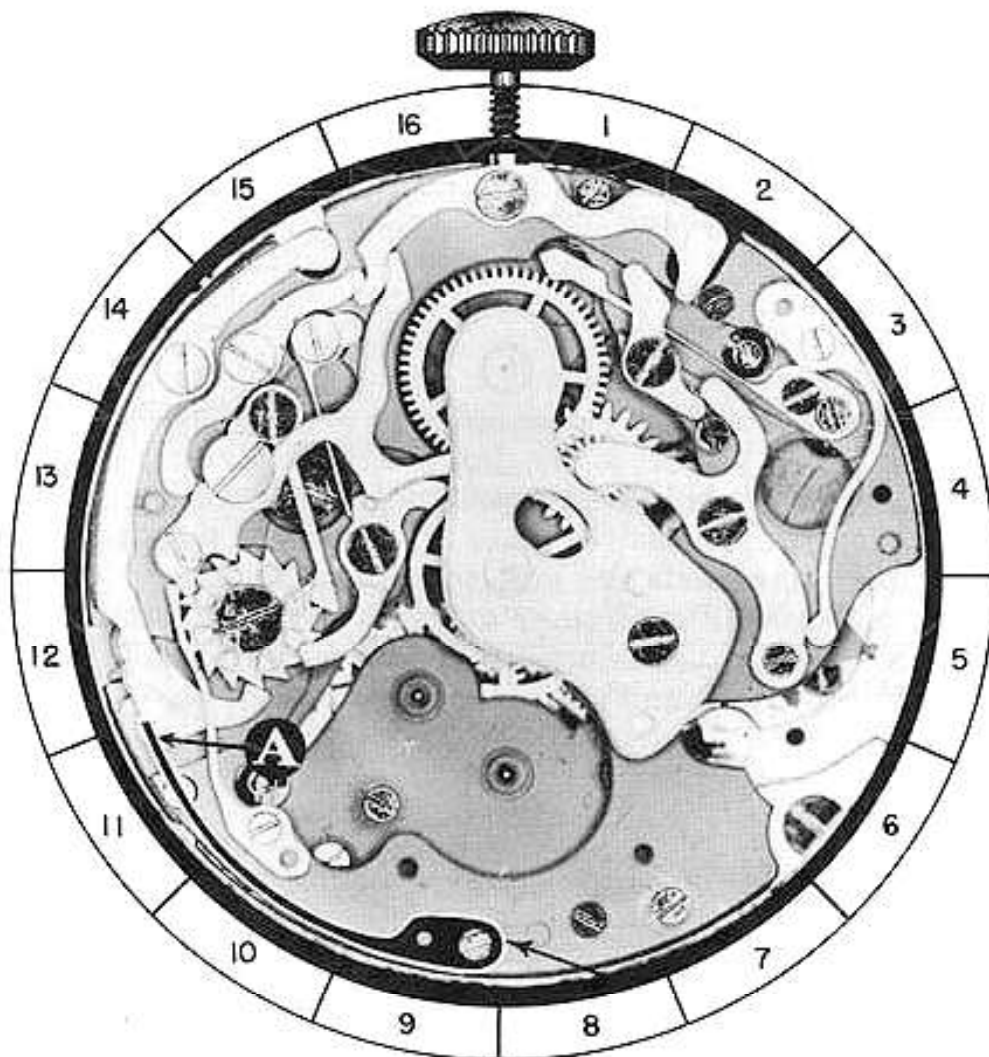

15-A

A. DISASSEMBLY PROCEDURE OF FLYBACK LEVER SPRING:

This spring is held in place by a beveled countersink screw BS-4 and a stud on plate. Remove screw and lift spring straight up free from stud on plate.

(The shape of screw for this part is shown at bottom of page)

B. ASSEMBLY PROCEDURE OF FLYBACK LEVER SPRING:

Place the flyback lever spring in its proper position on plate, as shown in the photograph, with the hole "B" in spring over stud in plate. Now replace beveled countersink screw BS-4 that holds this spring in place.

C. FUNCTION OF FLYBACK LEVER SPRING:

The function of the flyback lever spring is to hold a tension on flyback lever holding flyback lever away from the center of the watch.

REFERENCE: Flyback lever is Assembly 19.

REMARKS:

After replacing the spring in the chronograph mechanism, it is advisable to check these springs to see that they are not scraping on the plate. Many times after replacing a spring, the spring cannot hold its proper tension on the part, because it is scraping on the plate. To correct this, place the spring on a lead anvil and give top of spring a few light taps with a watchmaker's hammer at location "C" on this spring, which is shown in the isometric drawing. Now place the spring in the watch and check to see that it is free.



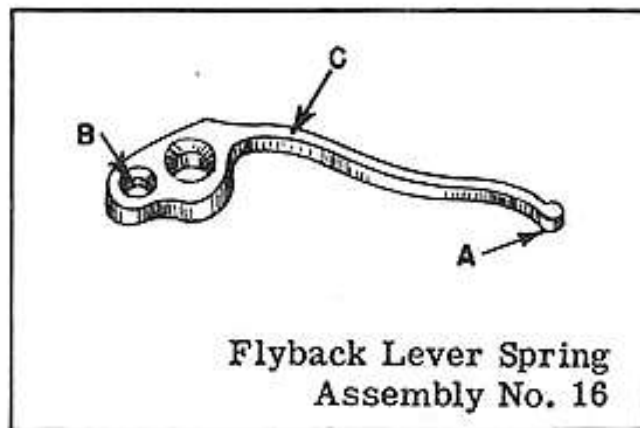

Flyback Lever Spring
Assembly No. 16

OILING

End "A" of flyback lever spring should be slightly moistened with oil at point of contact with flyback lever.

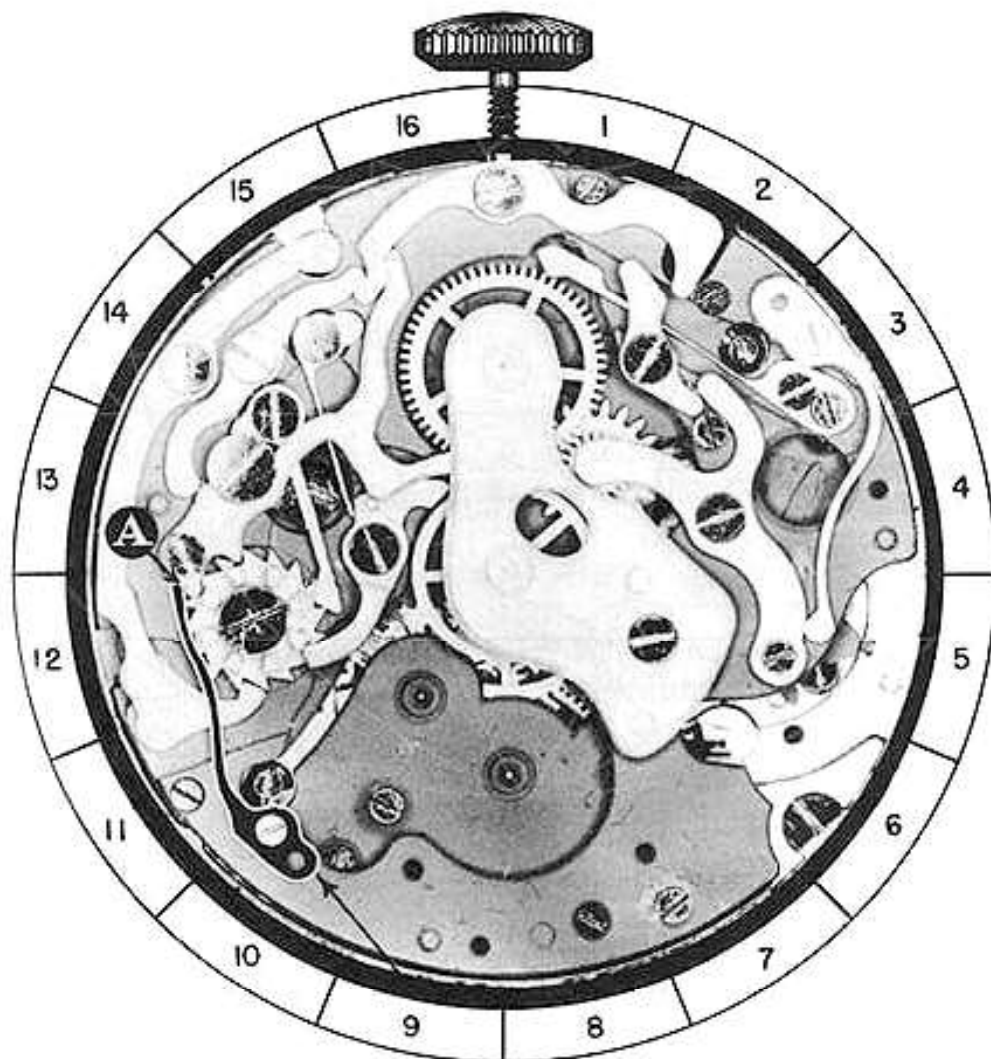

16-A

A. DISASSEMBLY PROCEDURE OF ACTUATING DETENT LEVER:

This detent lever is held in place by a shouldered screw SS-8. When this shouldered screw is removed, the actuating detent lever will be free on the plate, and can be lifted out of place.

(The shape of screw for this part is shown at bottom of page)

B. ASSEMBLY PROCEDURE OF ACTUATING DETENT LEVER:

Place the actuating detent lever in its proper position on the plate, as shown in the photograph, with pin "A" on actuating detent lever in hole in joint hook. Now replace the shouldered screw SS-8 that holds actuating detent lever in place. After screw is replaced, check actuating detent to see that it moves freely under head of shouldered screw. Also check joint hook to see that it is free and not binding.

C. FUNCTION OF ACTUATING DETENT LEVER:

The function of the actuating detent lever, when pushed, is to bring the joint hook away from the center of the watch. This rotates the castle wheel, making the castle wheel move one tooth.

REFERENCE: Joint hook is Assembly 18.
Castle wheel is Assembly 24.

REMARKS:

The stop pin, shown as "C" in the photograph, limits the movement of the actuating detent lever towards the center of the watch.

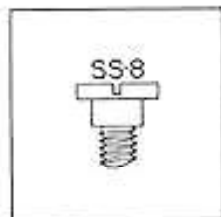

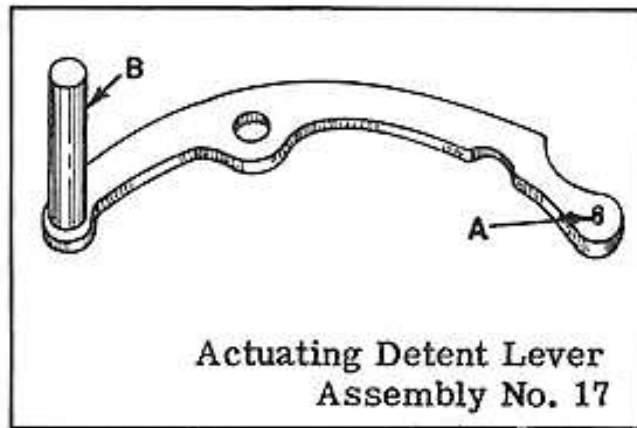

OILING

These two points on actuating detent lever should be slightly moistened with oil:

1. The shoulder of screw actuating detent pivots on.
2. Pin "A" that holds joint hook.

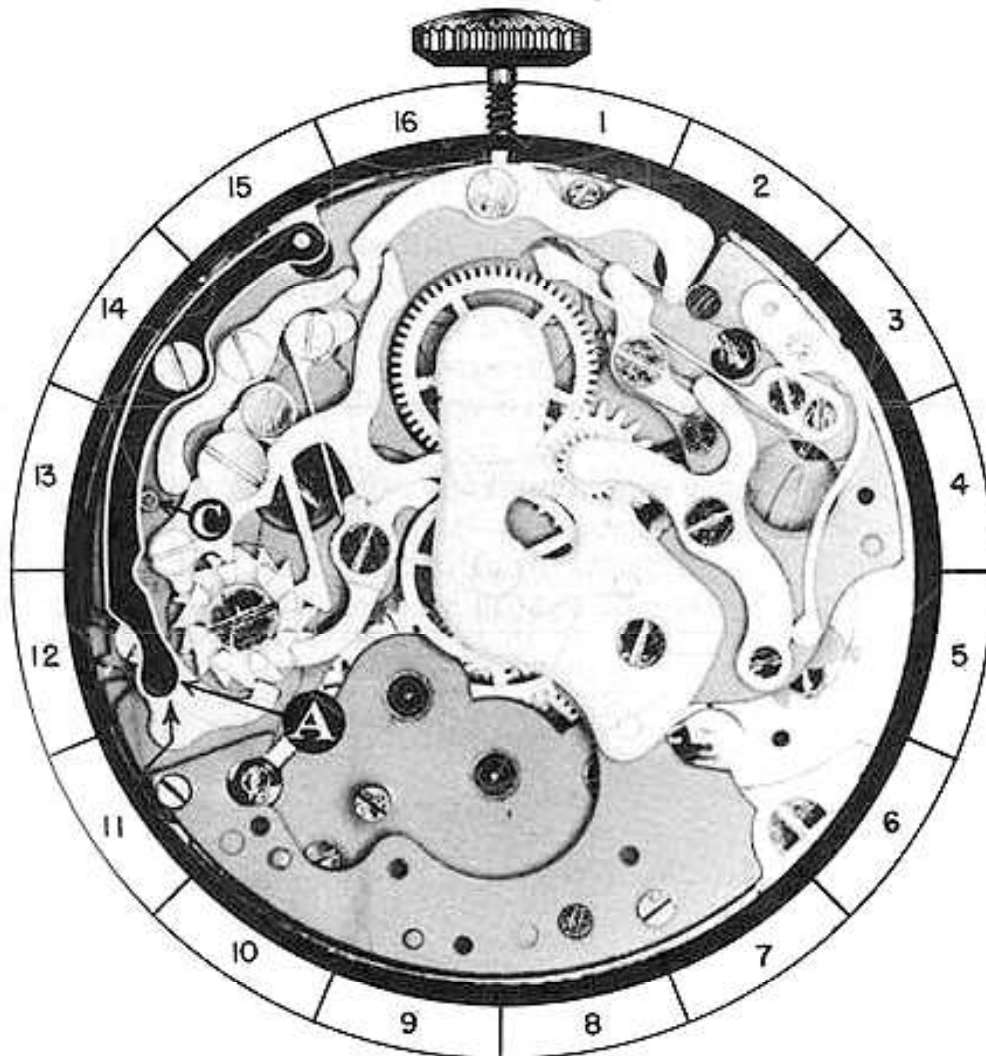

17-A

A. DISASSEMBLY PROCEDURE OF JOINT HOOK:

To remove joint hook, simply lift it out of place.

B. ASSEMBLY PROCEDURE OF JOINT HOOK:

Place joint hook in its proper position as shown on photograph with end "A" of joint hook engaged with ratchet teeth on castle wheel. The next part to be replaced will hold the joint hook in place.

C. FUNCTION OF JOINT HOOK:

The function of the joint hook, when moved away from the center of the watch, is to turn the castle wheel one tooth.

REFERENCE: Castle wheel is Assembly 24.

REMARKS:

The face "A" on the joint hook slides across the ratchet teeth on the castle wheel. Therefore, you should check the face "A" to see that there are no pits of rust or roughness at this location. Any pits of rust should be removed by polishing with diamantine on a hard wood block.

When assembling the chronograph, check the working points on each part. By this examination, not only will you do a better job of repairing a complicated watch, but you will develop a habit that will enable you to instantly recognize a defective part.

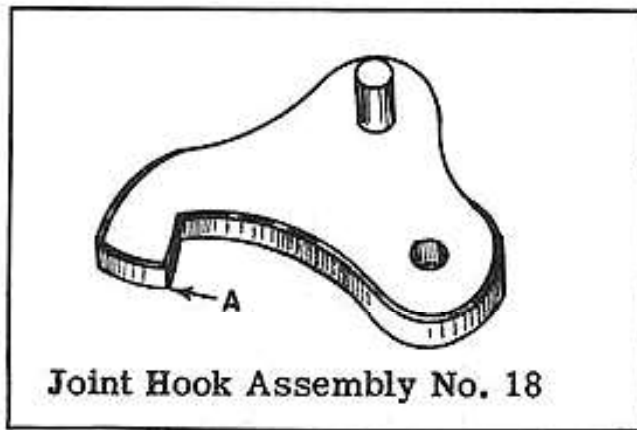

OILING

The joint hook should not be oiled

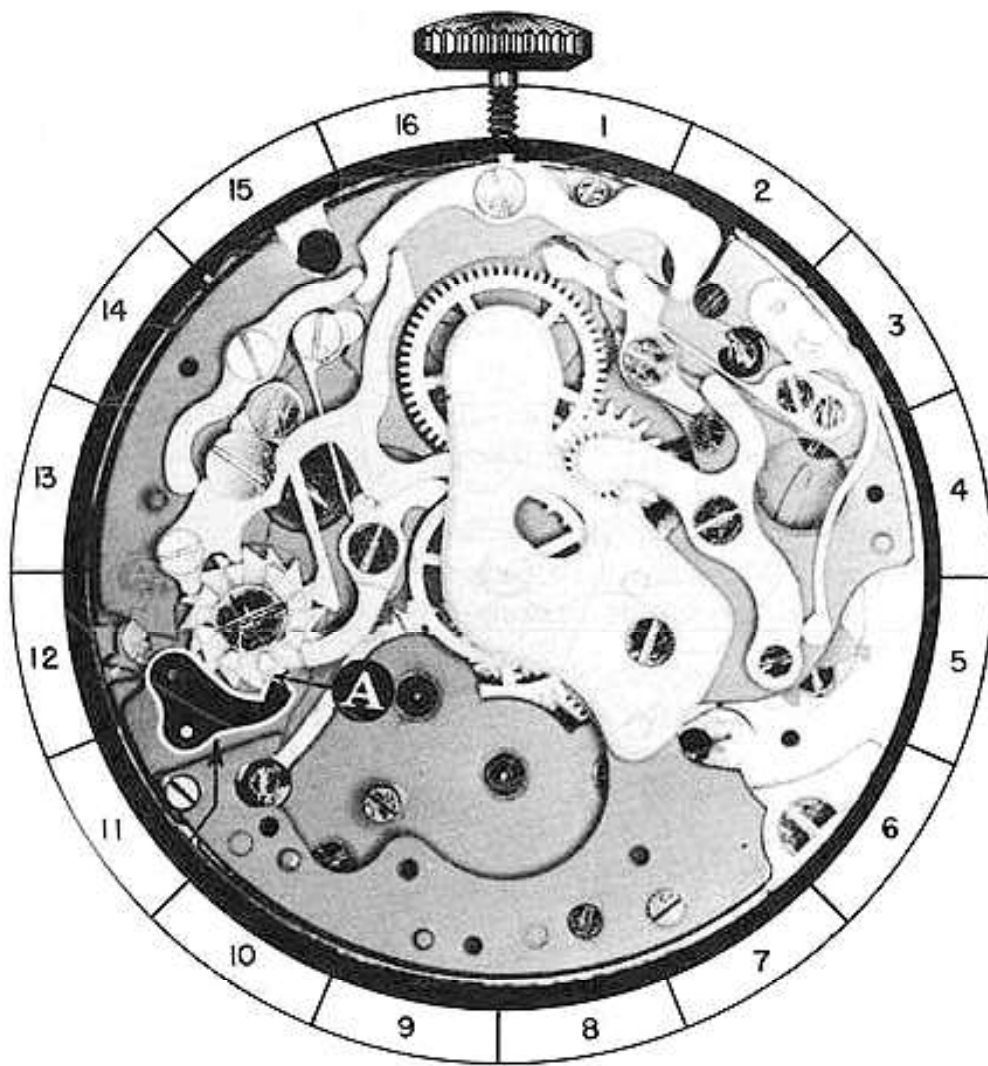

18-A

A. DISASSEMBLY PROCEDURE OF FLYBACK LEVER:

The flyback lever is held in place by two shouldered screws SS-9 and SS-10. After these screws are removed, the flyback lever can be slid from beneath the seconds wheel and minute register wheel bridge and lifted out of place.

REFERENCE: Seconds wheel and minute register wheel bridge is Assembly 25.

(The shape of screws for this part is shown at bottom of page)

B. ASSEMBLY PROCEDURE OF FLYBACK LEVER:

Place flyback lever in its proper position on plate with arm "B" of flyback lever under seconds wheel and minute register wheel bridge. Now replace shouldered screws SS-9 and SS-10. The photograph will show you the position of these screws. After these screws are replaced, check flyback lever to see that it pivots freely under the heads of these screws.

C. FUNCTION OF FLYBACK LEVER:

The functions of the flyback lever when forced toward the center of the watch are:

1. The surface "D" on flyback lever contacts pin "B" on brake lever disengaging the brake lever from the seconds wheel.
2. The ends "A" and "B" contact the hearts on the seconds wheel and the minute register wheel, returning these two wheels and the hands attached to them to a zero position.

REFERENCE: Seconds wheel is Assembly 27.
Minute register wheel is Assembly 26.
Brake lever is Assembly 22.

(Continued on Page 39)

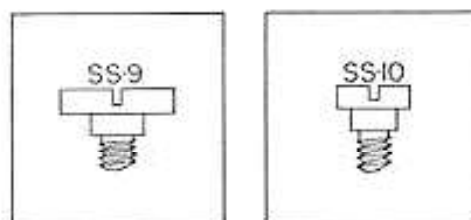

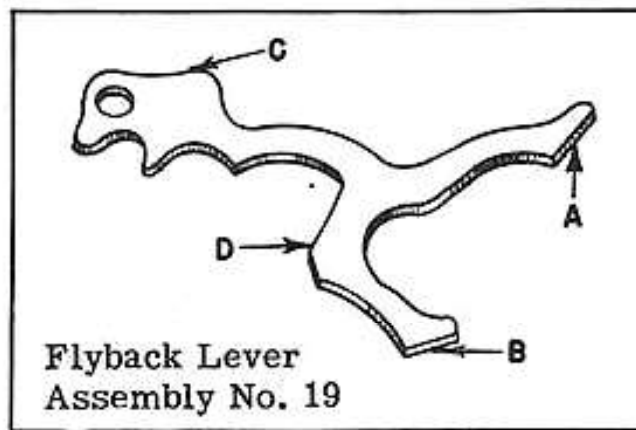

OILING

These points on flyback lever should be slightly moistened with oil:

1. Shoulder of screw that lever pivots on.
2. Point "C" on lever that contacts flyback connecting lever.
3. Point "D" on lever that contacts pin "B" on brake lever.

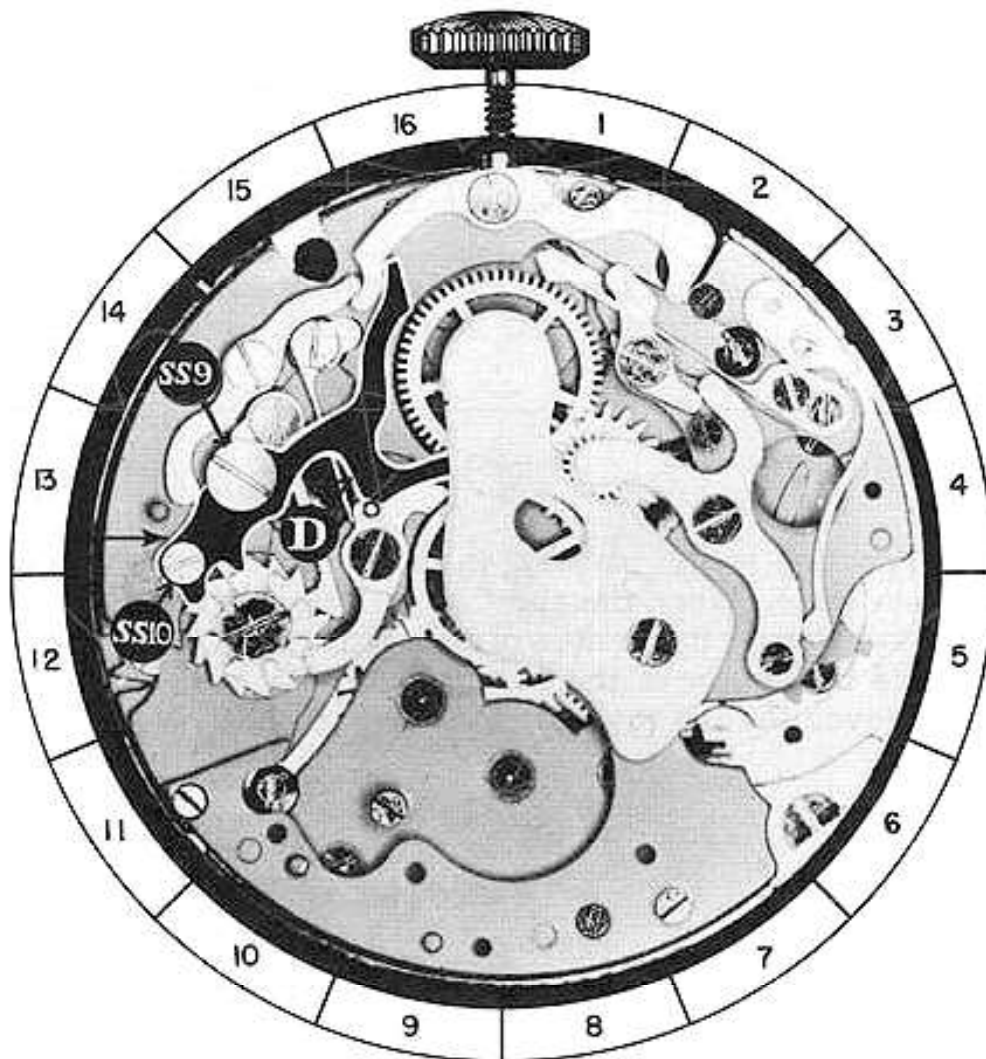

19-A

A. DISASSEMBLY PROCEDURE OF FLYBACK CONNECTING LEVER:

This lever is held in place by a shouldered screw SS-11. When this screw is removed, flyback connecting lever will be free on the plate and can be lifted out of place.

(The shape of screw for this part is shown at bottom of page)

B. ASSEMBLY PROCEDURE OF FLYBACK CONNECTING LEVER:

Place the flyback connecting lever in its proper position on the plate, as shown on photograph. Now replace shouldered screw SS-11 that holds this part in place. After screw is replaced, check to see that flyback connecting lever pivots freely under the head of this screw.

C. FUNCTION OF FLYBACK CONNECTING LEVER:

The flyback connecting lever connects the push piece for setting back to zero to the flyback lever.

REFERENCE: Flyback lever is Assembly 19.
Push piece for setting back to zero is Assembly 33.

REMARKS:

The connecting lever, pivoting in the center, works somewhat like a see-saw. When the end "A" of connecting lever is forced away from the center of the watch, end "B" is forced in toward the center of the watch. End "B" then forces the flyback lever toward the center of the watch.

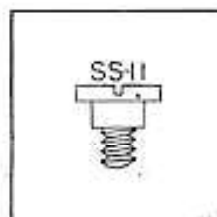

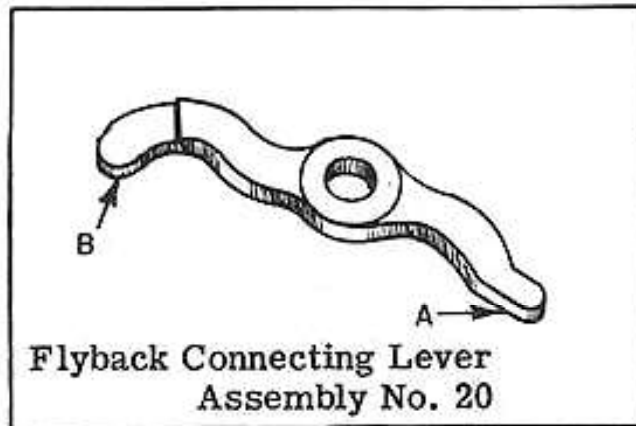

OILING

These points on the flyback connecting lever should be slightly moistened with oil:

1. Shoulder of screw on which flyback connecting lever pivots.
2. End "A" that contacts push piece for setting back to zero.

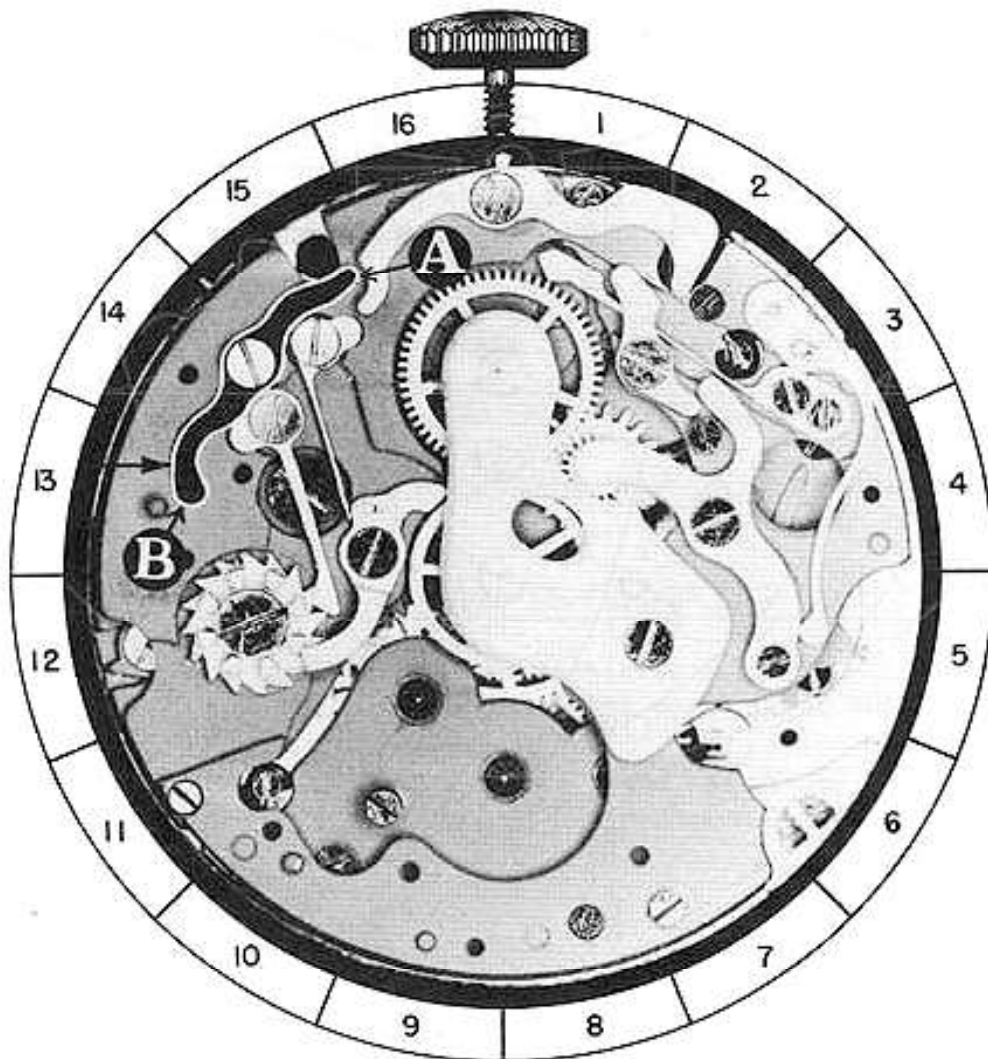

20-A

A. DISASSEMBLY PROCEDURE OF BRAKE LEVER SPRING:

This spring is held in place by a fillister head screw FS-7. After this screw is removed, slide a finely-sharpened screwdriver under the base of the spring indicated as "B" in the isometric drawing. This will loosen the spring from the plate permitting it to be lifted out of place.

(The shape of screw for this part is shown at bottom of page)

B. HAZARDS IN DISASSEMBLY OF BRAKE LEVER SPRING:

The brake lever spring is a fine and delicate spring. Care should be taken in removing this spring so that it is not bent or harmed in any way, also in loosening spring by sliding screwdriver under it. Care should be taken not to mar the plate.

C. ASSEMBLY PROCEDURE OF BRAKE LEVER SPRING:

Place the brake lever spring in its proper position on plate as shown in photograph, with end "A" of spring in contact with point "C" on brake lever. Now press spring down to proper position and replace fillister head screw FS-7 that holds this part in place.

REFERENCE: Brake lever is Assembly 22.

D. HAZARDS IN ASSEMBLY OF BRAKE LEVER SPRING:

The brake lever spring should be handled with care while it is being replaced.

E. FUNCTION OF BRAKE LEVER SPRING:

The function of the brake lever spring, when permitted, is to force the brake lever to contact the seconds wheel.

REFERENCE: Brake lever is Assembly 22.
Seconds wheel is Assembly 27.

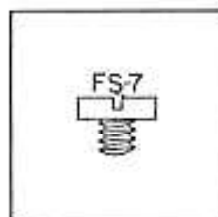

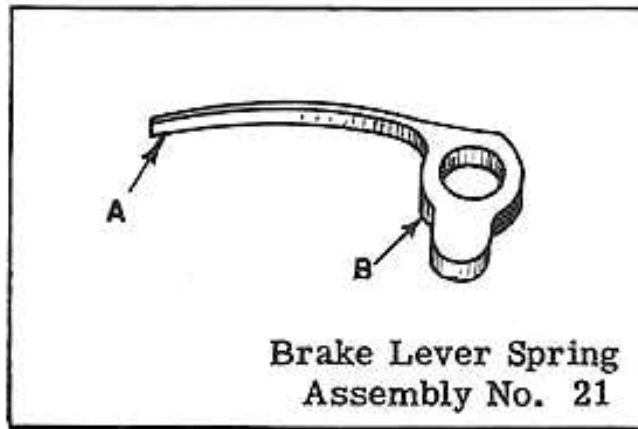

OILING

End "A" of brake lever spring that contacts brake lever should be slightly moistened with oil.

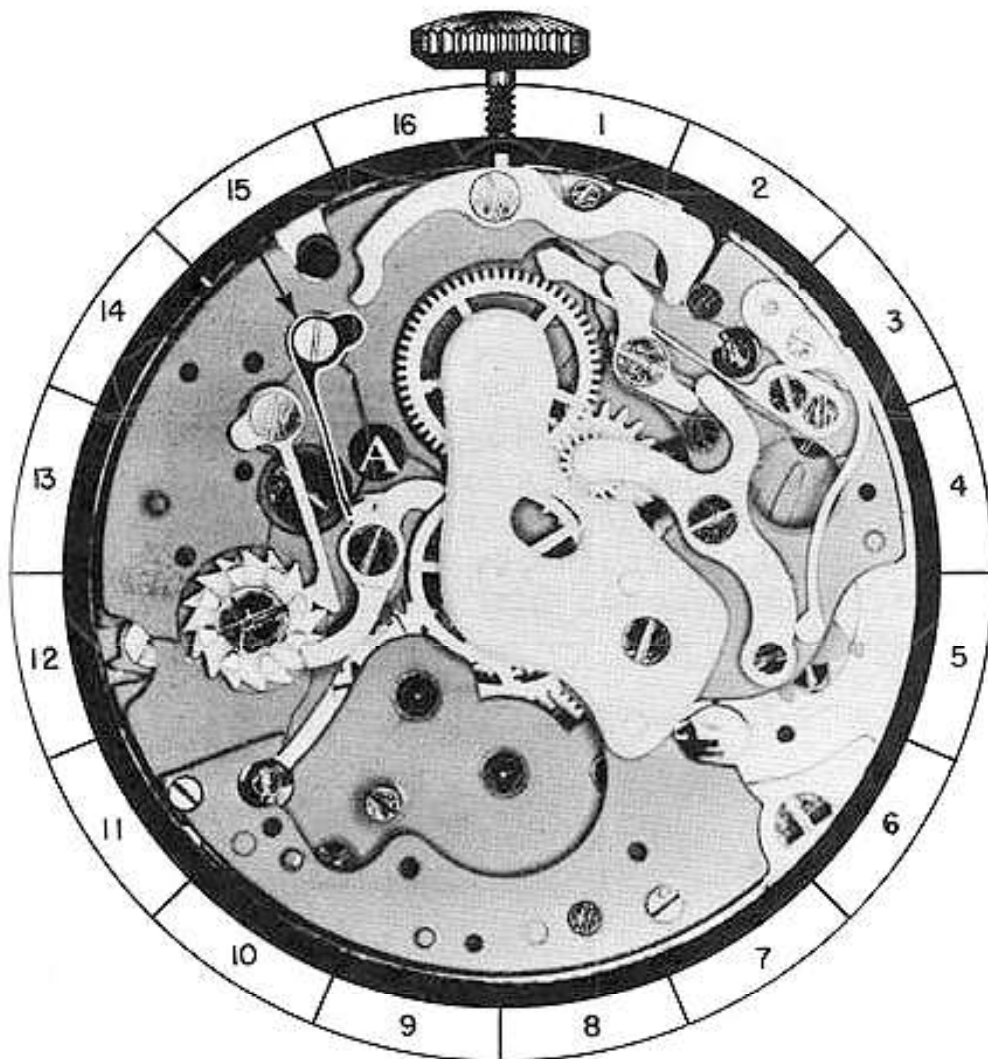

21-A

A. DISASSEMBLY PROCEDURE OF BRAKE LEVER:

The brake lever is held in place by fillister head screw FS-8. When this screw is removed, brake lever can be lifted out of place.

(The shape of screw for this part is shown at bottom of page)

B. ASSEMBLY PROCEDURE OF BRAKE LEVER:

Place the brake lever in its proper position on the plate, as shown on photograph. Now, replace fillister head screw FS-8 that holds brake lever in place. Check to see that brake lever pivots freely under the head of this screw.

C. FUNCTION OF BRAKE LEVER:

The function of the brake lever is to hold the seconds wheel in a stationary position when the chronograph mechanism is disengaged from the seconds wheel.

REFERENCE: Seconds wheel is Assembly 27.

REMARKS:

When the flyback lever is brought in towards the center of the watch, the flyback lever contacts pin "B" on brake lever, disengaging the brake lever from the seconds wheel. Naturally, the brake lever must be disengaged at this time so that the flyback lever can bring seconds wheel back to a zero position.

REFERENCE: Flyback lever is Assembly 19.

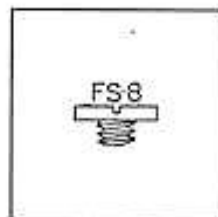

Brake Lever
Assembly No. 22

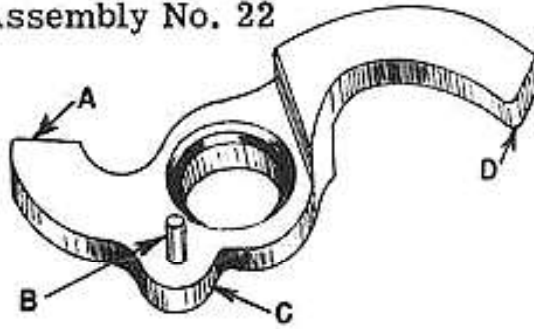

OILING

The shoulder of screw that brake lever pivots on should be slightly moistened with oil.

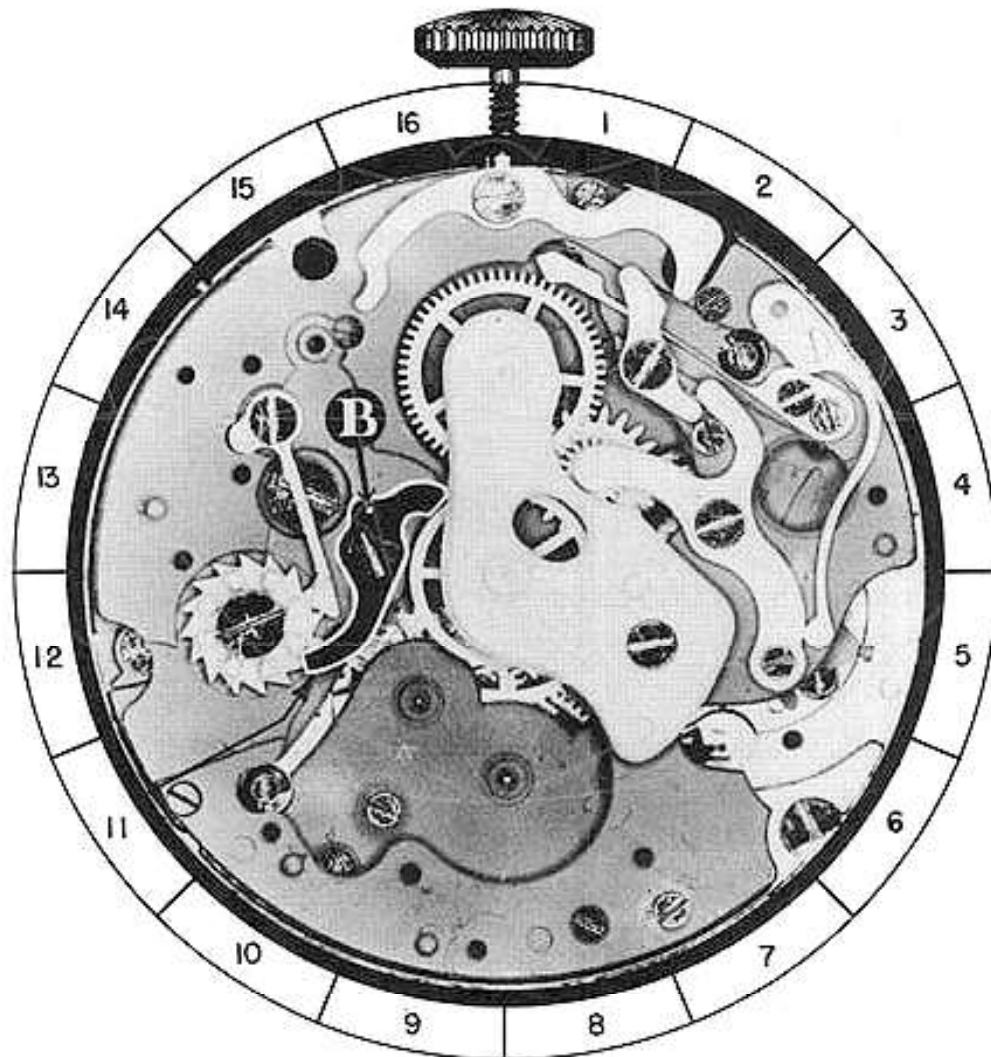

22-A

A. DISASSEMBLY PROCEDURE OF CASTLE WHEEL PAWL:

The castle wheel pawl is held in place by fillister head screw FS-9 and fits over a hollow stud in a recess in the plate. When the fillister head screw FS-9 is removed, slide a finely sharpened screwdriver under the base of the pawl to loosen it from the plate and lift it from the movement.

(The shape of screw for this part is shown at bottom of page)

B. ASSEMBLY PROCEDURE OF CASTLE WHEEL PAWL:

Before replacing pawl, look at the end "A" of pawl which should be polished. If this end of pawl is not polished, it cannot perform its function properly. This pawl slides across the ratchet teeth on castle wheel, keeping castle wheel in its proper position, for instance, if the castle wheel would only move one-half a tooth, the pawl should bring the castle wheel back to its original position. You can easily see that if end "A" of pawl is rough or rusty, it may not pull the castle wheel back to its correct position.

To replace the castle wheel pawl, place it in position, as shown in the photograph, with the hole in the pawl over the hollow stud in plate. Make sure that end "A" of pawl is meshing into the ratchet teeth on castle wheel. Now press the pawl down to proper place with back of tweezers, and replace fillister screw FS-9 that holds the pawl in place.

REFERENCE: Castle wheel is Assembly 24.

C. FUNCTION OF CASTLE WHEEL PAWL:

The function of this pawl is to hold the castle wheel in position until it is moved manually, also the tension of pawl on ratchet teeth makes sure the castle wheel turns exactly one tooth each time it is turned.

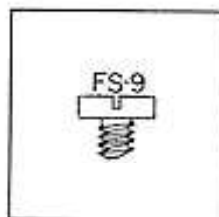

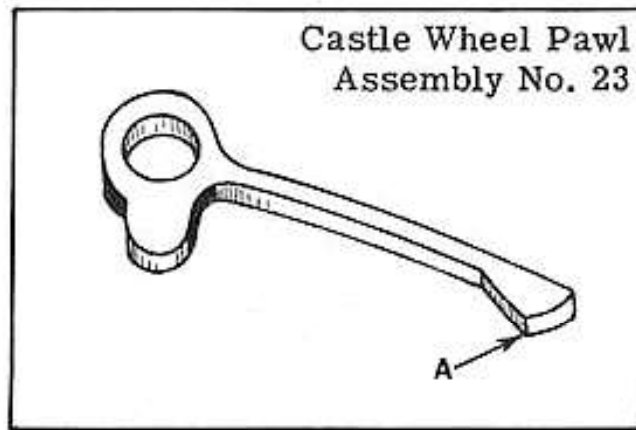

OILING

The castle wheel pawl should not be oiled.

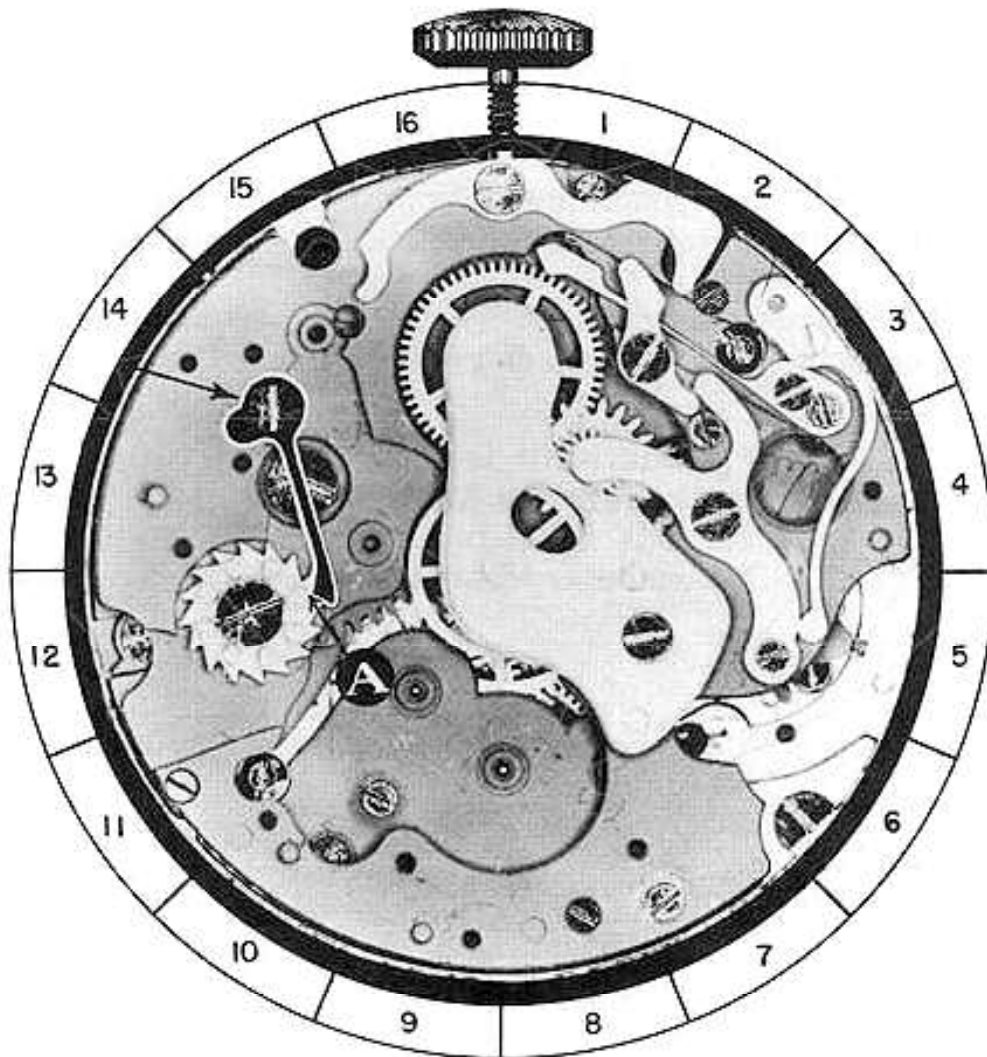

23-A

A. DISASSEMBLY PROCEDURE OF CASTLE WHEEL:

The castle wheel is held in place by fillister screw FS-10. When this screw is removed, the castle wheel can be lifted out of place.

(The shape of screw for this part is shown at bottom of page)

B. ASSEMBLY PROCEDURE OF CASTLE WHEEL:

Place castle wheel in its proper position on the plate, as shown on the photograph, with hole in castle wheel over stud on plate. Now replace fillister head screw FS-10 that holds castle wheel in place. After replacing screw, check to see that castle wheel pivots freely under the head of this screw.

C. FUNCTION OF CASTLE WHEEL:

The functions of the castle wheel are:

1. It prevents the flyback lever from being moved toward the center of the watch when the chronograph mechanism is engaged.
2. It disengages the brake lever from the seconds wheel.
3. It disengages the intermediary wheel from the seconds wheel.

REFERENCE: Flyback lever is Assembly 19.
Brake lever is Assembly 22.
Seconds wheel is Assembly 27.
Intermediary wheel is shown on page 14-C.

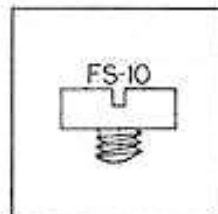

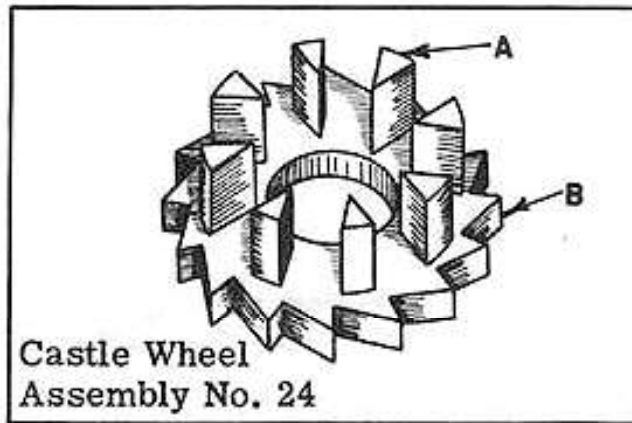

OILING

The castle wheel should be slightly moistened with oil at the following points:

1. The shoulder of screw on which castle wheel pivots.
2. The columns "A" at point of contact with the chronograph mechanism.
3. The ratchet teeth "B" on castle wheel.

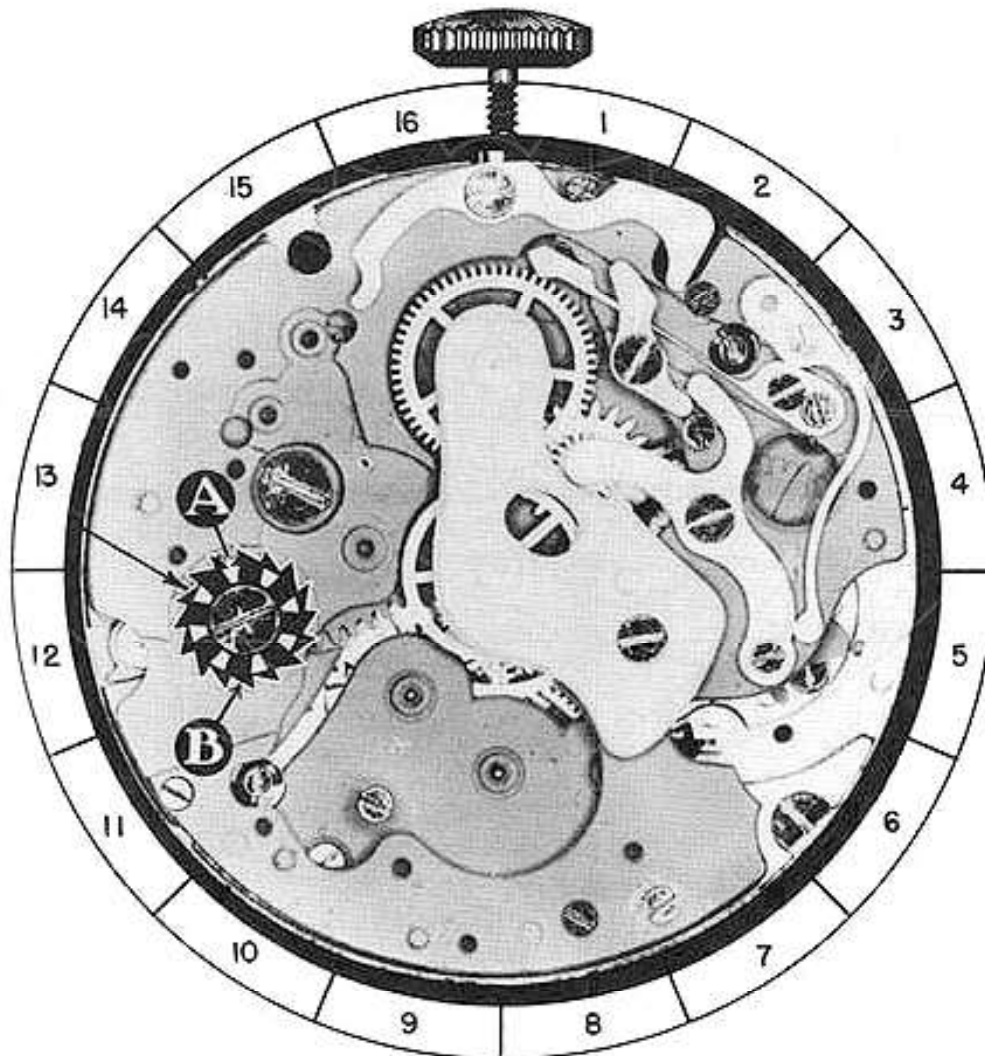

24-A

A. DISASSEMBLY PROCEDURE OF SECONDS WHEEL AND MINUTE REGISTER WHEEL BRIDGE:

This bridge is held in place by fillister screw FS-11 and steady pins. When this screw is removed, slide a finely-sharpened screwdriver under the bridge to loosen the bridge from plate. Now lift bridge straight up without tilting the bridge. Any tilting of bridge may bend or break the pivots on seconds wheel and minute register wheel.

(The shape of screw for this part is shown at bottom of page)

B. ASSEMBLY PROCEDURE OF SECONDS WHEEL AND MINUTE REGISTER WHEEL BRIDGE:

Place the bridge in its proper position on the plate with steady pins over proper holes in plate. Make sure that the pivots on the seconds wheel and minute register wheel are entering the jewels in bridge. Now press bridge down to proper place with back of tweezers, and replace fillister screw FS-11 which holds the bridge in its proper position.

C. HAZARDS IN ASSEMBLY OF SECONDS WHEEL AND MINUTE REGISTER WHEEL BRIDGE:

Caution: When replacing the bridge, check to see that pivots on seconds wheel and minute register wheel are entering jewel holes in the bridge. Failure to have these pivots in proper position may result in bending the pivots or chipping the jewels when the screw is replaced in the bridge.

D. FUNCTION OF SECONDS WHEEL AND MINUTE REGISTER WHEEL BRIDGE:

The function of the seconds wheel and minute register wheel bridge is to hold the seconds wheel and minute register wheel upright, so that these wheels can function properly.

REFERENCE: Minute register wheel is Assembly 26.
Seconds wheel is Assembly 27.

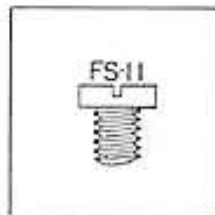

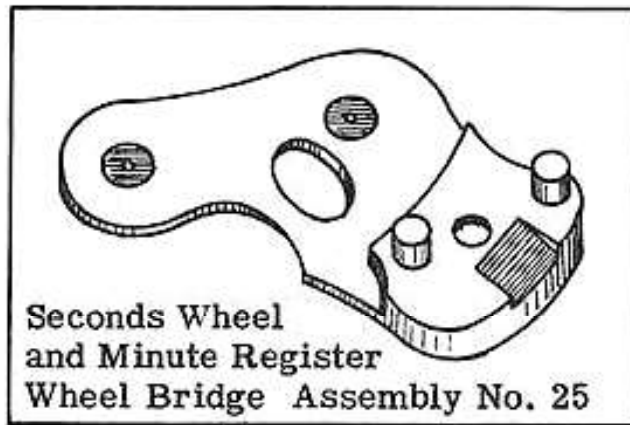

Seconds Wheel
and Minute Register
Wheel Bridge Assembly No. 25

OILING

The pivots in the jewels in this bridge should be oiled as you would properly oil the train pivots in a watch.

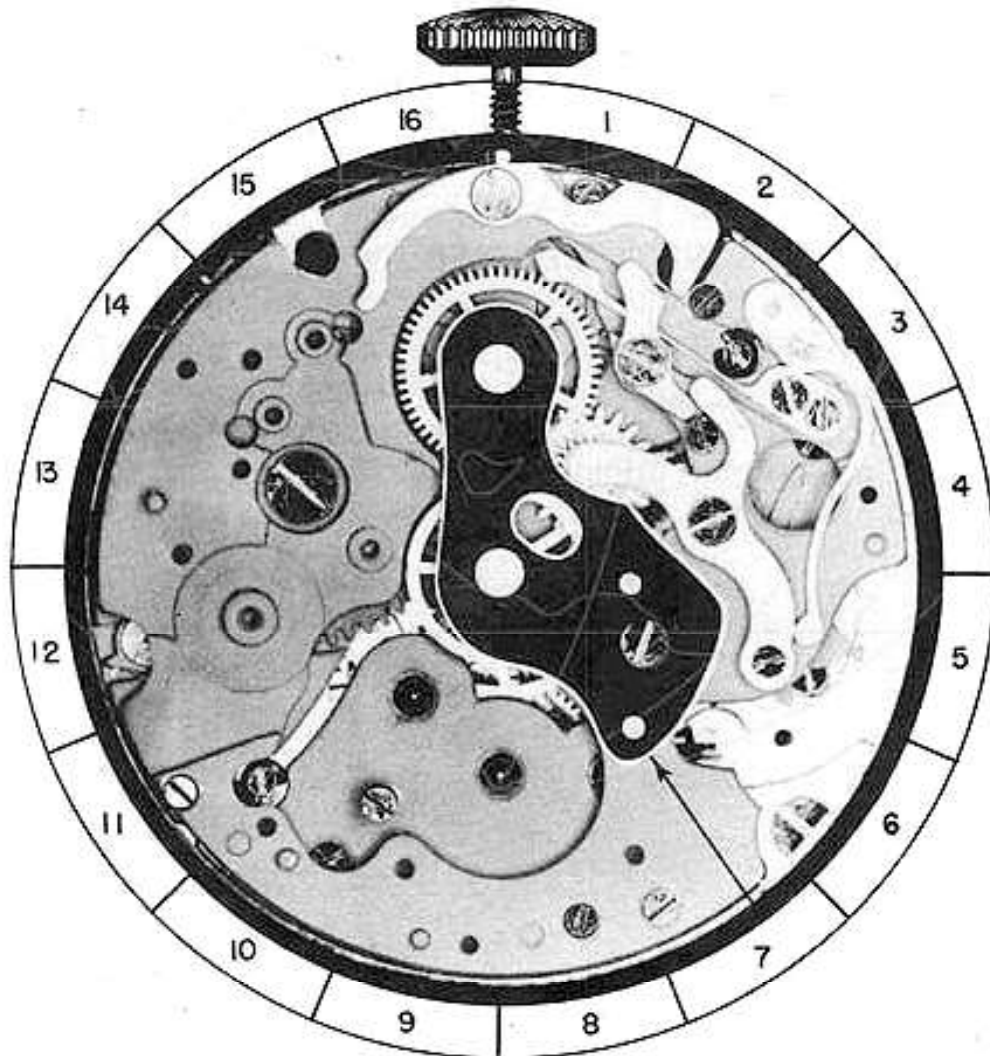

25-A

A. DISASSEMBLY PROCEDURE OF MINUTE REGISTER WHEEL:

Before removing the minute register wheel, check to see that the minute register pawl is not on top of minute register wheel. If it is on top of this wheel, move it away so that the minute register wheel can be lifted out of place without damaging the minute register pawl.

REFERENCE: Minute register pawl is Assembly 34.

B. ASSEMBLY PROCEDURE OF MINUTE REGISTER WHEEL:

Place the minute register wheel in its proper position on plate, as shown on photograph, with the long pivot "A" on wheel down in pivot hole in plate. Now check to see that the minute register pawl is not under the wheel. If the minute register pawl is beneath the minute register wheel, move it away and push wheel down, so that minute register pawl meshes into the teeth of minute register wheel.

C. FUNCTION OF MINUTE REGISTER WHEEL:

The function of the minute register wheel is to register the minutes that have elapsed, since the sweep second hand began to register. This is done by a hand being attached to the long post on the minute register wheel, indicating the minutes on the dial.

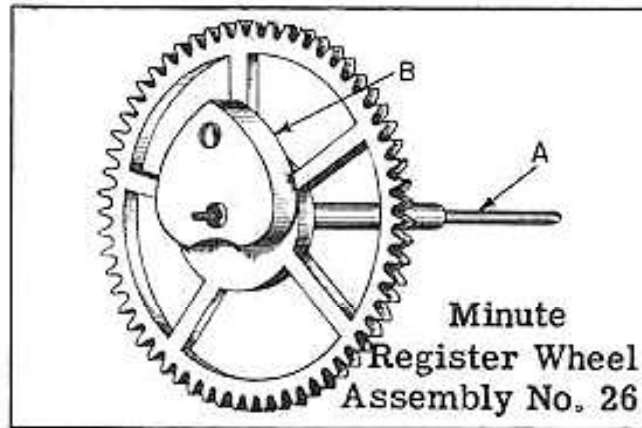

OILING

The top and bottom pivots on minute register wheel should be oiled after bridge for this part is placed in watch. Oil these pivots as you would properly oil the train pivots in a watch.

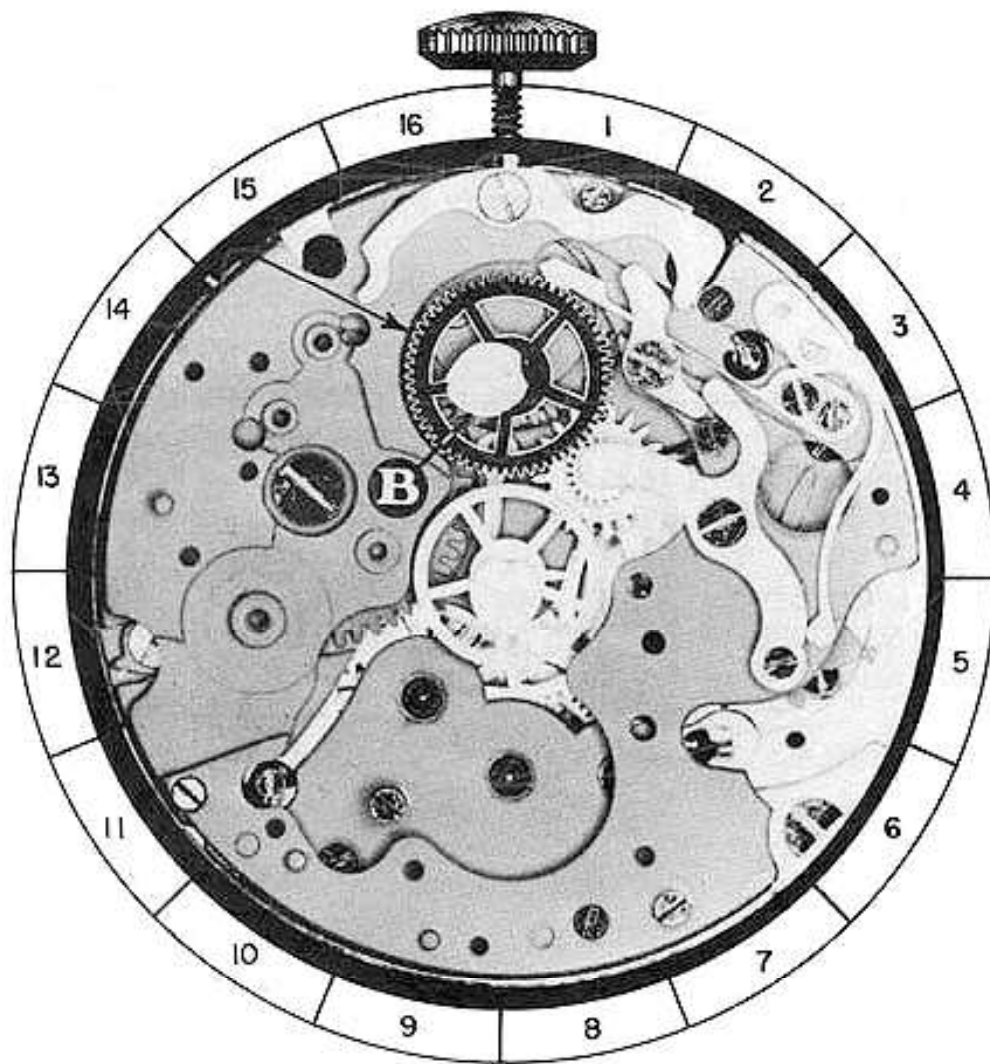

26-A

A. DISASSEMBLY PROCEDURE OF SECONDS WHEEL:

To remove the seconds wheel, simply lift it straight up out of place.

B. HAZARDS IN DISASSEMBLY OF SECONDS WHEEL:

When removing this wheel, be sure to lift wheel straight up. Do not tilt wheel as this may bend pivot on this wheel.

C. ASSEMBLY PROCEDURE OF SECONDS WHEEL:

Place the seconds wheel in the position shown in the photograph, with the long post "A" down in the hollow center pinion.

D. FUNCTION OF SECONDS WHEEL:

The function of seconds wheel is to register the seconds. This is done by a hand being attached to the long post or long pivot on seconds wheel registering seconds on the dial. The heart "B" on seconds wheel is used in returning the seconds wheel to a zero position.

REMARKS:

The seconds wheel is returned to a zero position by the flyback lever contacting the heart "B" on seconds wheel. The heart on this wheel is set eccentric. When the flat end "B" of flyback lever contacts the eccentric heart, it forces the heart to turn. The heart will turn until the flat end of flyback lever sets across the two lobes at top of heart. With the pressure equalized at these two points, it will turn no further and this would be a zero position.

REFERENCE: Flyback lever is Assembly 19.

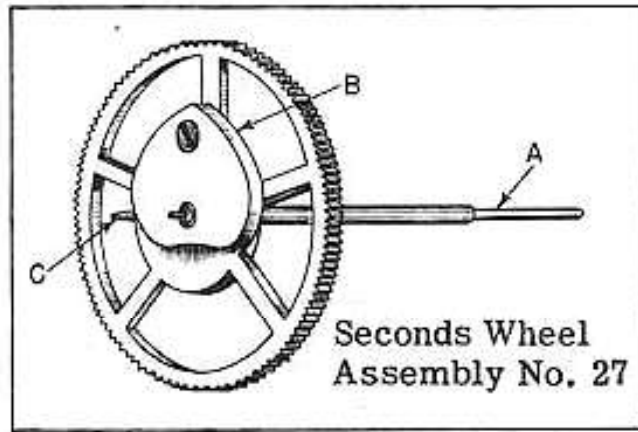

OILING

The top pivot on seconds wheel should be oiled after bridge for this part is placed in watch. The bottom pivot is not oiled.

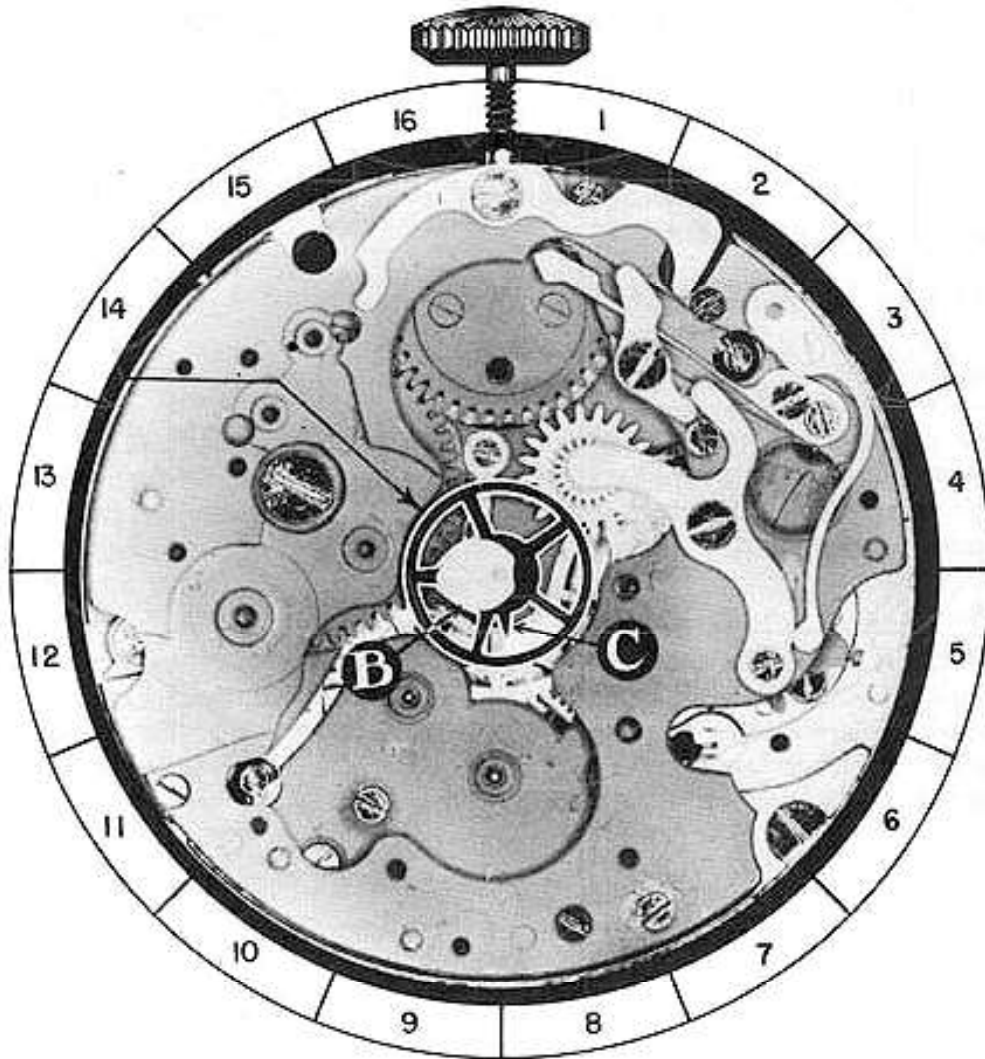

27-A

A. DISASSEMBLY PROCEDURE OF SECONDS WHEEL TENSION SPRING:

This spring is held in place by fillister screw FS-12. When this screw is removed; the spring will be free on the plate, and can be lifted out of place.

(The shape of screw for this part is shown at bottom of page)

B. HAZARDS IN DISASSEMBLY OF SECONDS WHEEL TENSION SPRING:

Care should be taken in removing this spring, as it is a very fine spring and can be easily bent or mutilated.

C. ASSEMBLY PROCEDURE OF SECONDS WHEEL TENSION SPRING:

Place the seconds wheel tension spring in its proper position on plate. Now replace fillister screw FS-12 that holds this spring in place. After screw is replaced, check to see that the end "A" of spring is not over hole for seconds wheel. This spring should fit right along the side of the hole. The "B" side of spring should face up.

D. FUNCTION OF SECONDS WHEEL TENSION SPRING:

The seconds wheel tension spring holds a tension on the seconds wheel, so that it turns with a smooth, even action, with no irregular jumping or jerking.

REFERENCE: Seconds wheel is Assembly 27.

REMARKS:

After the watch is completely assembled, check to see that the sweep seconds hand turns evenly, with no irregular jumping or jerking. If there is any irregular jumping or jerking of sweep second hand, the seconds wheel tension spring will have to be bent to increase the tension on seconds wheel. This will eliminate any irregular movement of the hands.

Also, care should be taken that the seconds wheel tension spring does not hold too much tension on seconds wheel, as this would cause seconds wheel to be hard to turn and may stop the watch. The seconds wheel tension spring should just hold enough tension on seconds wheel to perform its function as described above.



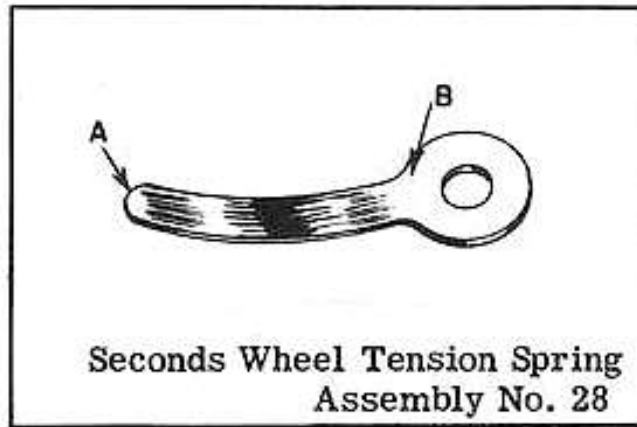

OILING

Seconds wheel tension spring should not be oiled.

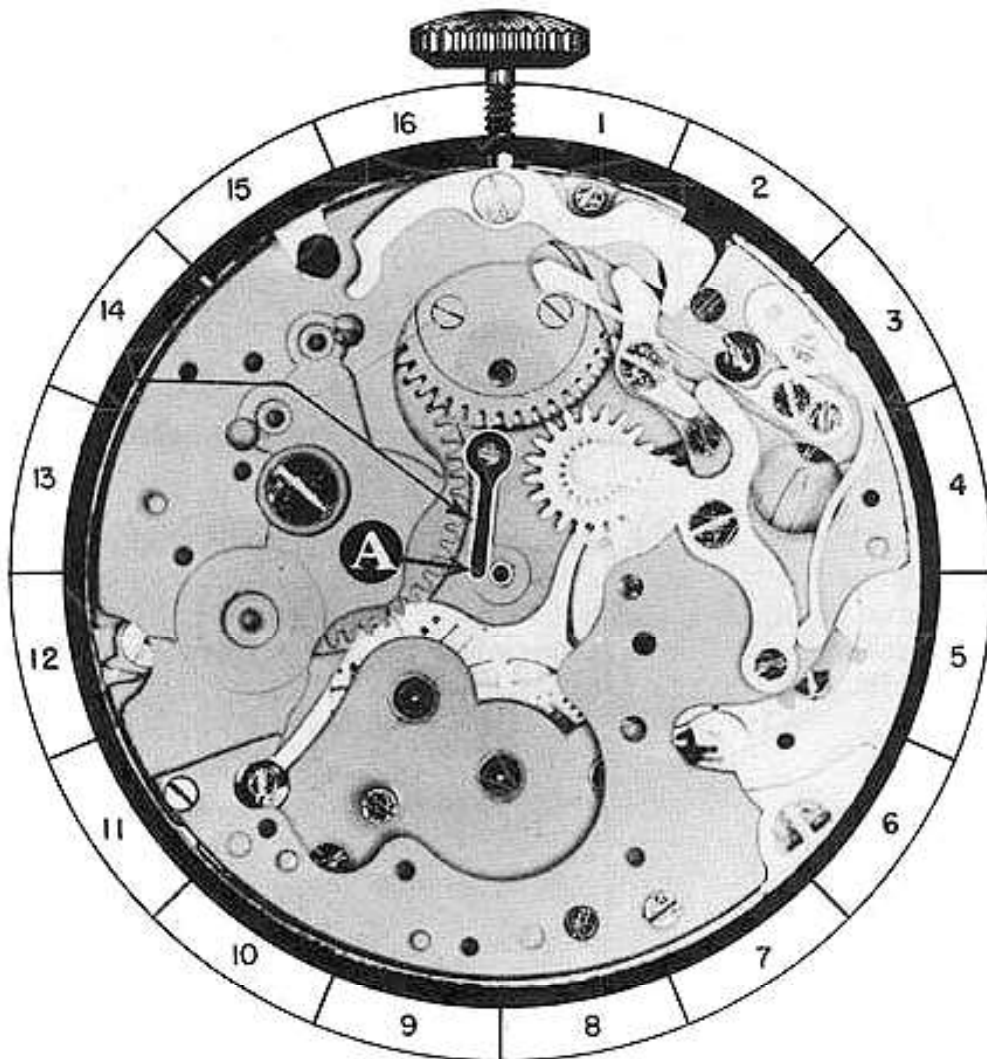

28-A

A. DISASSEMBLY PROCEDURE OF INTERMITTENT LEVER SPRING:

This spring is held in place by a beveled countersink screw BS-5 and a stud. When this screw is removed, spring should be free and can be lifted out of place.

(The shape of screw for this part is shown at bottom of page)

B. ASSEMBLY PROCEDURE OF INTERMITTENT LEVER SPRING:

Place the intermittent lever spring in its proper position on plate with hole "B" in spring over stud on plate. Now replace beveled countersink screw BS-5 that holds this spring in place.

C. FUNCTION OF INTERMITTENT LEVER SPRING:

The function of the intermittent lever spring is to hold the intermittent wheel in a position to contact the dart tooth.

REFERENCE: Intermittent wheel is Assembly 31.
Seconds wheel dart tooth is Assembly 27-C.

REMARKS:

When adjusting springs for proper tension, it is good to follow this policy as a general rule.

1. A spring should just hold enough tension on a part to perform its function properly.
2. Any excess tension on a part in a chronograph mechanism will cause the chronograph to be harder to work, also causing more wear etc.

Of course, the amount of pressure the spring should hold on a part is determined in the factory, because of this it is seldom that you would have to adjust a spring. In many cases however, you may have to make one of these springs, and the above rules should aid you in setting the proper tension.



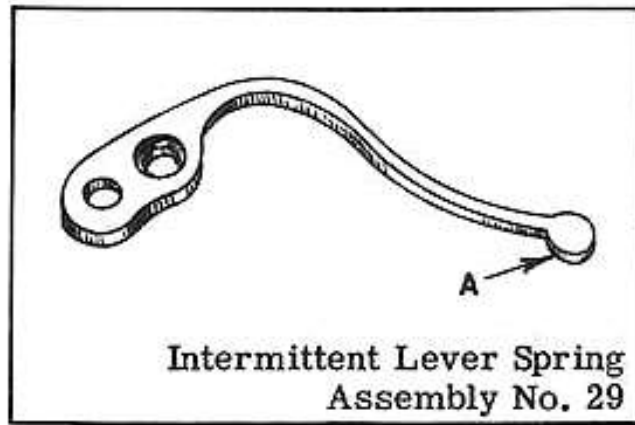

OILING

End "A" of intermittent lever spring should be slightly moistened with oil at point of contact with intermittent lever.

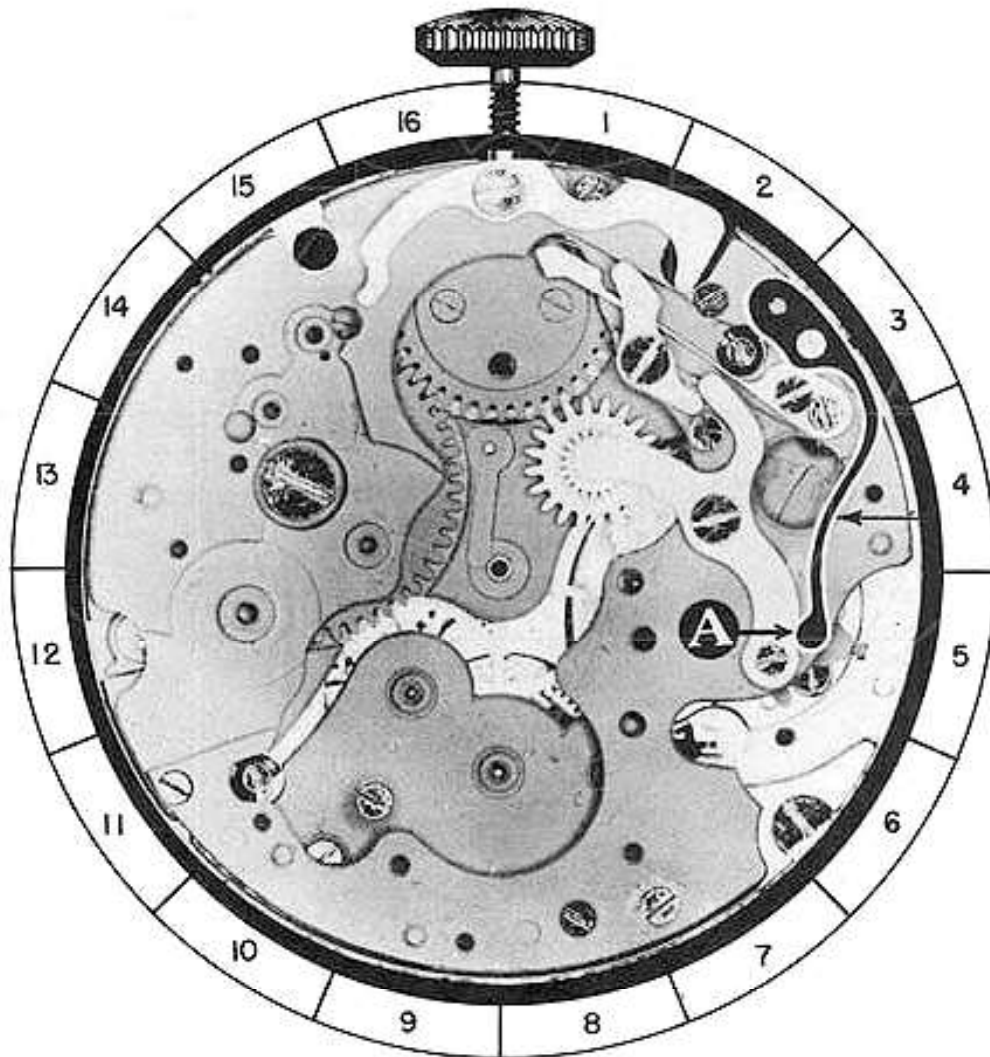

29-A

A. DISASSEMBLY PROCEDURE OF INTERMITTENT LEVER:

The intermittent lever is held in place by shouldered screw SS-12 and an eccentric stud. The intermittent lever pivots on this stud. When screw SS-12 is removed the intermittent lever can be lifted out of place.

(The shape of screw for this part is shown at bottom of page)

B. ASSEMBLY PROCEDURE OF INTERMITTENT LEVER:

Place intermittent lever in its proper position on plate with pin "A" on intermittent lever in hole of intermittent wheel. Also, place hole "B" in intermittent lever on eccentric stud in plate. Now replace shouldered screw SS-12. After shouldered screw is replaced, check intermittent lever to see that it pivots freely under head of this screw. Also, at this point, check the intermittent wheel to see that it is not binding. This wheel must turn freely.

REFERENCE: Intermittent wheel is Assembly 31.

C. FUNCTION OF INTERMITTENT LEVER:

The function of the intermittent lever is to engage and disengage the intermittent wheel with the seconds wheel dart tooth.

REFERENCE: Seconds wheel dart tooth is Assembly 27-C.

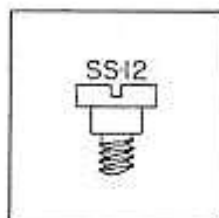

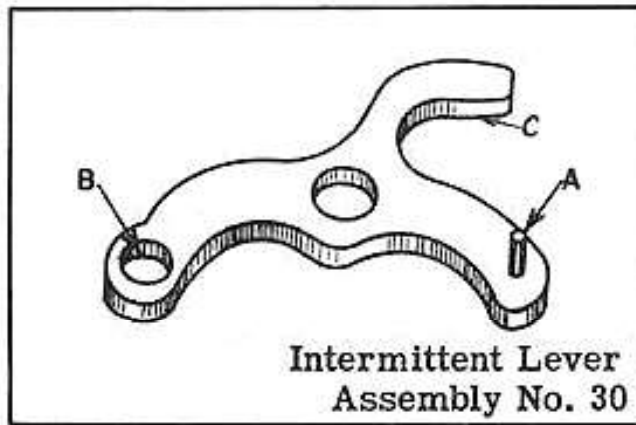

OILING

The intermittent lever should be slightly moistened with oil at the following points:

1. The shoulder of screw that lever pivots on.
2. Point "C" that contacts intermittent connecting lever.

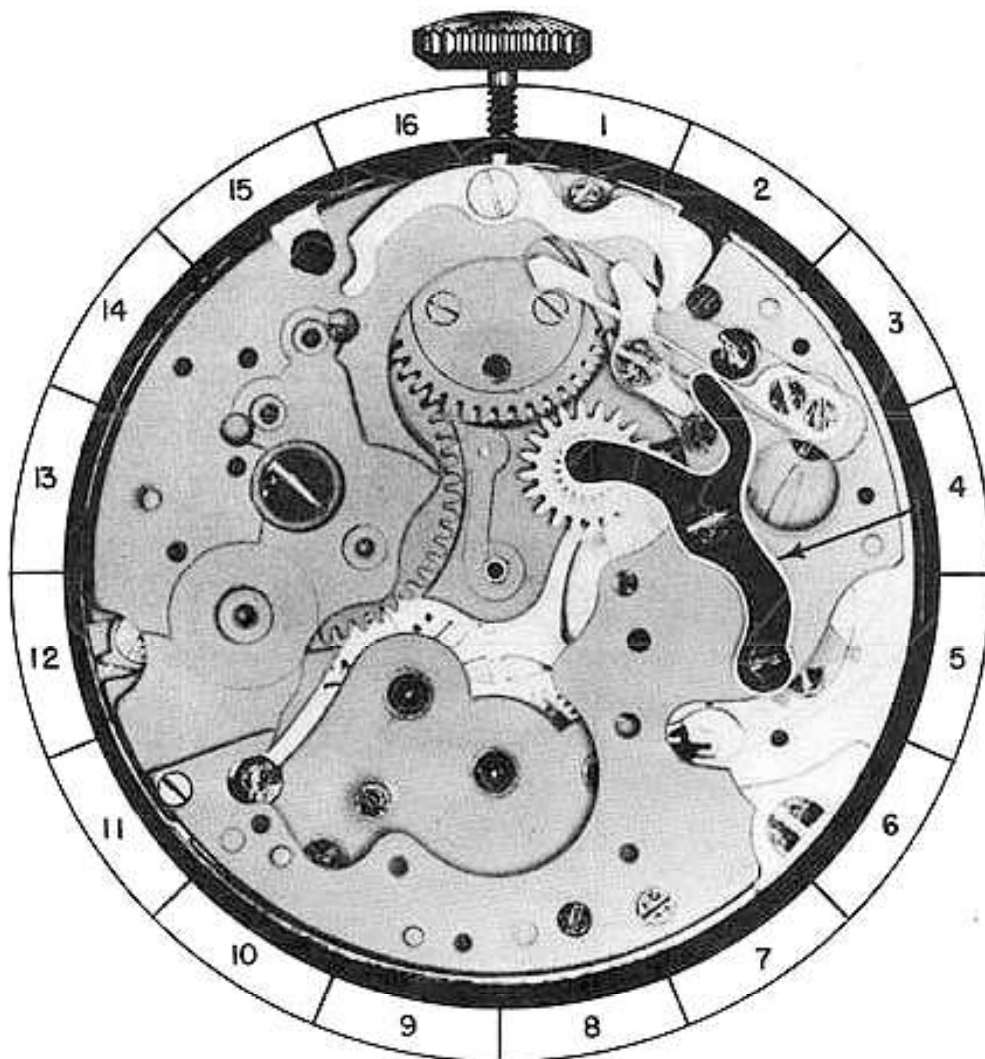

30-A

A. DISASSEMBLY PROCEDURE OF INTERMITTENT WHEEL:

After the intermittent lever has been removed, the intermittent wheel will be free on the plate, and can be lifted out of place.

B. ASSEMBLY PROCEDURE OF INTERMITTENT WHEEL:

Place the intermittent wheel on the plate in its proper position, as shown in the photograph. The intermittent lever holds this wheel in its proper position.

C. FUNCTION OF INTERMITTENT WHEEL:

The function of the intermittent wheel is to transfer the power from the seconds wheel dart tooth to the minute register wheel.

REMARKS:

When the seconds wheel and minute register wheel are being returned to a zero position, the intermittent wheel must be disengaged from the path of the dart tooth on seconds wheel. The dart tooth cannot be permitted to contact the intermittent wheel at this time, as it may prevent the seconds wheel and minute register wheel from returning to a zero position.

REFERENCE: Minute register wheel is Assembly 26.
Seconds wheel is Assembly 27.
Seconds wheel dart tooth is Assembly 27-C.
Intermittent lever is Assembly 30.

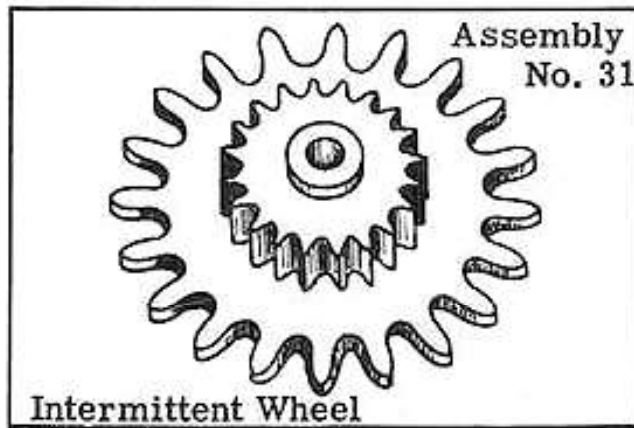

OILING

The intermittent wheel should not be oiled.

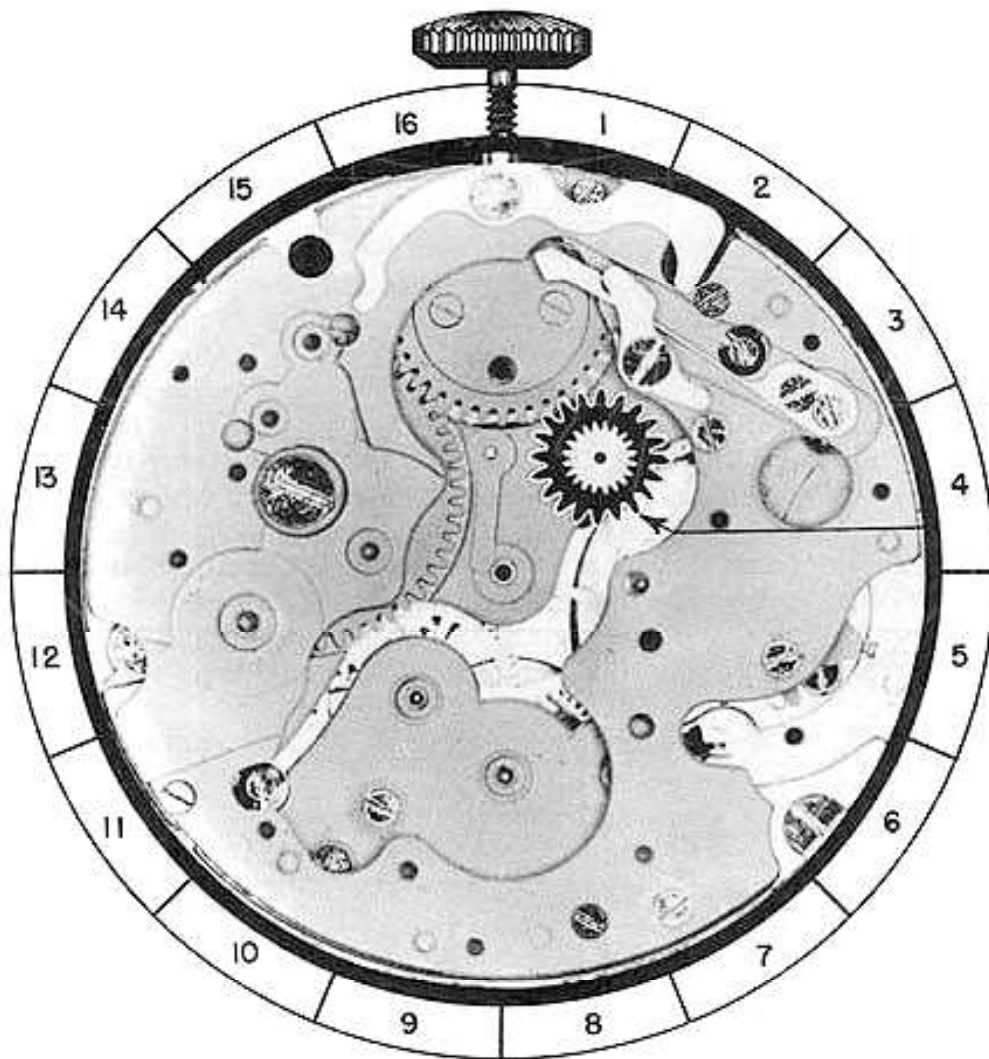

31-A

A. DISASSEMBLY PROCEDURE OF INTERMITTENT CONNECTING LEVER:

The intermittent connecting lever is held in place by shouldered screw SS-13. When this screw is removed, the intermittent connecting lever can be lifted out of place. Care should be taken, when removing the intermittent connecting lever, that no damage is done to the minute register pawl. A slight slip of the screw-driver, when removing the screw on connecting lever, may ruin the minute register pawl.

(The shape of screw for this part is shown at bottom of page)

B. ASSEMBLY PROCEDURE OF INTERMITTENT CONNECTING LEVER:

Place the intermittent connecting lever in its proper position on plate, as shown in photograph. Now, replace shouldered screw SS-13. When replacing screw, check to see that screw-drivers are properly sharpened, because a slip of the screw-driver may damage the minute register pawl. After screw is replaced, check to see that intermittent connecting lever pivots freely under head of this screw.

C. FUNCTION OF INTERMITTENT CONNECTING LEVER:

The function of the intermittent connecting lever is to transfer the power from the push piece for setting back to zero to the intermittent lever.

REFERENCE: Seconds wheel dart tooth is Assembly 27-C.
Intermittent wheel is Assembly 31.
Minute register pawl is Assembly 34.

REMARKS:

The intermittent connecting lever works somewhat like a sea-saw. When end "A" of connecting lever is pushed toward center of the watch, end "B" is forced away from the center of the watch. When end "B" is forced away from the center of the watch, it contacts the intermittent lever and forces the intermittent lever and intermittent wheel away from the center of the watch. A few minutes spent in observing these parts will help you to more fully understand the function of this part.



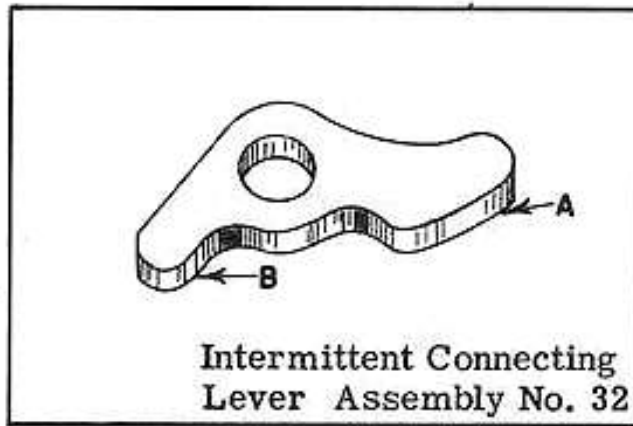

OILING

The intermittent connecting lever should be slightly moistened with oil at these points:

1. The shoulder of screw that lever pivots on.
2. End "A" that contacts push piece for setting back to zero.

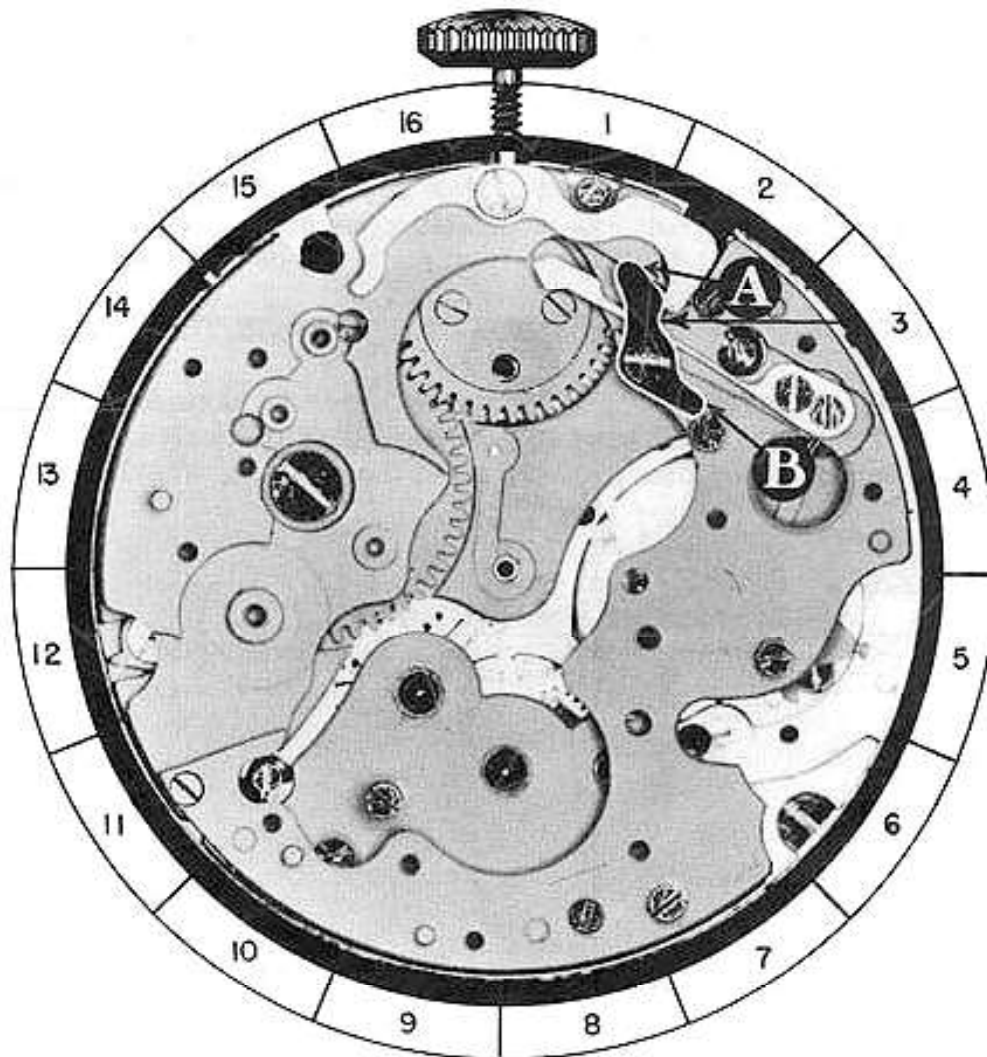

32-A

A. DISASSEMBLY PROCEDURE OF PUSH PIECE FOR SETTING BACK TO ZERO:

This push piece is held in place by a shouldered screw SS-14, and pivots under the head of this screw. When screw is removed, the push piece will be free on the plate and can be lifted out of place.

(The shape of screw for this part is shown at bottom of page)

B. HAZARDS IN DISASSEMBLY OF PUSH PIECE FOR SETTING BACK TO ZERO:

Care should be used in removing this part, due to the nearness of the minute register pawl. Make sure that the screwdriver is correctly sharpened, as a slip with the screwdriver at this point may damage or ruin the minute register pawl.

REFERENCE: Minute register pawl is Assembly 34.

C. ASSEMBLY PROCEDURE OF PUSH PIECE FOR SETTING BACK TO ZERO:

Place push piece for setting back to zero in its proper position on the plate, as shown in photograph. Now replace shouldered screw SS-14 that holds this part in place. After screw is replaced, check to see that push piece pivots freely under head of this screw.

D. FUNCTION OF PUSH PIECE FOR SETTING BACK TO ZERO:

The function of the push piece for setting back to zero, when pushed, is to force the flyback in towards the center of the watch. Also it disengages the intermittent wheel from the seconds wheel dart tooth.

REFERENCE: Flyback lever is Assembly 19.
Intermittent wheel is Assembly 31.
Seconds wheel dart tooth is Assembly 27-C.

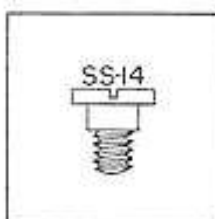

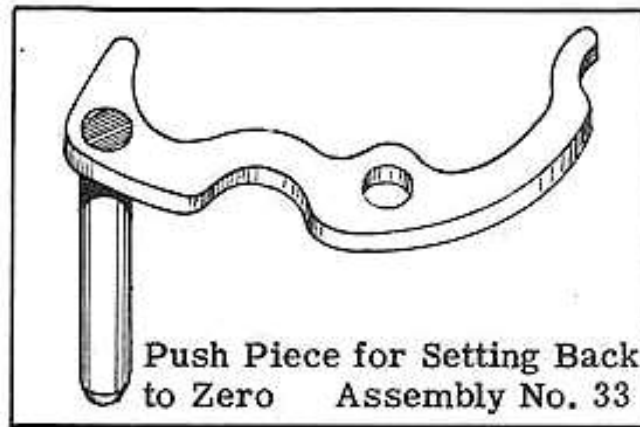

OILING

The shoulder of screw that push piece for setting back to zero pivots on should be slightly moistened with oil.

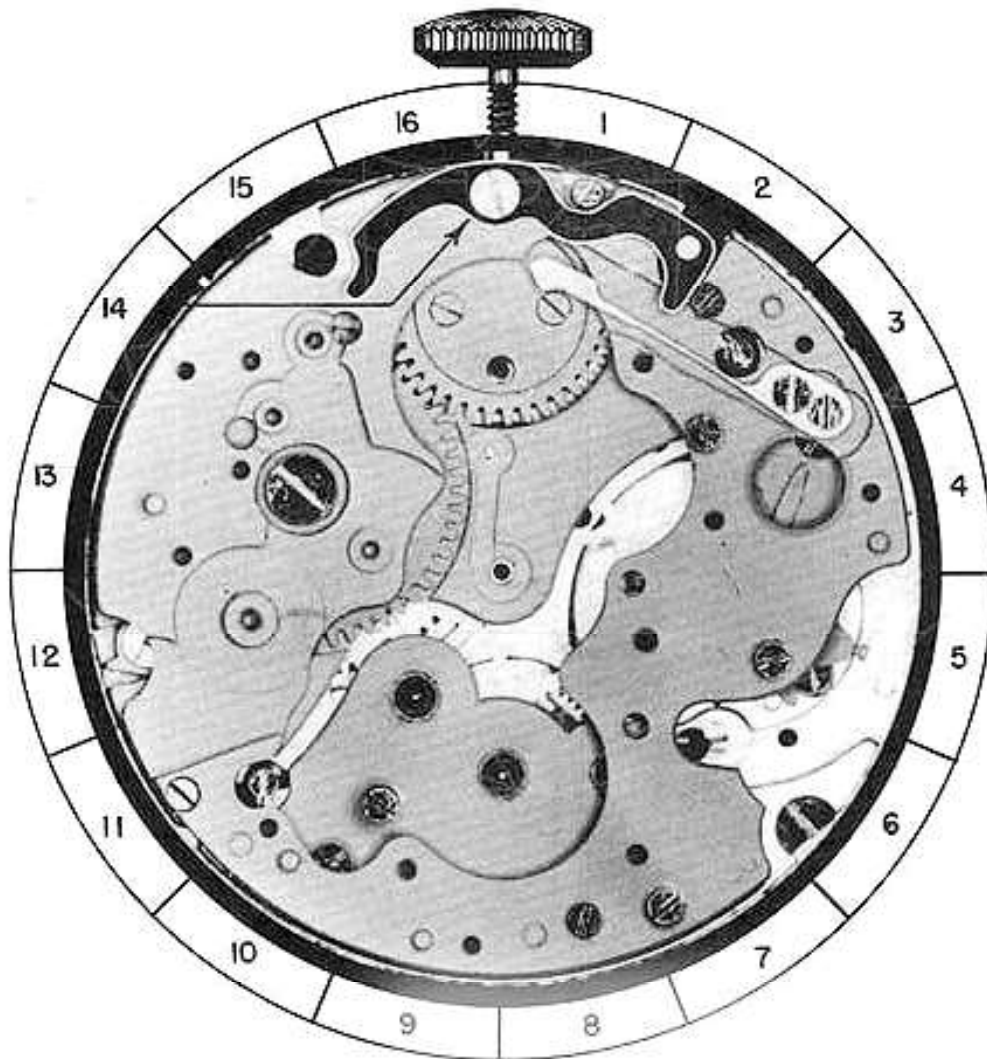

33-A

A. DISASSEMBLY PROCEDURE OF MINUTE REGISTER PAWL:

The minute register pawl fits over an eccentric stud and is held in place by a fillister head screw FS-13. After this screw is removed, the pawl can be lifted from the eccentric stud and free from watch. The position of fillister head screw FS-13 is shown in photograph.

(The shape of screw for this part is shown at bottom of page)

B. HAZARDS IN DISASSEMBLY OF MINUTE REGISTER PAWL:

The blade on the minute register pawl is very thin and delicate and can easily be bent or ruined, much care should be used in removing this part.

C. ASSEMBLY PROCEDURE OF MINUTE REGISTER PAWL:

Place the pawl in position on plate, with hole "A" in the pawl over eccentric stud. Now replace fillister head screw FS-13 that holds this pawl in place.

D. HAZARDS IN ASSEMBLY OF MINUTE REGISTER PAWL:

Handle this pawl very carefully when replacing it, as the blade on this pawl is very delicate and can be easily bent or ruined. End "B" of the pawl must be highly polished as any pits or rust at this point will cause the pawl not to function properly.

E. FUNCTION OF MINUTE REGISTER PAWL:

The functions of the minute register pawl are:

1. It holds a tension on the minute register wheel, so this wheel moves exactly one tooth each time it is moved.
2. It holds minute register wheel stationary, so that a bump cannot alter position of this wheel until it is moved mechanically.

REFERENCE: Minute register wheel is Assembly 26.

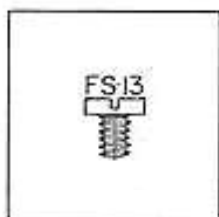

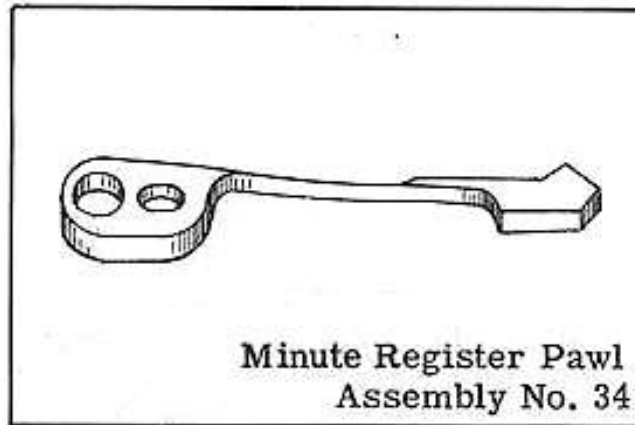

OILING

The minute register pawl should not be oiled.

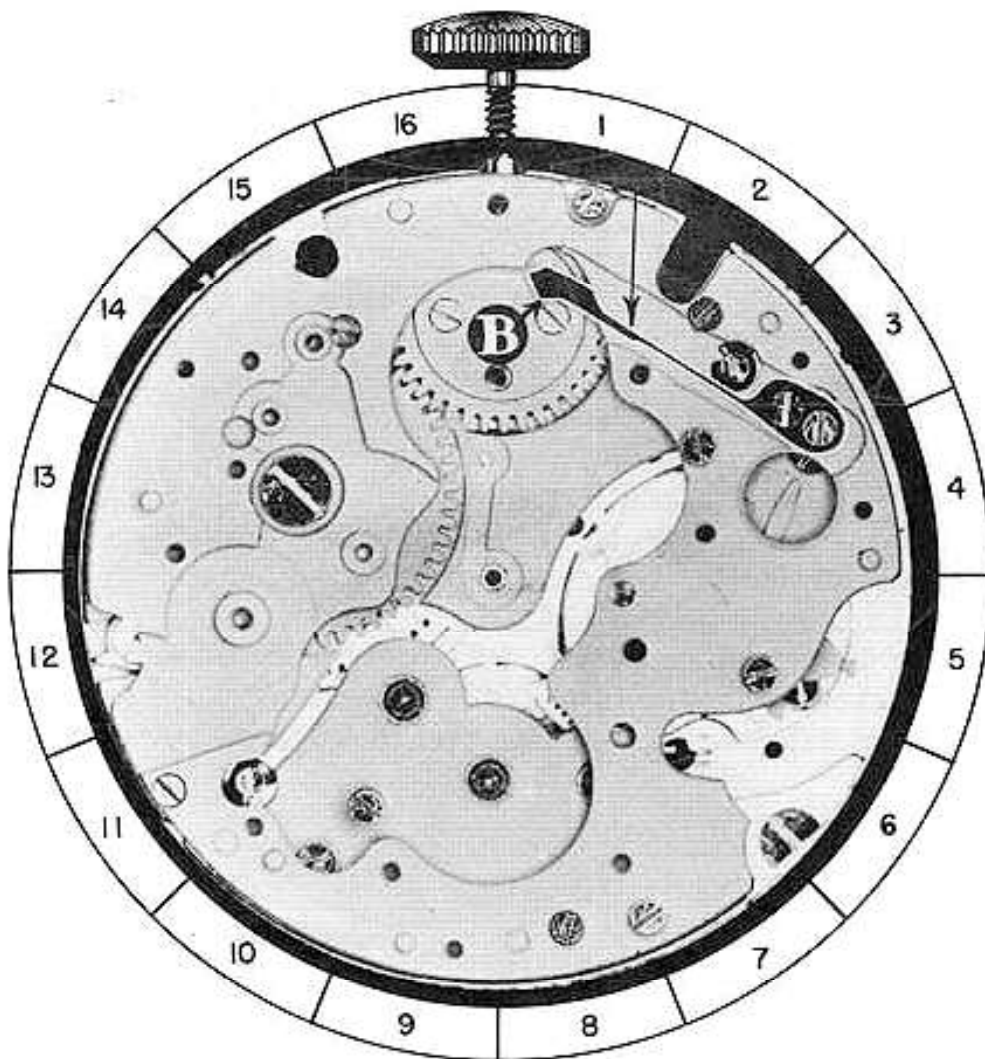

34-A

PART NO. 35

A. DISASSEMBLY PROCEDURE OF CHRONOGRAPH ASSEMBLY PLATE:

To remove this plate, remove fillister head screws FS-14, FS-15 and FS-16. The positions of these screws are shown in photograph. Now, slide a finely-sharpened screwdriver under assembly plate, loosening it from the watch. This will permit the plate to be lifted out of place.

(The shape of screws for this part is shown at bottom of page)

B. HAZARDS IN DISASSEMBLY OF CHRONOGRAPH ASSEMBLY PLATE:

In removing this plate from the watch use the screwdriver carefully so as not to mar the plates.

C. ASSEMBLY PROCEDURE OF CHRONOGRAPH ASSEMBLY PLATE:

Place this plate in its proper position on the watch, as shown in the photograph. Replace the three fillister head screws FS-14, FS-15 and FS-16, that hold this plate to the watch. The positions of these screws are shown in photograph.

D. PURPOSE OF THIS ASSEMBLY PLATE:

The purpose of this plate is to make it possible for the chronograph mechanism to be removed as one unit. You do not have to disassemble the chronograph mechanism, to get at the watch movement. All that is necessary is, to remove the fillister head screws FS-14, FS-15 and FS-16, and lift the chronograph mechanism up from the watch. This leaves the movement exposed, permitting you to work on any part of it.

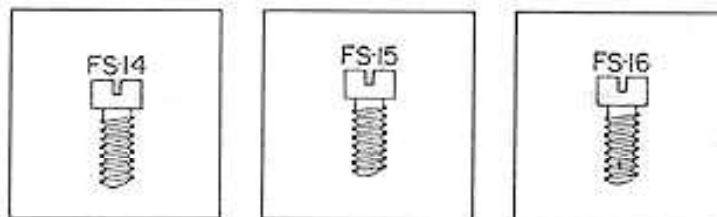

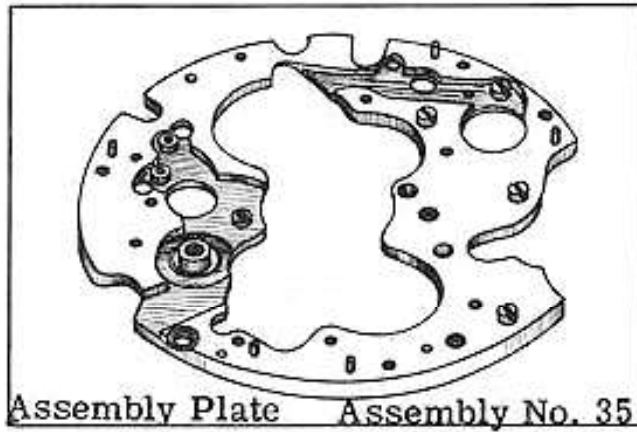

Assembly Plate Assembly No. 35

The assembly plate should not be oiled.

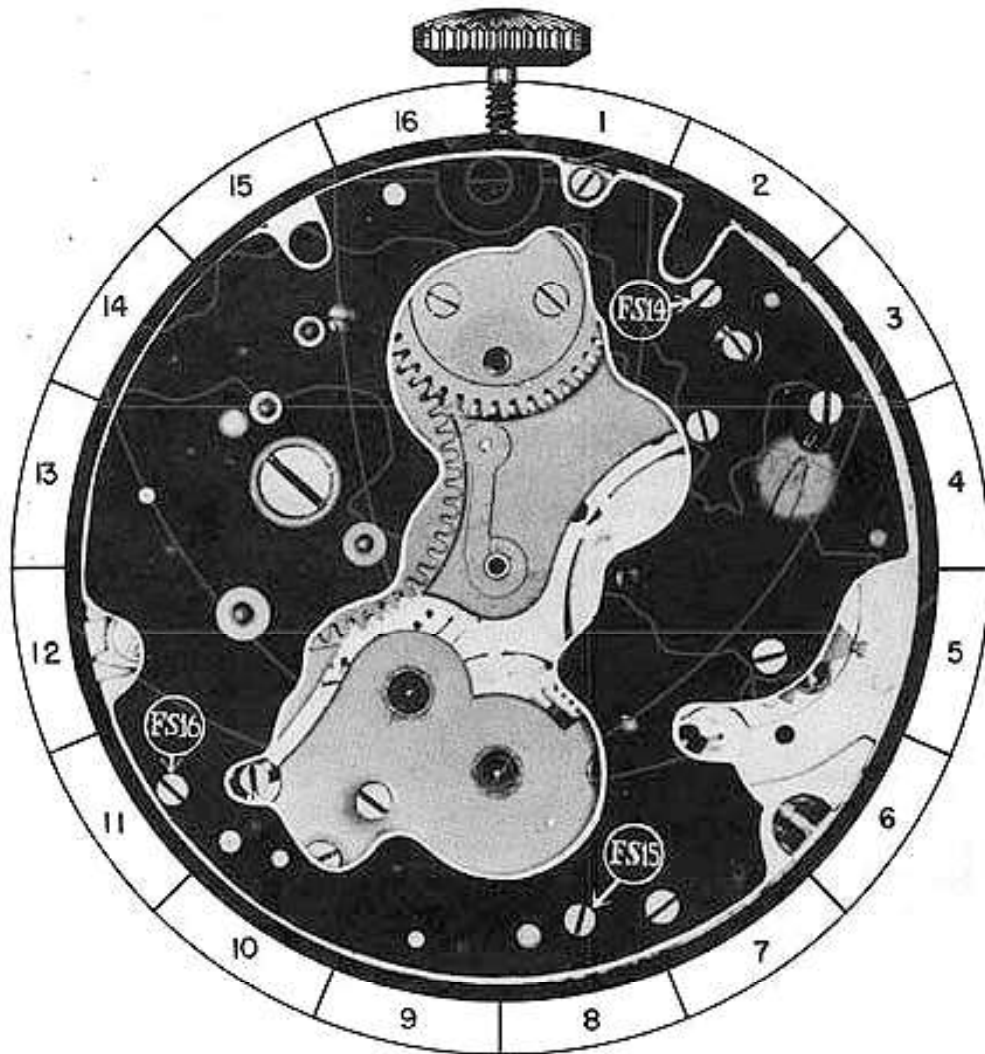

35-A

FUNCTIONAL RESULTS

After completely assembling chronograph with exception of the dial and hands, place the chronograph in front of you, pendant up with the dial side facing you.

1. Push the button to the left of the pendant, hold in this position and check the following:

(Make sure that the chronograph mechanism is not engaged, otherwise, button cannot be pushed.)

- A. Check to see that hour register wheel returns to a zero position.

CORRECTION: The following errors can prevent this wheel from returning to a zero position:

1. The hour register wheel binding and not turning freely.
2. Incorrect adjustment of eccentric stud ES-3.
(See adjustment of eccentric studs.)

- B. When the hour flyback lever has returned the hour register wheel to a zero position, check to see that end of pawl lies directly in center of two teeth on the hour register wheel. Failure to have this pawl properly adjusted will result in hour register hand moving after flyback lever moves away from the heart.

2. Release the button and check the following:

- A. Check to see that hour flyback lever returns to its original position.

CORRECTION: The following errors could prevent hour flyback lever from returning to its original position:

1. Hour flyback lever spring not holding a strong enough tension on hour flyback lever.
2. The hour flyback lever binding and not pivoting freely.

- B. Check to see that the intermediary hour wheel is properly engaged with the hour register wheel.

CORRECTION: If these wheels are not properly engaged, the following errors could cause this:

1. The hour pivoted detent spring being too weak and not holding enough tension on hour pivoted detent.
2. Hour pivoted detent binding and not pivoting freely.
3. Improper adjustment of eccentric studs.
(See adjustment of eccentric studs.)

(Continued on next page)

FUNCTIONAL RESULTS
(Continued)

3. Now place dial and hands on the chronograph and turn chronograph over, pendant up with back of watch facing you. Push button to the right of the pendant, hold in this position, and check the following:

(Make sure that the chronograph mechanism is not engaged, otherwise, button cannot be pushed.)

- A. Check to see that seconds wheel and minute register wheel return to a zero position. Also check on the dial to see that the hands connected to these wheels return to a zero position.

CORRECTION: The following errors could prevent these wheels or hands from returning to a zero position:

1. Loose hands or hands not being set correctly.
2. The minute register wheel or the seconds wheel binding and not turning freely.

- B. Check to see that end of minute register pawl lies directly in center of two teeth on minute register wheel when this wheel is at a zero position.

CORRECTION: The following errors could cause the minute register pawl not to lie directly between two teeth on minute register wheel:

1. Minute register wheel binding and not turning freely.
2. Intermittent wheel binding and not turning freely.
3. Improper adjustment of eccentric studs could prevent the pawl from setting between two teeth on minute register wheel.
(See adjustment of eccentric studs.)

4. Release the button and check the following:

- A. Check to see that flyback lever returns to its original position.

CORRECTION: The following errors could prevent flyback lever from returning to its original position:

1. Flyback lever spring not holding enough tension on flyback lever.
2. Flyback lever binding and not pivoting freely.

5. Push the button at left of the pendant, release it, and check the following:

- A. Check depth of intermediary wheel teeth with seconds wheel teeth.

CORRECTION: The following errors could prevent correct depth of these teeth:

(Continued on next page)

FUNCTIONAL RESULTS
(Continued)

1. Chronograph pivoted detent spring not holding enough tension on chronograph pivoted detent.
2. Chronograph pivoted detent not turning freely.
3. Improperly adjusted eccentric studs could prevent the proper depthing of these wheels.
(See adjustment of eccentric studs.)

B. Check depthing of seconds wheel dart tooth with intermittent wheel teeth.

CORRECTION: The following errors could prevent proper depthing of dart tooth and intermittent wheel teeth:

1. Intermittent lever not turning freely on post in plate.
2. Intermittent lever spring not holding proper tension on intermittent lever.
3. Improper adjustment of eccentric studs can prevent proper depthing of these parts.
(See adjustment of eccentric studs.)

REMARKS:

If the depthing of the intermittent wheel teeth with the seconds wheel dart tooth is deep, the minute register wheel may move two teeth, each time the seconds wheel makes one revolution. If the depthing is shallow, it may cause the minute register wheel not to move a full tooth, and will not register the minutes on the dial.

C. Check to see that seconds hand moves forward in a steady manner with no irregular jumping or jerking.

CORRECTION: This irregular movement of the seconds hand is usually caused by the seconds wheel tension spring not holding enough tension on seconds wheel.

6. Push the button at left of pendant a second time. Release it and check the following:

A. Check to see that brake lever is in contact with the seconds wheel.

CORRECTION: The following errors could prevent brake lever from contacting seconds wheel:

1. Brake lever not turning freely under head of screw.
2. Brake lever spring not holding enough tension on brake lever.

REMARKS:

When the flyback lever is forced in toward the center of the watch and held at this position, check the seconds wheel and minute register wheel to see if either of these wheels will turn. The minute register wheel should turn slightly at this point, but the seconds wheel should be held very tight by the flyback lever. It is most essential for the seconds wheel to be held stationary by the flyback lever at a zero position. In the case of the minute register wheel, it does not have to be held absolutely stationary by the flyback lever, as the minute register pawl will serve this purpose. The only thing that the minute register wheel should be checked for is to see that the minute register wheel will not turn far enough to one side or to the other to let the minute register pawl drop into another tooth. This will assure that the minute register wheel will always be brought back to a zero position.

The advantage in having the minute register wheel turn slightly when the flyback lever is brought into the center of the watch is that if there is any wear in these parts, the seconds wheel and minute register wheel will still return to a zero position.

THE TACHOMETER

- A-B. The tachometer scales "A" and "B" are used to indicate the speed of an object in miles per hour. These tachometer scales can only indicate the average speed of an object traveling over a course of a measured mile.

METHOD OF USING A TACHOMETER

Start the chronograph sweep second hand at the exact moment the object starts to travel the measured distance of one mile. When the object has traveled the course of one mile, stop the chronograph sweep second hand. The point on the tachometer scales "A" or "B", over which the sweep second hand stopped, will indicate the average speed of the object in miles per hour. Read the tachometer scales as follows:

1. If the sweep second hand has not completed one revolution when stopped, take the reading on the outer scale "A" on the dial.
2. If the sweep second hand has completed one revolution, and started on the second revolution when stopped, take the reading on the outer spiral of the scale "B".
3. If the sweep second hand has completed two revolutions and has started on the third revolution when stopped, take the reading on the inner spiral of the scale "B".

SECOND HAND

- C. The second hand indicates the passing of seconds and should move one space each second. One complete revolution of the hand denotes the passage of one minute. This hand is independent of the chronograph mechanism, and continues to register the seconds as long as the watch is running.

SPLIT SECOND SCALE

- D. This scale is divided into 300 divisions, each indicating $1/5$ of a second. Every fifth division is marked with extra long lines, denoting one second.

The main purpose of this scale is to measure a fraction of a second accurately.

MINUTE REGISTER

- E. The minute register hand indicates on the dial the number of minutes that have elapsed since the beginning of the registration of the sweep second hand. One complete revolution of the minute register hand indicates the passage of 60 minutes.

HOUR REGISTER

- F. The hour register hand indicates on the dial the number of hours that have elapsed since the beginning of the registration of the sweep second hand. Each number on the scale denotes one hour. One complete revolution of the hour register hand indicates that 12 hours have elapsed. This hand will register the hours as long as the chronograph mechanism is in operation.

THE CHRONOGRAPH DIAL

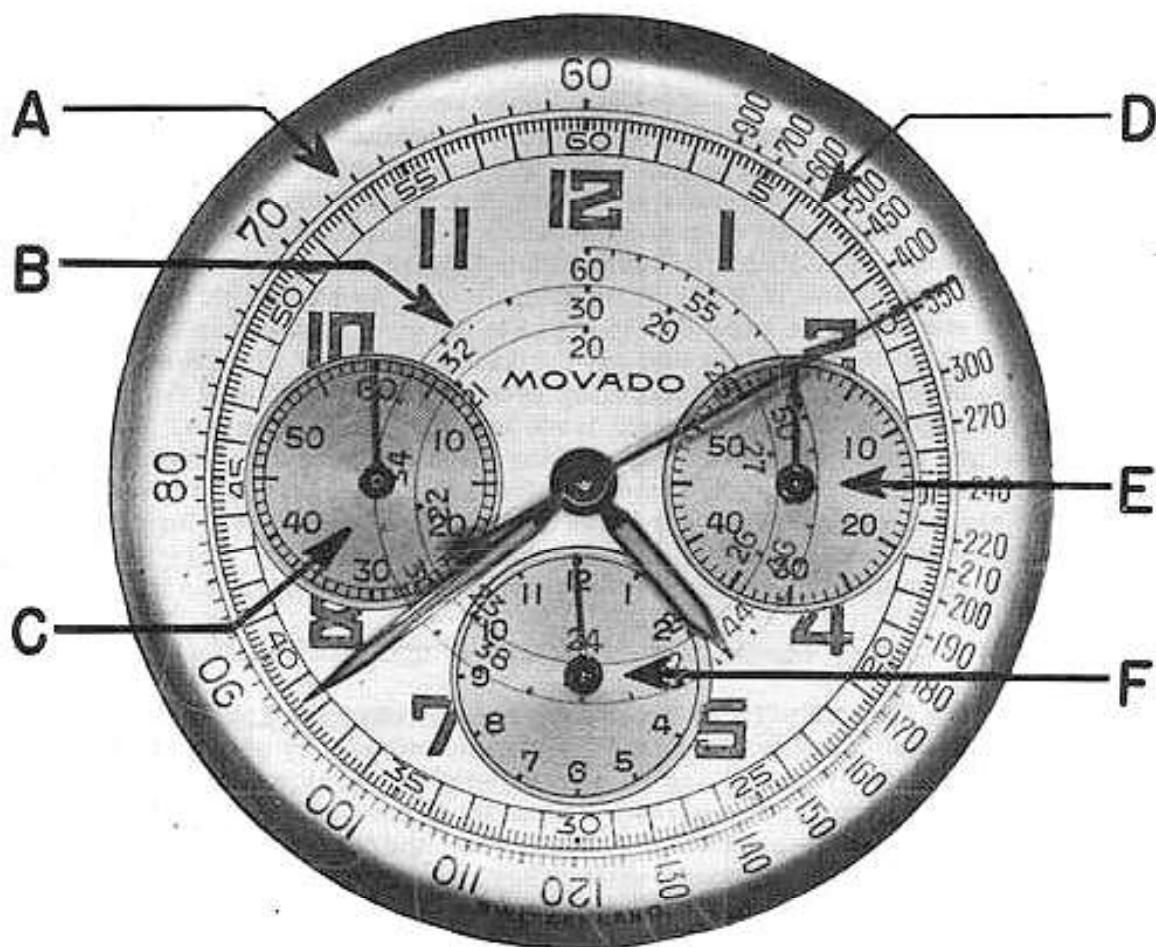

SETTING THE HANDS CORRECTLY ON A CHRONOGRAPH

After the chronograph is completely assembled and in working condition, replace the dial and the hour, minute, and second hand, as you would on a regular watch. Do not replace the sweep second hand, the minute register hand, or the hour register hand at this time. Now push the pusher to return the seconds wheel, minute register wheel, and hour register wheel to zero. With the flyback lever holding these wheels at a zero position, place the sweep second hand at 60 on the split second scale "D", the minute register hand at 60 on the minute register scale "E", and the hour register hand at 12 on the hour register scale "F". After the hands are replaced and checked for proper clearance, the chronograph should be engaged and let run for a period of time, then the hands returned to zero. This should be repeated several times as a check to make sure the chronograph hands consistently return to their respective zero positions.