

WORLD'S ONLY
FULLY ILLUSTRATED
CHRONOGRAPH WATCH COURSE
VOLUME 28

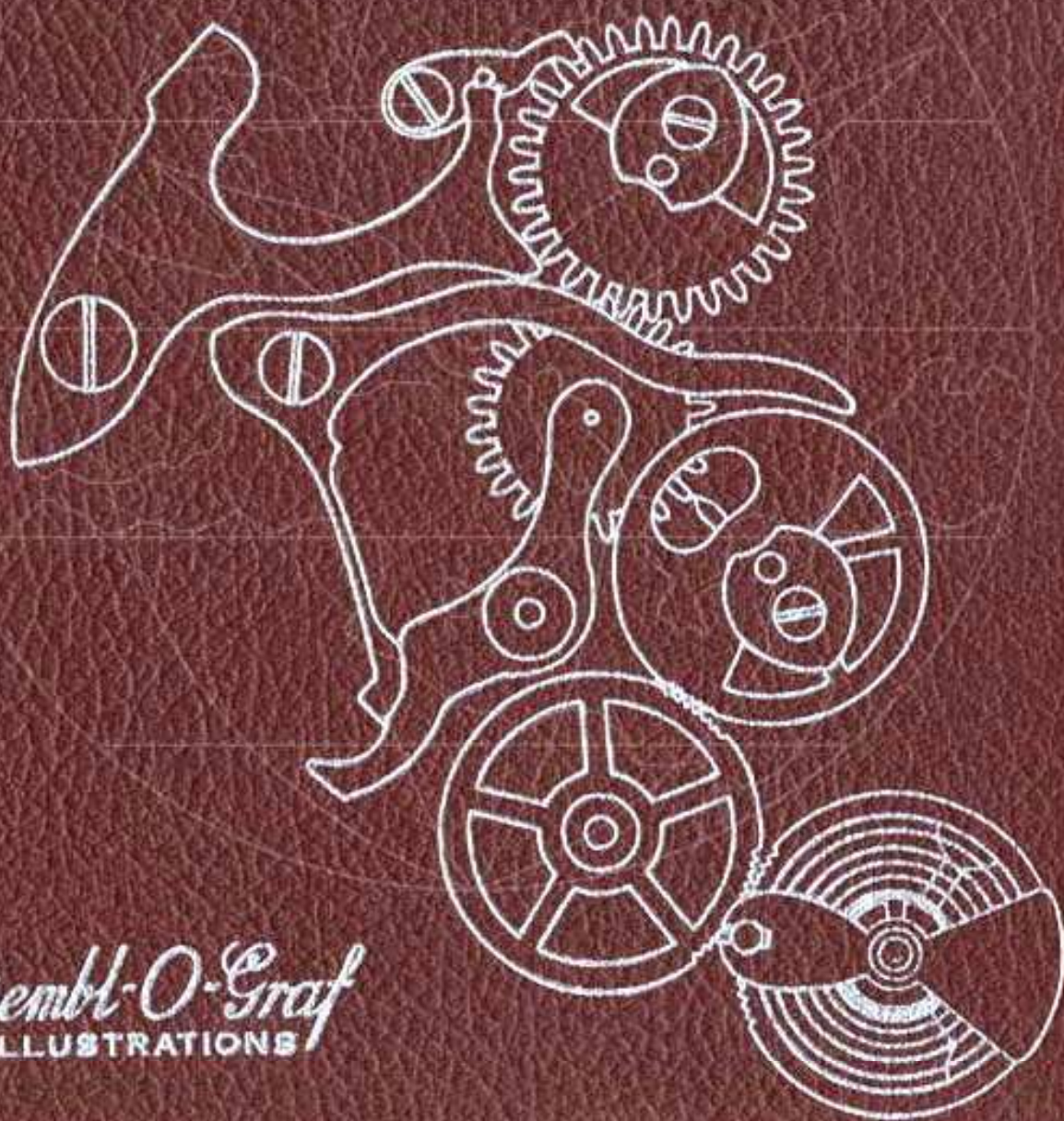

Esembl-O-Graf
ILLUSTRATIONS

IDENTIFICATION OF CHRONOGRAPH

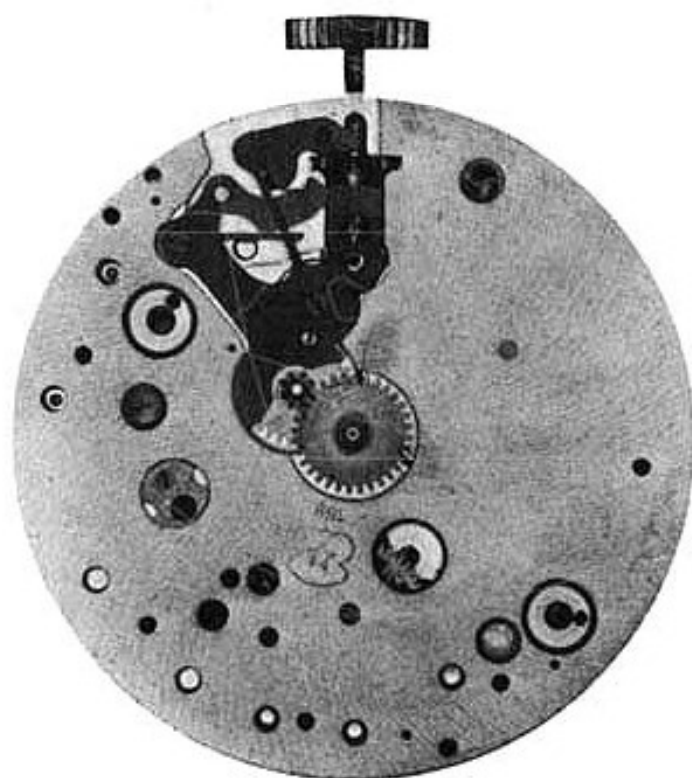

14L



VENUS
CAL. 188



ESEMBL-O-GRAF

THE WORLD'S FIRST FULLY
ILLUSTRATED TEXT BOOK
ON
CHRONOGRAPH REPAIRING
AND ADJUSTING

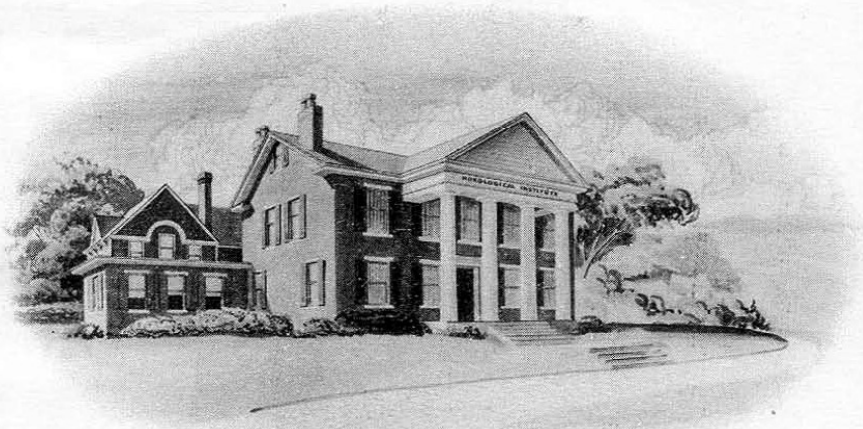

BY
William O. Smith, Sr.
PRESIDENT AND TECHNICAL DIRECTOR
AND
William O. Smith, Jr.
CHIEF ENGINEER, RESEARCH LABORATORIES

WESTERN PENNSYLVANIA HOROLOGICAL INSTITUTE, INC.
PITTSBURGH, PENNSYLVANIA

INSTRUCTIONS

For use of book

DISASSEMBLY OF THE CHRONOGRAPH MECHANISM:

1. Study the isometric drawing at top of page 1-A. The isometric drawing was made for the following purposes:

- A. It helps to identify the part to be removed.
- B. This drawing aids in pointing out certain locations on the part that are mentioned in the oiling procedure.
- C. The text refers to certain points on the part. These points are shown in the isometric drawing. This should aid you in finding the exact location on the part that is described in the text.
- D. It helps you to know the shape of the part in case a new part has to be made.

2. At the bottom of the page 1-A is a photograph of a chronograph. In this photograph is the same part painted in black. The part is in the exact location that it occupies in the watch. Find this location in the watch.

3. Read the disassembly procedure and the hazards in disassembly on page 1 in this book.

4. Remove this part in the same procedure as described in the text.

5. A very important item in disassembling a chronograph is keeping the screws in order. Much time will be lost in putting the chronograph together if screws are mixed up. This means you have to hunt for each screw, sometimes trying three or four screws before finding the correct one. It cannot be stressed too strongly that care should be taken so that screws are not mixed up. The system that we advise for beginners, is to replace each individual screw after each part is removed. This naturally eliminates the hazard of mixing up the screws and will save you much time in the end. Do this at least until you become so thoroughly familiar with the chronograph that you no longer feel it is necessary.

6. Continue to follow this procedure throughout the book and disassemble each part until the last part of the chronograph is removed.

ASSEMBLY OF THE CHRONOGRAPH MECHANISM:

7. When you are ready to assemble the chronograph mechanism, study the isometric drawing on the last part in this book. This drawing should aid you in identifying the part to be assembled.

8. At the bottom of that page is a photograph of a chronograph. In this photograph is the same part painted in black. The part is in the exact location that it occupies in the watch.

9. Read the assembly procedure and the hazards in assembling for the last part in this book. (Continued on next page)

INSTRUCTIONS (Continued)

10. Replace the part in its exact location as shown in photograph, using the procedure as described in the text.

11. After you find the correct location for the part in the watch, read the oiling procedure. The oiling procedure for each part is located underneath the isometric drawing. It is best to read the oiling procedure before you replace each part, as there are certain parts that must be oiled immediately as it may prove difficult to oil them later.

12. Replace the screw that holds the part in place. Of course, the screws should be kept in order as we advised above, but if the screws are not in order, or the watch was received with screws mixed up, you will find an enlarged drawing of the screw for each part that requires a screw, at the bottom of the text page.

13. After replacing this part, replace the next part, etc., until the last part is replaced, which will be part No. 1. Each part should be replaced using the same procedure as described in the text.

(Naturally, the assembly of the chronograph is exactly the reverse of the disassembly)

14. After disassembling and assembling the chronograph mechanism, start on page 1 and read the function of this part. After reading the function of this part, continue to read the function of each part throughout the book. Study each part, one at a time. This text should help you to understand more fully the purpose of each part in the chronograph mechanism.

15. Now put the movement in its case with the dial on, then replace the hands.

16. Study the text on functional results in this book, and check the chronograph mechanism as described in this text.

NOMENCLATURE OF PARTS FOR CHRONOGRAPH MECHANISM























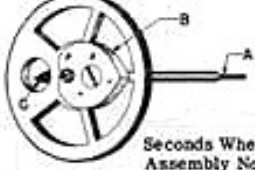

17. After you have become familiar with the chronograph mechanism, you can disassemble and assemble the chronograph by using the nomenclature of parts as a guide. This makes it possible for you to follow a procedure without going through each page in the book.

18. ADJUSTMENT OF ECCENTRIC STUDS:

Read the text on adjustment of eccentric studs. This should be read in reference to the eccentric stud picture. Now adjust each eccentric stud one at a time in the watch, as described in the text, using the illustration which shows you the position of these studs.

19. On each page in this book, the part number and the page number are the same. This makes it convenient for the reader and eliminates any confusion.

NOMENCLATURE OF PARTS FOR CHRONOGRAPH MECHANISM

 <p>Wheel Over Fourth Wheel Assembly No. 1</p>	 <p>Minute Register Pawl Assembly No. 2</p>	 <p>Flyback Lever Spring Assembly No. 3</p>
 <p>Flyback Lever Assembly No. 4</p>	 <p>Chronograph Pivoted Detent Bridge Assembly No. 5</p>	 <p>Intermediary Wheel Assembly No. 6</p>
 <p>Chronograph Pivoted Detent Spring Assembly No. 7</p>	 <p>Chronograph Pivoted Detent Assembly No. 8</p>	 <p>Push Piece for Setting Back to Zero Assembly No. 9</p>
 <p>Flyback Actuating Lever Spring Assembly No. 10</p>	 <p>Flyback Actuating Lever Assembly No. 11</p>	 <p>Flyback Actuating Push Piece Assembly No. 12</p>
 <p>Seconds Wheel and Minute Register Wheel Bridge Assembly No. 13</p>	 <p>Minute Register Wheel Assembly No. 14</p>	 <p>Seconds Wheel Assembly No. 15</p>
 <p>Seconds Wheel Tension Spring Assembly No. 16</p>	 <p>Intermittent Lever Spring Assembly No. 17</p>	 <p>Intermittent Lever and wheel Assembly Assembly No. 18</p>
 <p>Chronograph Assembly Plate Assembly No. 19</p>	 <p>Push Piece Spring Assembly No. 20</p>	 <p>Sweep Second Hand</p>
 <p>Minute Register hand</p>	 <p>Chronograph button</p>	 <p>Chronograph button</p>

ADJUSTING ECCENTRIC STUDS

Listed below are the adjustments controlled by eccentric studs. We call them studs because they are not held in the plate like screws. The post on the lower side that is in the plate, has a smooth surface, and is held only by friction. The head of the stud is eccentric to the post so that when the stud is turned, the head will turn eccentrically. These eccentric studs should have a tight fit in their holes to prevent them from changing their position after they have been adjusted. Of course, on the other hand, the eccentric studs should not be so tight that they cannot be turned with a screwdriver.

THINGS TO CHECK

ES-1- Check the depthing of the wheel over fourth wheel with the intermediary wheel. (The proper depthing of these wheels are illustrated in Volume 24, Part 10, Page 95.) If the depthing is incorrect, it can be corrected by adjusting eccentric stud ES-1.

ES-2- Check depthing of intermediary wheel teeth with seconds wheel teeth. (The proper depthing of these wheels is illustrated in Volume 24, Part 10, Page 95.) If depthing is incorrect it can be corrected by adjusting eccentric stud ES-2.

ES-3- Check to see that when the flyback lever is moved to the position to disengage the chronograph, that the intermediary wheel disengages sufficiently from the seconds wheel. If the intermediary wheel does not disengage sufficiently from the seconds wheel, this condition can be corrected by adjusting eccentric stud ES-3.

ES-4- Check depthing of intermittent wheel teeth with seconds wheel dart tooth. If this depthing is incorrect, it may be corrected by adjusting eccentric stud ES-4.

REFERENCE: Wheel over fourth wheel is Assembly 1.
Intermediary wheel is Assembly 6.
Seconds wheel is Assembly 15.
Intermittent wheel is Assembly 18.

ADJUSTING ECCENTRIC STUDS

DO NOT REMOVE THESE STUDS

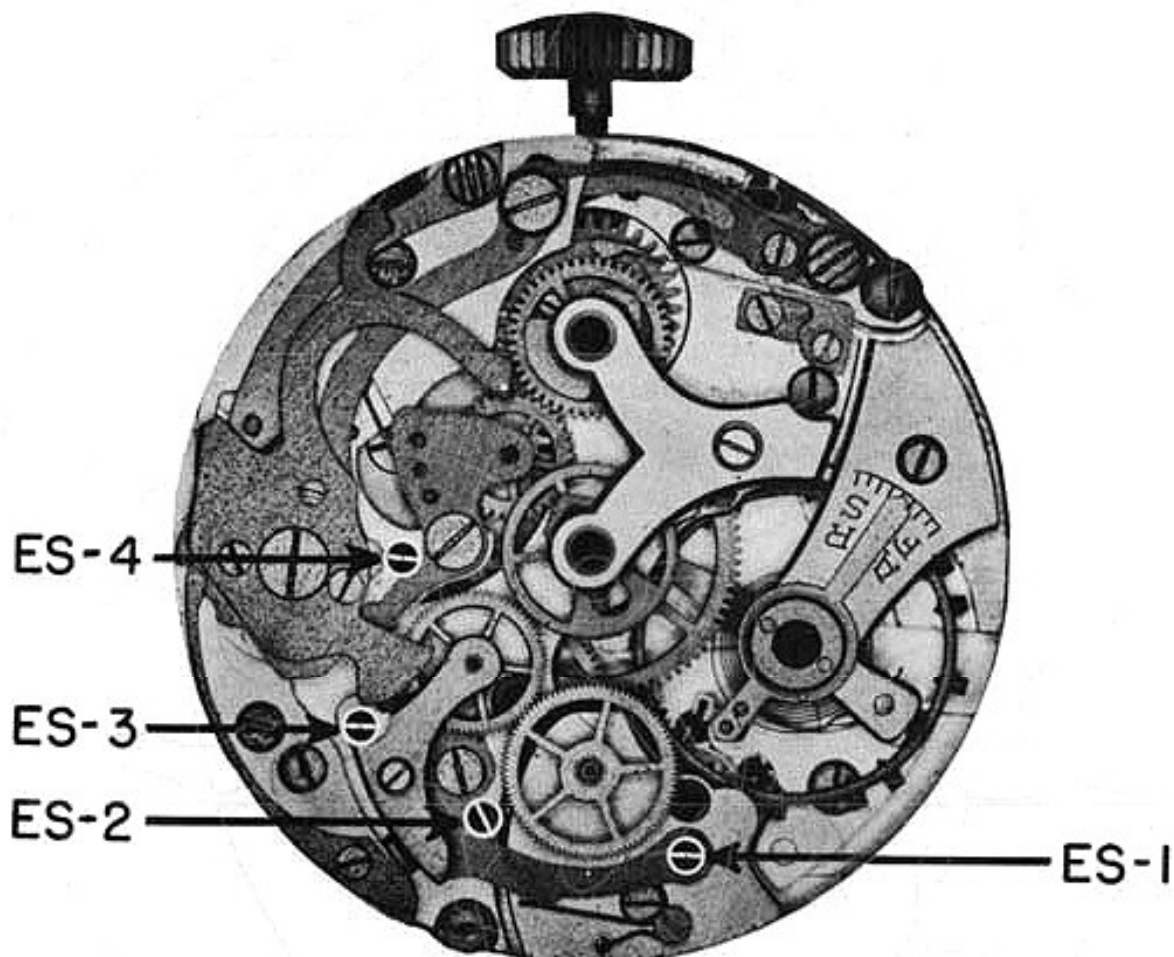

CAUTION

In disassembling or assembling chronograph, it is a good policy not to turn eccentric studs. These eccentric studs are used to adjust one part to another, and naturally, in turning these studs you will lose the desired adjustment of the chronograph mechanism, which will cause the chronograph to function incorrectly. Another reason for not turning these studs, unless it is necessary, is that they soon become loose and will not hold the desired adjustment.

PART NO. 1

A. DISASSEMBLY PROCEDURE OF WHEEL OVER FOURTH WHEEL:

The wheel over fourth wheel fits friction tight on long pivot of the fourth wheel pinion. This wheel should be removed with a sweep wheel remover, but can be removed with two small thin-edged screwdrivers. The screwdrivers are placed opposite each other under hub "A" of wheel. One screwdriver is turned clockwise, while the other screwdriver is turned counter-clockwise. This will loosen the wheel from the pivot, permitting it to be lifted out of place.

(For more detailed instructions with illustration on the procedure for removing the wheel over fourth wheel, see Volume 24, Part 10, Page 91.

B. HAZARDS IN DISASSEMBLY OF WHEEL OVER FOURTH WHEEL:

The wheel over fourth wheel fits over the very thin, long pivot of the fourth wheel pinion. This pivot, as you know, is very delicate, and easily bent or broken. The main reason why we selected this part to be one of the first parts to be removed from the chronograph mechanism, was to lessen the hazards of bending the long pivot on the fourth wheel pinion when removing the other parts of the chronograph mechanism. If the sweep wheel remover is held perfectly upright in removing wheel, the hazard of bending the fourth wheel pivot will be eliminated.

C. ASSEMBLY PROCEDURE OF WHEEL OVER FOURTH WHEEL:

This wheel fits over the long pivot of the fourth wheel, and should be placed on the pivot with hub "A" of wheel down. The wheel over fourth wheel should be staked down until it is level with the intermediary wheel. A hollow flat-faced punch should be used to stake the wheel down.

D. HAZARDS IN ASSEMBLY OF WHEEL OVER FOURTH WHEEL:

Use care in staking down this wheel, so that you do not bend or break the fourth wheel pivot. If movement is held level, the hazards in replacing this wheel will be eliminated.

E. FUNCTION OF WHEEL OVER FOURTH WHEEL:

The function of this wheel is to transmit the power from the train of the watch to the chronograph mechanism. This wheel continues to turn as long as the watch is running.

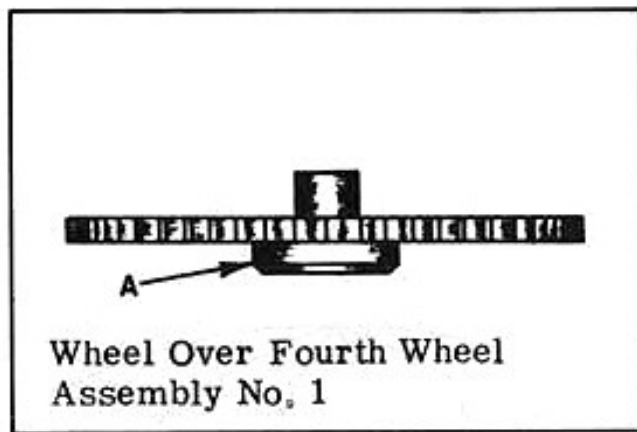

OILING

The wheel over fourth wheel should not be oiled.

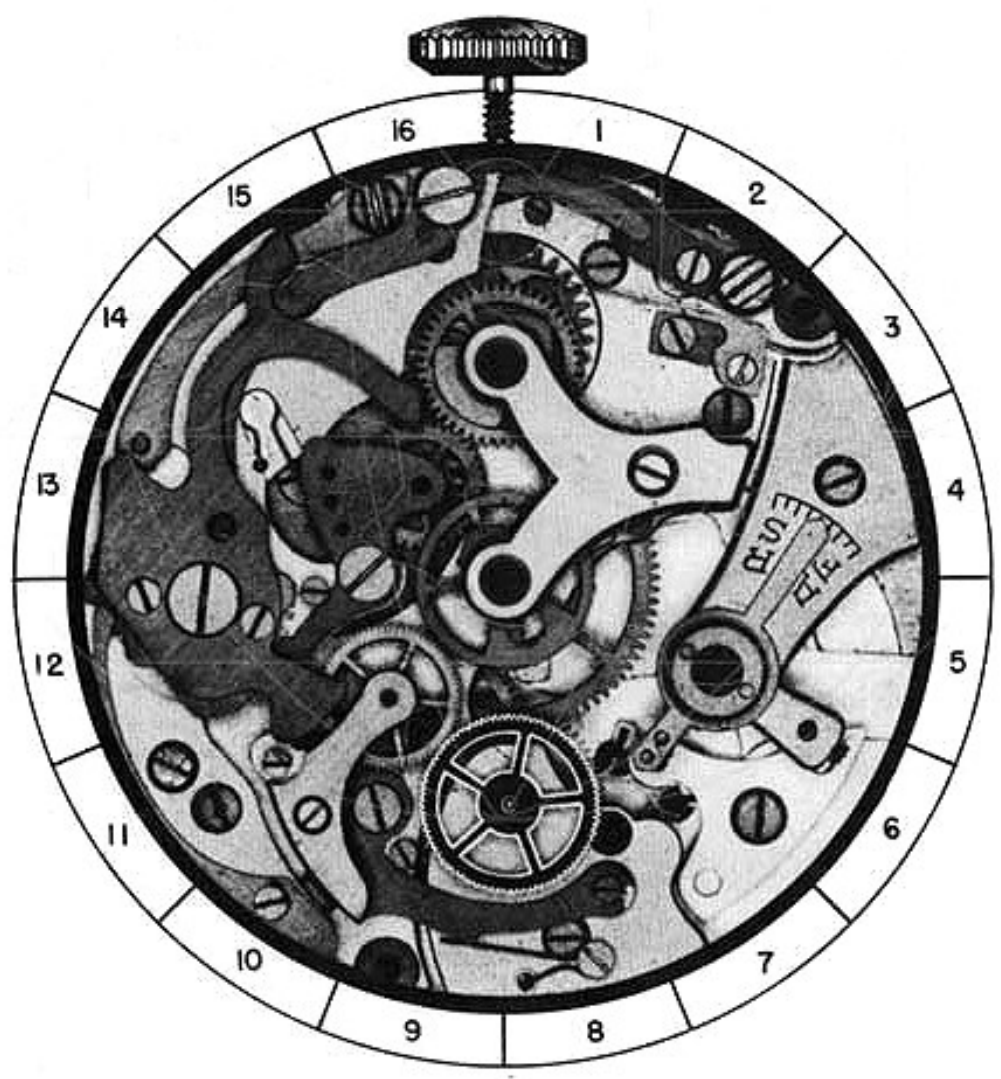

1-A

PART NO. 2

Notice: To avoid readjusting the minute register pawl each time it is disassembled, remove the minute register pawl from the minute register pawl plate. Due to the plate remaining on the movement, the pawl can be replaced in the exact position from which it was removed.

A. DISASSEMBLY PROCEDURE OF MINUTE REGISTER PAWL:

The minute register pawl is held to an adjustable pawl plate by fillister head screw FS-1, and a steady pin. The adjustable pawl plate is held to the watch plate by beveled countersink screw BS-1. The position of these screws is shown in the photograph. To remove the pawl from the adjustable plate, remove fillister head screw FS-1, and loosen the pawl from the adjustable plate by sliding a finely sharpened screwdriver under the base of the pawl. When the steady pin is free in the adjustable plate, the pawl may be lifted from the movement.

(The shape of screws for this part is shown at bottom of page.)

B. HAZARDS IN DISASSEMBLY OF MINUTE REGISTER PAWL:

The blade of the pawl is very thin, and easily damaged. Use care in disassembly.

C. ASSEMBLY PROCEDURE OF MINUTE REGISTER PAWL:

Place the steady pin and the hole in the pawl directly over their respective holes in the minute register pawl plate. Press the pawl down on the plate, making sure that the end "A" of the pawl is not on top of the minute register wheel, but centered between two teeth on this wheel. When the pawl is in the proper position on the pawl plate, replace fillister head screw FS-1 to hold the pawl in position.

D. ADJUSTING THE MINUTE REGISTER PAWL:

To adjust the minute register pawl, push the push piece for setting back to zero to return the seconds wheel and minute register wheel to a zero position. With the flyback lever holding these wheels at a zero position, loosen the beveled countersink screw BS-1, and move the adjustable plate until the end "A" of the pawl is centered between two teeth of the minute register wheel. Now tighten screw BS-1 to hold the plate and pawl in position. The tension of the minute register pawl on the minute register wheel must be very light, as too much tension causes the minute register wheel to be unnecessarily hard to turn, and may cause the watch to stop. Still, there must be enough tension on the pawl for it to function properly, as described below.

E. FUNCTIONS OF THE MINUTE REGISTER PAWL:

The functions of the minute register pawl are as follows:

1. It correctly spaces the turning of the minute register wheel so that the wheel moves exactly one tooth each minute.
2. It holds the minute register wheel in a stationary position so that a bump cannot alter the position of this wheel.

(For more detailed instructions, with illustrations, on setting the tension of the minute register pawl, see Volume 24, Part 6, Page 71.)

REFERENCE: Minute register wheel is Assembly 14.
Push piece for setting back to zero is Assembly 9.
Flyback lever is Assembly 4.

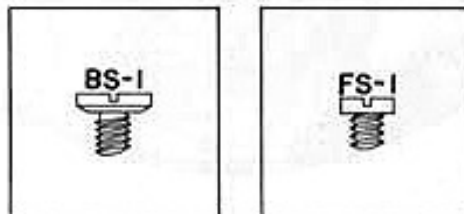

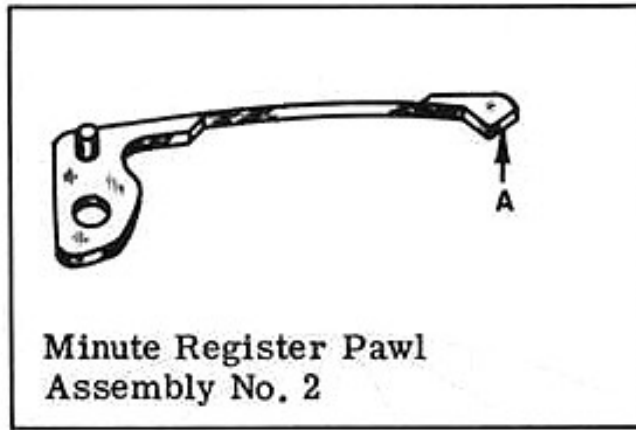

OILING

The minute register pawl should not be oiled.

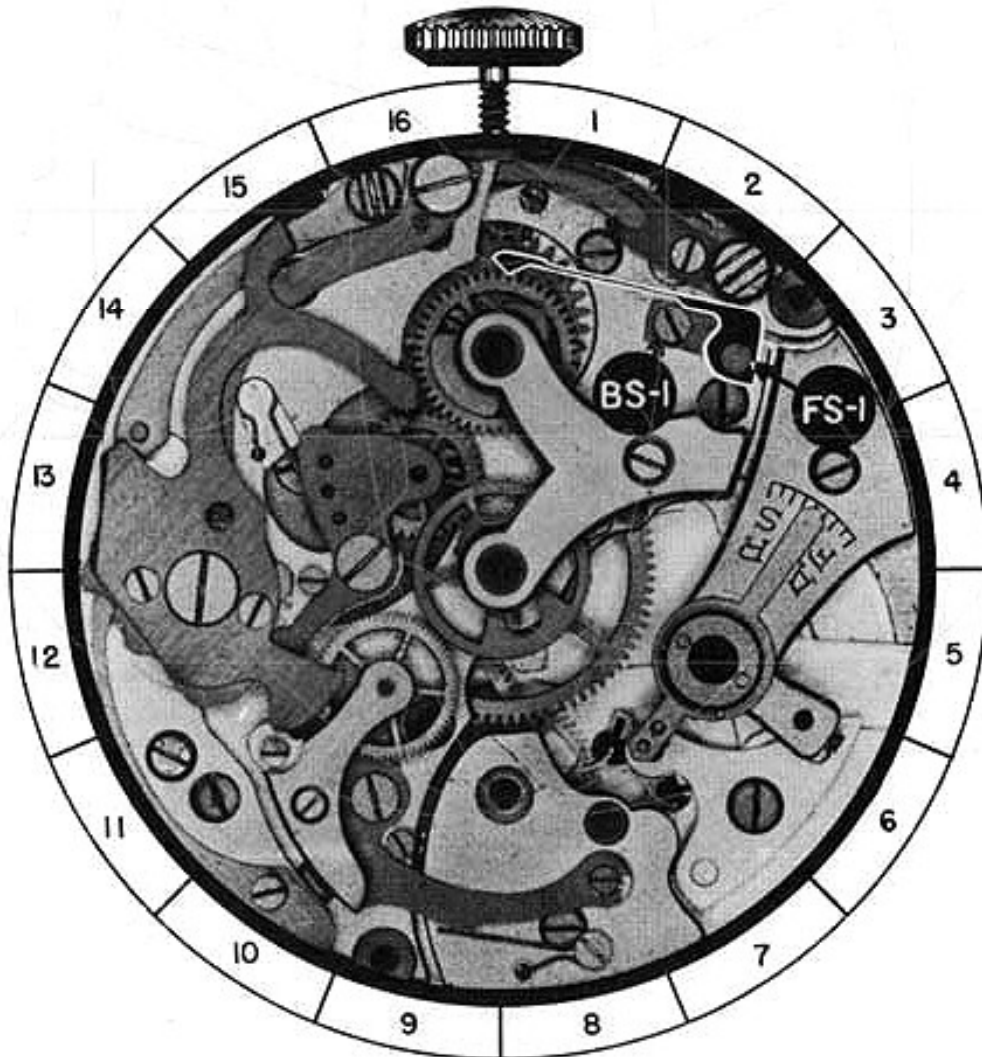

2-A

PART NO. 3

A. DISASSEMBLY PROCEDURE OF FLYBACK LEVER SPRING:

This spring is held in place by fillister head screw FS-2 and a steady pin. When screw is removed, slide a finely-sharpened screwdriver under the spring to loosen it from the plate. When steady pin is free of plate, spring may be removed with tweezers.

(The shape of screw for this part is shown at the bottom of the page.)

B. ASSEMBLY PROCEDURE OF FLYBACK LEVER SPRING:

To replace this spring, move the flyback lever as far as possible toward the center of the watch. Then place the spring in position with the steady pin in the proper hole in the plate. The end "A" of the spring should set against the edge of the flyback lever. Now push the base of the spring to bring the hole directly over the screw hole in the plate and replace fillister head screw FS-2, which holds this spring in place.

C. HAZARDS IN ASSEMBLY OF FLYBACK LEVER SPRING:

When pressing spring to exact position, be sure end "A" of spring is not on top of the flyback lever or spring may be bent or burred.

D. REMARKS:

The end "A" of spring which contacts the flyback lever should be carefully examined for burrs. If any burrs are found, they should be removed. This end of spring should be highly polished to work properly.

E. FUNCTION OF FLYBACK LEVER SPRING:

The functions of this spring are:

1. It holds the flyback lever at rest away from the center of the watch. With the flyback lever in this position, the registration of the chronograph is taking place.
2. It holds the flyback lever at rest, after the flyback lever has been moved toward the center of the watch just far enough to disengage the intermediary wheel from the seconds wheel. With the flyback lever in this position, the registration of the chronograph is stopped.
3. It holds the flyback lever arms "C" and "D" against the hearts on the seconds wheel and minute register wheel, after these wheels have been returned to zero position.

REFERENCE: Intermediary wheel is Assembly 6.
Seconds wheel is Assembly 15.
Minute register wheel is Assembly 14.

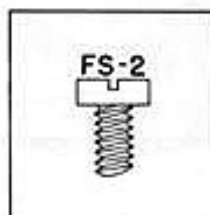

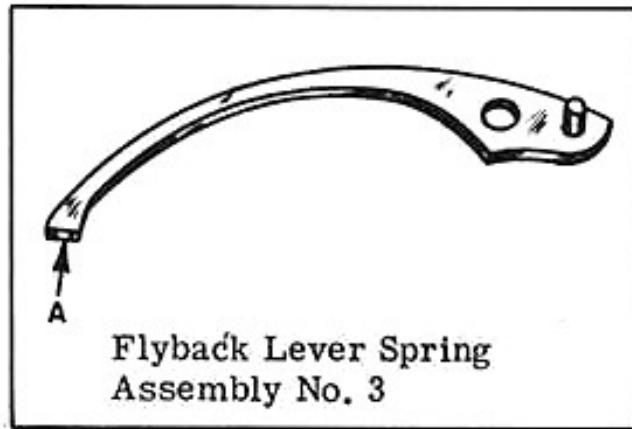

OILING

The end "A" of flyback lever spring at point of contact with flyback lever should be slightly moistened with oil.

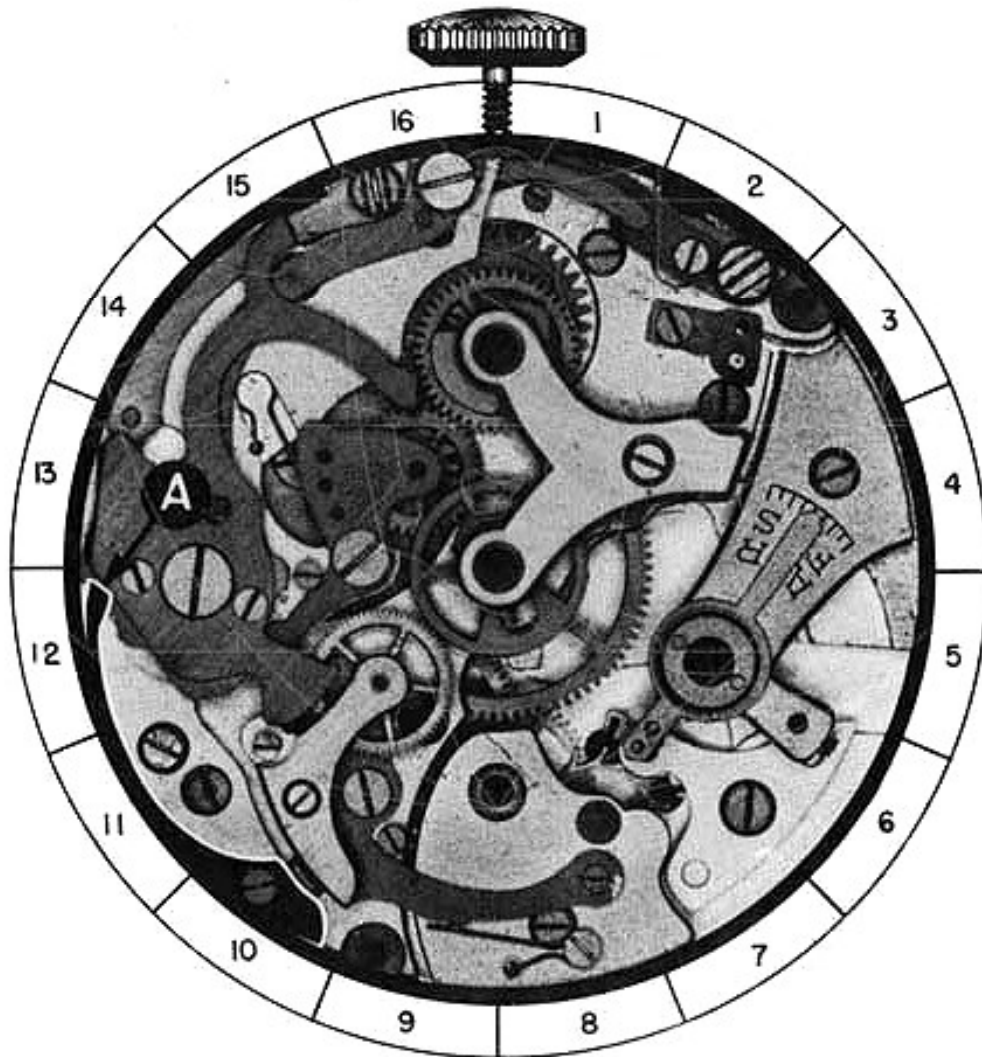

3-A

PART NO. 4

A. DISASSEMBLY PROCEDURE OF FLYBACK LEVER:

The flyback lever pivots on a stud on the plate, and is held in place by the fillister head screw FS-3. When this screw is removed, the flyback lever may be lifted from the stud and free from movement.

(The shape of screw for this part is shown at bottom of page.)

B. ASSEMBLY PROCEDURE OF FLYBACK LEVER:

Place the flyback lever in position with hole in lever over the stud on the plate as shown in the photograph. Make sure that the surface "A" of lever is not on top of eccentric stud ES-3. Also make sure the surface "B" is not hitting on top of pin "E" on push piece. When the flyback lever is seated properly on the plate, fillister head screw FS-3 must be replaced.

C. FUNCTION OF FLYBACK LEVER:

The functions of the flyback lever are:

1. It disengages the intermediary wheel from the seconds wheel.
2. It disengages the intermittent wheel from the seconds wheel dart tooth.
3. The ends of flyback lever "D" and "C" hit the hearts on the seconds wheel and minute register wheel, forcing these wheels and the hands attached to them back to a zero position.

Due to the construction of this book, it is impossible to print at this place how the function of the flyback lever is performed in a non-castle wheel type chronograph. This explanation will be found in Volume 24, Part 4, Pages 31 to 36.

REMARKS:

In order to see the function of the flyback actuating lever in relation to the flyback lever, the peephole "F" is provided. (For further information in regards to this function see page 11.)

REFERENCE: Intermediary wheel is Assembly 6.
Seconds wheel is Assembly 15.
Intermittent wheel is Assembly 18.
Minute register wheel is Assembly 14.
Push Piece for setting back to zero is Assembly 9.

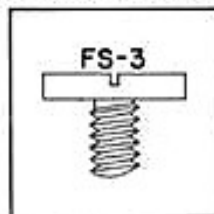

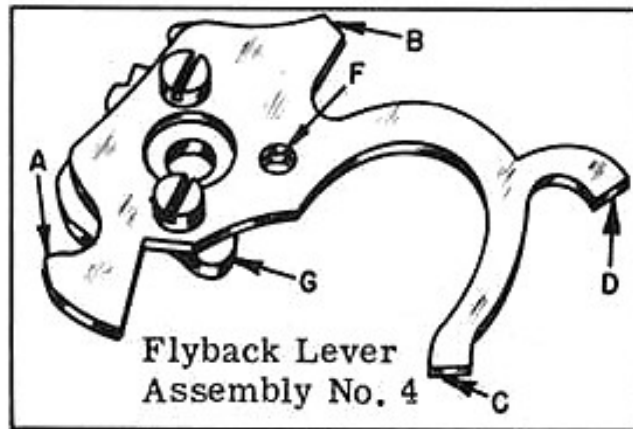

OILING

- The following parts of flyback lever should be slightly moistened with oil:
1. The surface of the flyback lever that contacts end "A" of the flyback actuating lever. This oiling can be done through the peep hole "F".
 2. At point of contact with pin "E" on push piece for setting back to zero.
 3. At point of contact with stud ES-3 on chronograph pivoted detent.
 4. Surface "G" that comes in contact with intermittent lever.
 5. The hollow stud on which the flyback lever pivots.

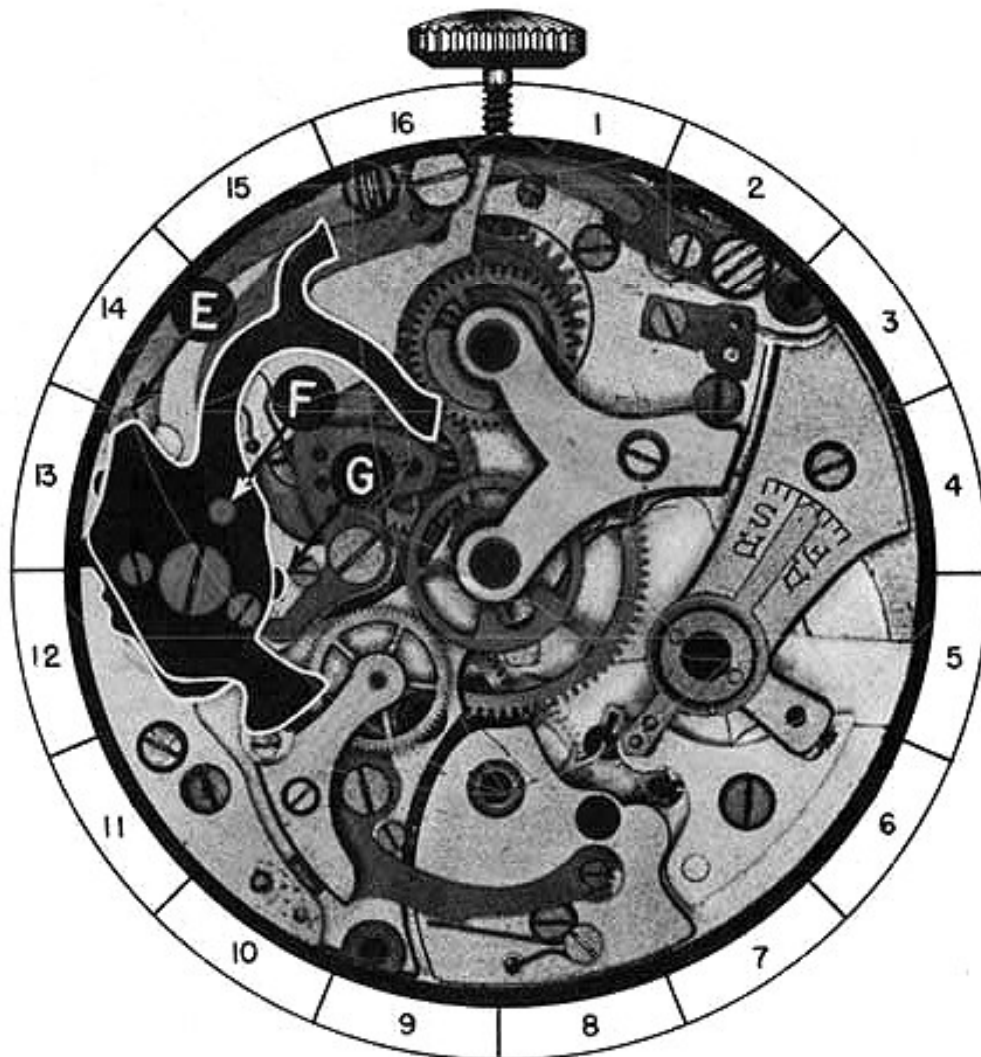

4-A

PART NO. 5

A. DISASSEMBLY PROCEDURE OF CHRONOGRAPH PIVOTED DETENT BRIDGE:

This bridge is held in place by fillister head screw FS-4 and steady pins. Remove screw and loosen bridge from chronograph pivoted detent, by sliding a thin blade screwdriver under bridge. When steady pins are free in detent, bridge may be lifted out of place.

(The shape of screw for this part is shown at the bottom of page.)

B. HAZARDS IN DISASSEMBLY OF CHRONOGRAPH PIVOTED DETENT BRIDGE:

When using a screwdriver to loosen bridge from detent, care should be taken to keep bridge level, as any twisting may damage pivot on intermediary wheel or burr the bushing in bridge or pivoted detent. The screwdriver should be carefully used to prevent marring of bridge or detent.

C. ASSEMBLY PROCEDURE OF CHRONOGRAPH PIVOTED DETENT BRIDGE:

Place bridge on chronograph pivoted detent with steady pins over proper holes in detent. Place intermediary wheel so that pivot on this wheel will enter bushing in bridge. Bridge may now be pressed down to proper place with back of tweezers, and fillister head screw FS-4 replaced in bridge.

D. HAZARDS IN ASSEMBLY OF CHRONOGRAPH PIVOTED DETENT BRIDGE:

Keep bridge level when pressing down to proper place, as any twisting may burr the bushing in the bridge or damage the pivot on intermediary wheel. The bridge and detent, where these two parts come together, should be checked to see that there are no burrs which would prevent the bridge from setting properly on chronograph pivoted detent. At this point it is advisable to check the intermediary wheel to see that it has proper endshake. Also, check to see that it spins freely.

E. FUNCTION OF CHRONOGRAPH PIVOTED DETENT BRIDGE:

The function of this bridge is to provide a bearing surface for the top pivot of the intermediary wheel:

REFERENCE: Chronograph pivoted detent is Assembly 8.
Intermediary wheel is Assembly 6.

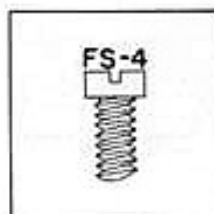

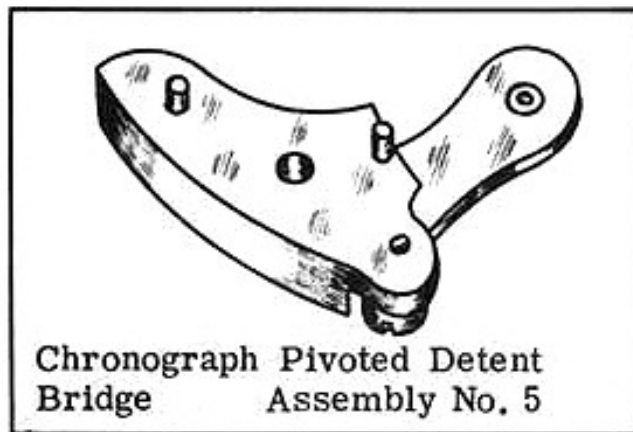

Chronograph Pivoted Detent
Bridge Assembly No. 5

OILING

The pivot hole in this bridge should be oiled as you would oil a train pivot in a watch.

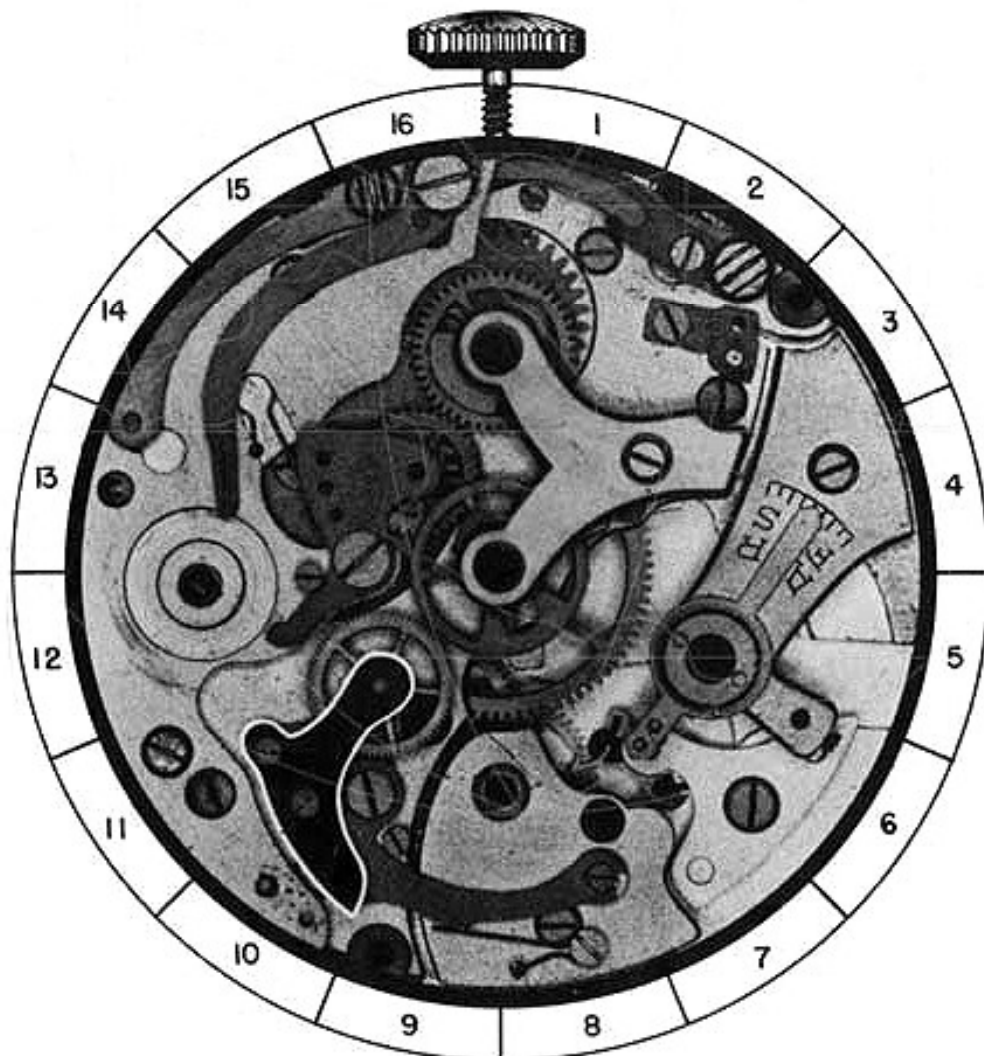

5-A

PART NO. 6

A. DISASSEMBLY PROCEDURE OF THE INTERMEDIARY WHEEL:

To remove the intermediary wheel, simply lift it out of place.

B. ASSEMBLY PROCEDURE OF THE INTERMEDIARY WHEEL:

When replacing the intermediary wheel, the end "A" of staff should be up. Place the bottom pivot "B" of staff in hole in bushing of chronograph pivoted detent.

C. HAZARDS IN ASSEMBLY OF THE INTERMEDIARY WHEEL:

The pivot hole in bushing of chronograph pivoted detent should be carefully examined before replacing the intermediary wheel. Any imperfections here will affect the timekeeping of the watch and hinder proper operation of the chronograph.

D. FUNCTION OF THE INTERMEDIARY WHEEL:

Function of the intermediary wheel is to transmit the power from the wheel over fourth wheel to the seconds wheel when these wheels are engaged. The intermediary wheel continues to turn as long as the watch is running.

REMARKS:

A careful and detailed examination should be made of all wheels before replacing them in the chronograph. Each wheel should be examined for burred pivots, bent or burred teeth, dirt or small pieces of grit wedged between the teeth. When the VEE shaped teeth of one wheel mesh into the VEE shaped teeth of another wheel, there is very little clearance between the teeth, and because of this, the smallest piece of grit or dirt wedged between two teeth may stop the chronograph. The intermediary wheel has VEE shaped teeth.

REFERENCE: Chronograph pivoted detent is Assembly 8.
Seconds wheel is Assembly 15.
Wheel over fourth wheel is Assembly 1.

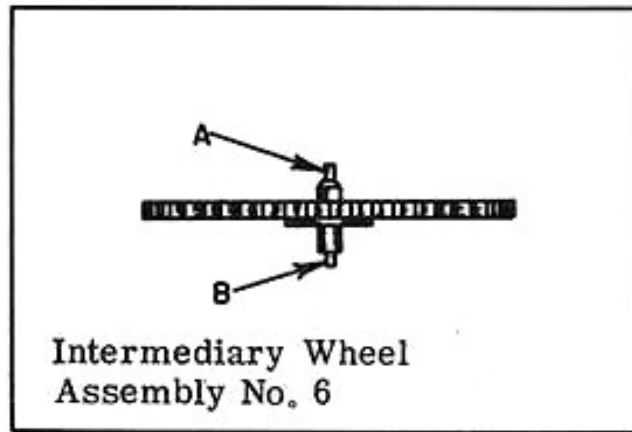

OILING

The bottom pivot of intermediary wheel should be oiled before placing it in the chronograph pivoted detent. The top pivot should be oiled after the bridge for this wheel is replaced.

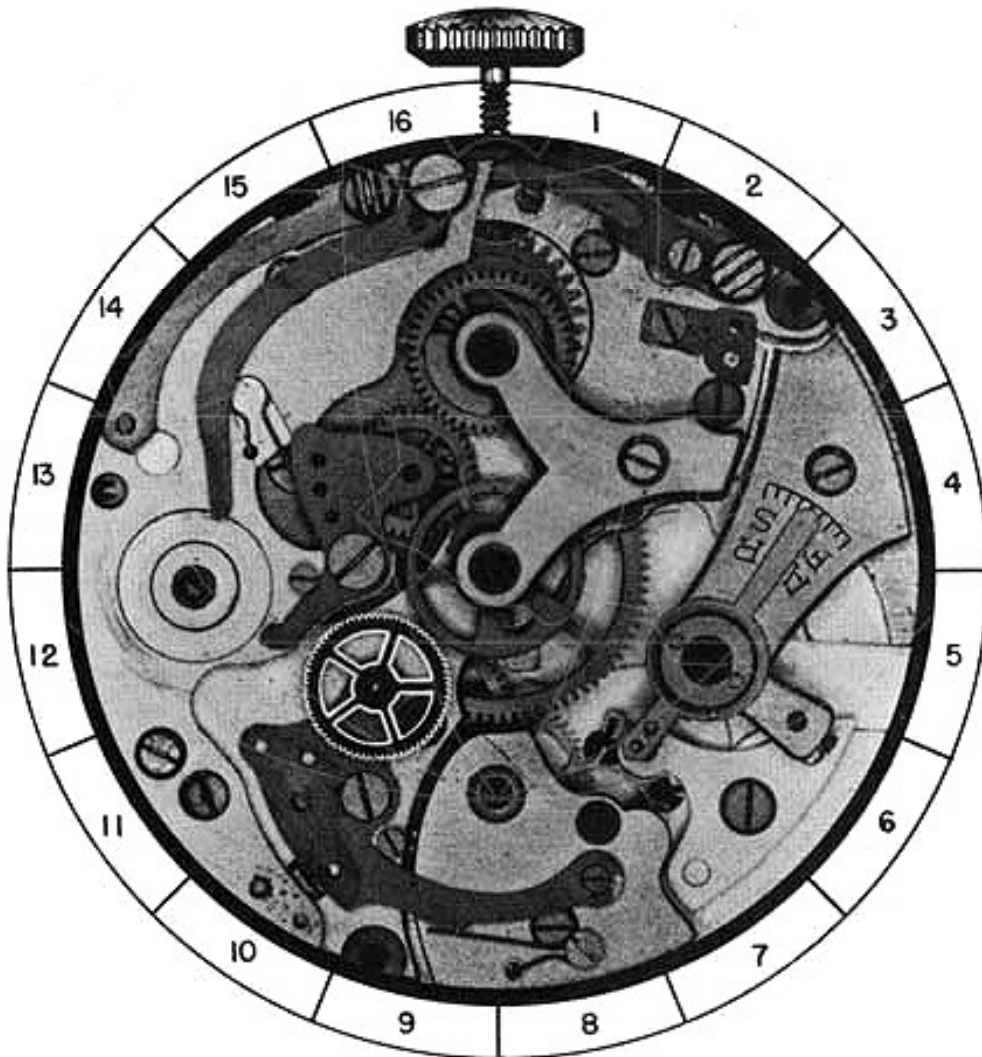

6-A

PART NO. 7

A. DISASSEMBLY PROCEDURE OF CHRONOGRAPH PIVOTED DETENT SPRING:

This spring is held in place by fillister head screw FS-5. After this screw is removed, the spring may be lifted from the plate.

(The shape of screw for this part is shown at the bottom of the page.)

B. HAZARDS IN DISASSEMBLY OF CHRONOGRAPH PIVOTED DETENT SPRING:

Hold finger over spring, when removing the screw, so that the spring does not shoot away and become lost.

C. ASSEMBLY PROCEDURE OF CHRONOGRAPH PIVOTED DETENT SPRING:

Place the spring in position with end "A" down in the proper hole and the loop over the proper screw hole in plate. End "B" of the spring should be placed on top of the chronograph pivoted detent until fillister head screw FS-5 is replaced. However, before tightening down screw, the end "B" of the spring should be placed against the outer edge of the chronograph pivoted detent.

D. HAZARDS IN ASSEMBLY OF CHRONOGRAPH PIVOTED DETENT SPRING:

Hold finger over spring when tightening screw so that it cannot shoot away.

E. FUNCTION OF CHRONOGRAPH PIVOTED DETENT SPRING:

The function of this spring is to hold a tension on the chronograph pivoted detent, which forces the detent to engage the intermediary wheel with the seconds wheel.

REMARKS:

The tension of the chronograph pivoted detent spring should be strong enough to force the chronograph pivoted detent to engage the intermediary wheel with the seconds wheel. The spring should hold the seconds wheel and intermediary wheel engaged until the chronograph pivoted detent is forced to disengage them by the movement of the flyback lever.

REFERENCES: Flyback lever is Assembly 4
Chronograph pivoted detent is Assembly 8
Intermediary wheel is Assembly 6
Seconds wheel is Assembly 15

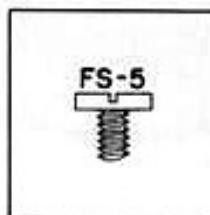

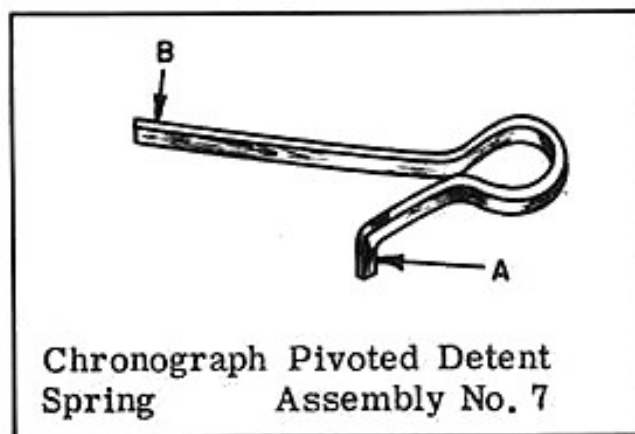

OILING

The end "B" of the chronograph pivoted detent spring should be slightly moistened with oil at point of contact with chronograph pivoted detent.



PART NO. 8

A. DISASSEMBLY PROCEDURE OF CHRONOGRAPH PIVOTED DETENT:

This detent pivots on an eccentric stud ES-1, and is held in place by shouldered screw SS-1. The position of the screw and stud is shown on the photograph. Remove shouldered screw SS-1 and left detent straight up from the eccentric stud. The detent may now be lifted from the movement.

(The shape of screw for this part is shown at the bottom of the page.)

B. ASSEMBLY PROCEDURE OF CHRONOGRAPH PIVOTED DETENT:

Place the detent in the proper position on the plate, with the hole in detent over the eccentric stud ES-1, as the detent pivots on this stud. Now replace shouldered screw SS-1 and check to see that the detent moves freely under the head of the shouldered screw.

C. HAZARDS IN ASSEMBLY OF CHRONOGRAPH PIVOTED DETENT:

After replacing shouldered screw SS-1, the chronograph pivoted detent should be checked to see that it has enough freedom to work properly, and still not have excessive freedom.

D. FUNCTION OF CHRONOGRAPH PIVOTED DETENT:

The function of the chronograph pivoted detent is to engage and disengage the intermediary wheel with the seconds wheel.

REMARKS:

When disassembling the chronograph, each part should be carefully examined as it is removed from the movement. Each part should be checked against the isometric drawing to see that the part is the correct shape, and is not broken. Each part should also be checked for any pits of rust, roughness or burrs, and for worn parts which may cause the part not to work properly. The replacement of a defective part in the chronograph may necessitate the complete disassembly of the chronograph. Through a close examination of each part, you will soon become familiar with the parts of the chronograph. This will enable you to quickly recognize a defective part, and repair it before replacing in the chronograph.

REFERENCE: Intermediary wheel is Assembly 6
Seconds wheel is Assembly 15

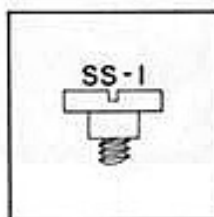

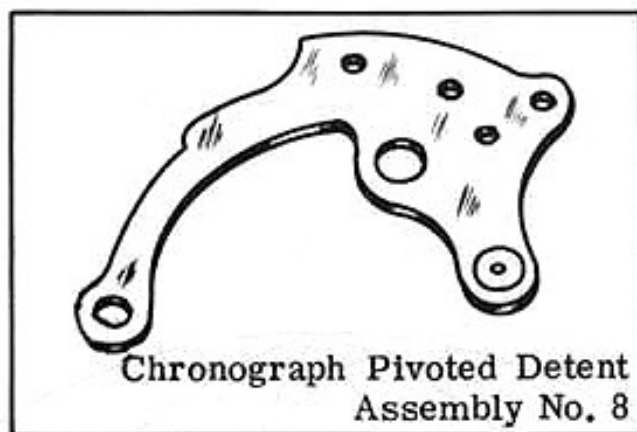

OILING

The eccentric stud ES-1 on which the chronograph pivoted detent pivots should be slightly moistened with oil.

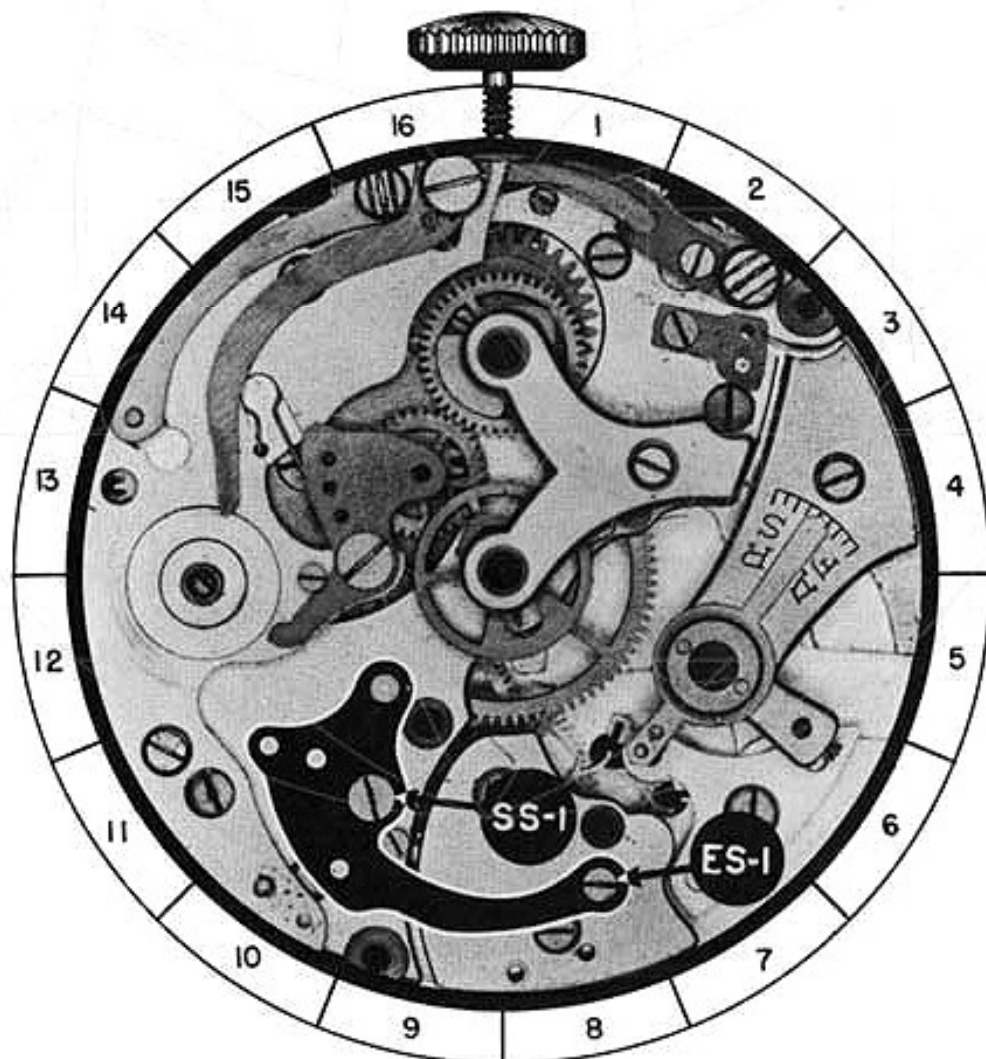

8-A

PART NO. 9

A. DISASSEMBLY PROCEDURE OF PUSH PIECE FOR SETTING BACK TO ZERO:

This push piece is held in place by a left threaded shouldered screw SS-2. After the screw is removed, the push piece may be lifted from the plate.

(The shape of the screw for this part is shown at the bottom of the page.)

B. ASSEMBLY PROCEDURE OF PUSH PIECE FOR SETTING BACK TO ZERO:

Place the push piece for setting back to zero in position on the plate, with the hole in the push piece over the proper screw hole. Now replace the left threaded shouldered screw SS-2. Check to see that the push piece moves freely under the head of this screw. The left threaded shouldered screw can be identified by two grooves running parallel to the screw slot.

C. FUNCTION OF PUSH PIECE FOR SETTING BACK TO ZERO:

The function of this push piece is when pushed, to force the flyback lever toward the center of the watch. The flyback lever then contacts the hearts and returns them to zero.

REMARKS:

This push piece can only actuate the flyback lever when the chronograph mechanism is disengaged. When the chronograph mechanism is disengaged, and this push piece is pushed, the pin "E" will contact the flyback lever, forcing it to return the hearts to zero. On the other hand when the chronograph is engaged, if this push piece is pushed, the lower end of pin "E" will contact the wall of the recess in the plate, thus preventing this lever from performing any function.

REFERENCE: Flyback lever is Assembly 4.
Seconds wheel is Assembly 15.
Minute register wheel is Assembly 14.

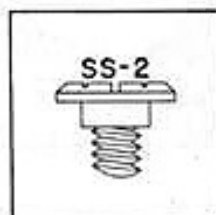

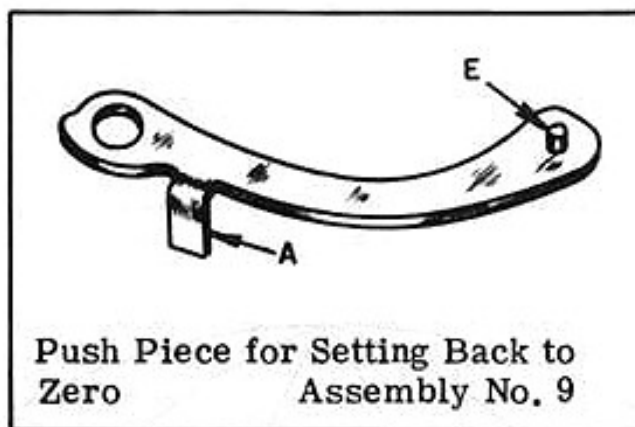

Push Piece for Setting Back to Zero
Assembly No. 9

OILING

The following locations on the push piece for setting back to zero should be moistened with oil.

1. Location "A" at point of contact with the push piece spring.
2. The shouldered screw SS-2 on which the push piece for setting back to zero pivots.

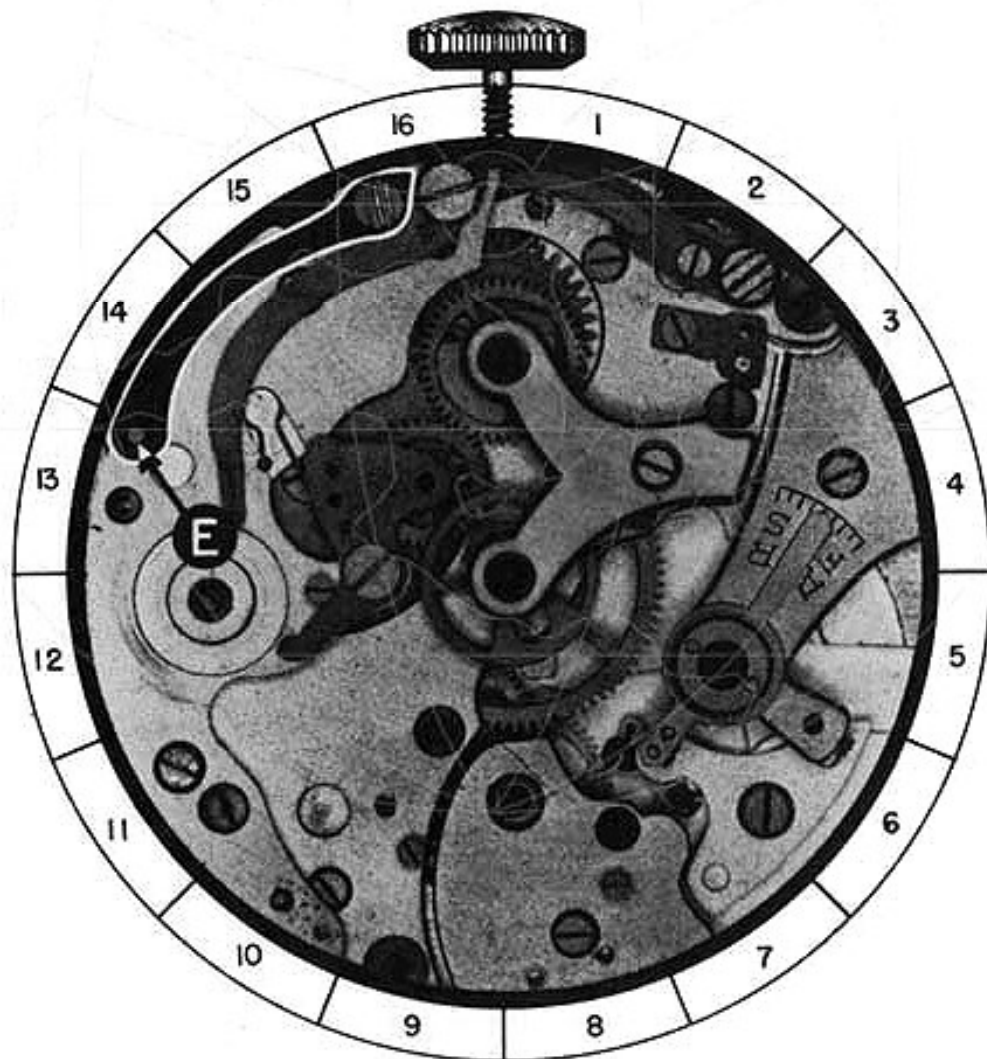

9-A

PART NO. 10

A. DISASSEMBLY PROCEDURE OF FLYBACK ACTUATING LEVER SPRING:

This spring is held in place by fillister head screw FS-6. When this screw is removed the spring can be lifted out of place.

B. ASSEMBLY PROCEDURE OF FLYBACK ACTUATING LEVER SPRING:

Place this spring in its proper position on the flyback actuating push piece. The end "B" of this spring which is bent down, should rest on the edge of the push piece, and the end "A" of spring should rest on top of the flyback actuating lever. Fillister head screw FS-6 can now be replaced, but before screw is tightened, end "A" of spring should be placed against the outer edge of the flyback actuating lever.

C. FUNCTION OF FLYBACK ACTUATING LEVER SPRING:

The function of this spring is to hold the flyback actuating lever in a negative position, until it is actuated by pushing the button. For further information on the function of the flyback actuating lever and spring, see page 11.

REMARKS:

This type of chronograph is a semi-instantaneous. It is possible to note immediately if a chronograph is a semi-instantaneous type, by observing the progress of the minute register hand. The minute register hand on a semi-instantaneous type chronograph will remain stationary until about the 58th second of registration. Between the 58th and the 60th second of registration, the hand will move forward very slowly. At the 60th second of registration, the minute register hand will move forward very quickly to complete the registration of one minute on the dial. Of course, the minute register hand progresses in the same manner for each consecutive minute of registration.

REFERENCE: FLYback actuating lever is Assembly 11
FLYback actuating push piece is Assembly 12.

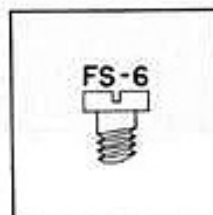

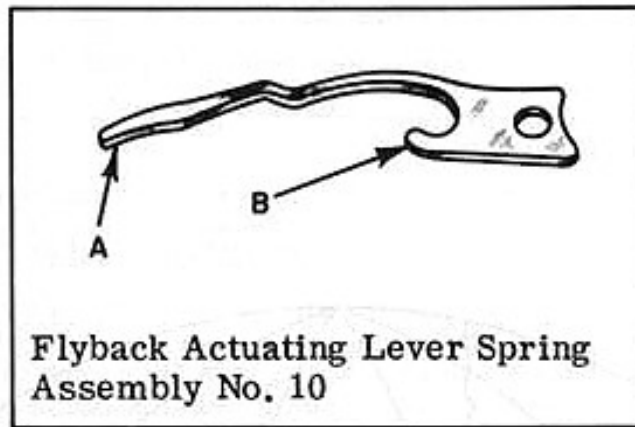

OILING

The end "A" of the flyback actuating lever spring should be slightly moistened with oil.

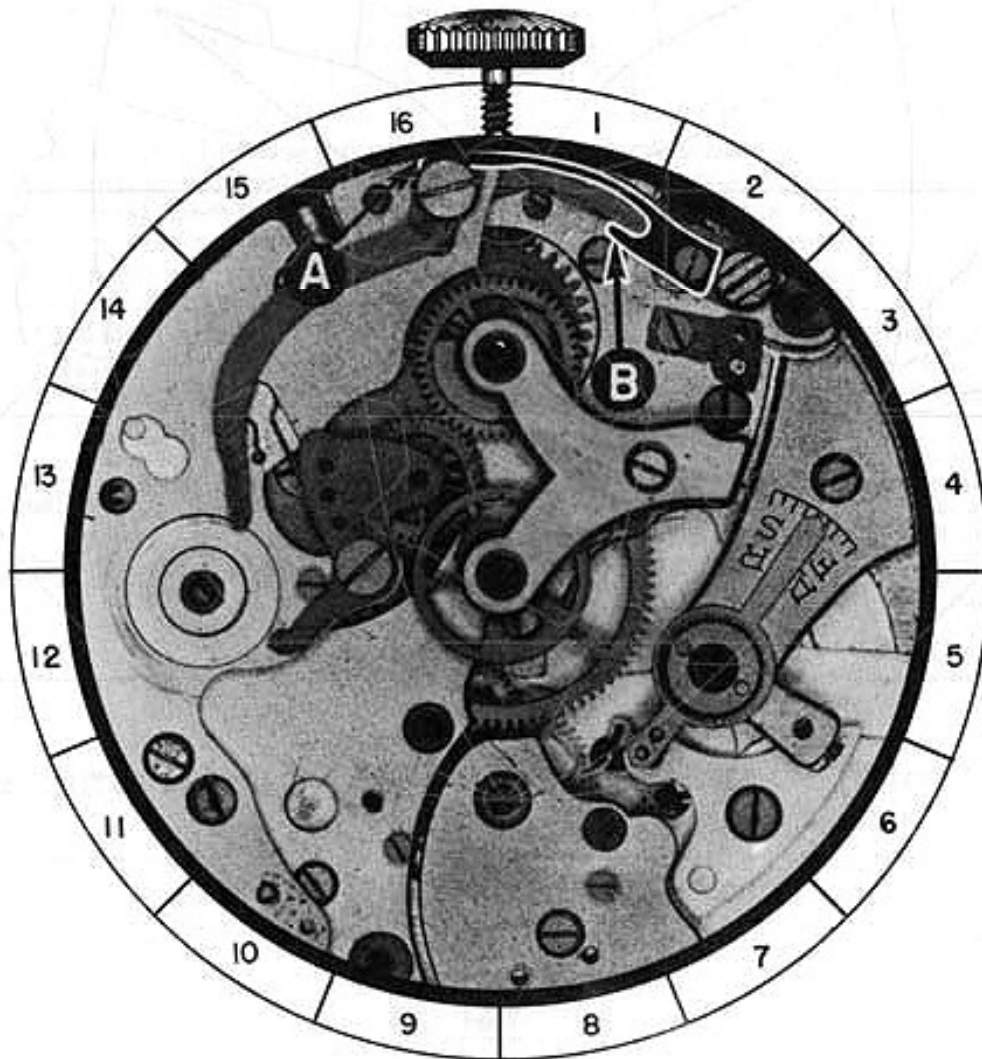

10-A

PART NO. 11

A. DISASSEMBLY PROCEDURE OF FLYBACK ACTUATING LEVER:

This lever is held in place by shouldered screw SS-3, and may be lifted from the plate when screw is removed.

(The shape of the screw for this part is shown at the bottom of the page.)

B. ASSEMBLY PROCEDURE OF FLYBACK ACTUATING LEVER:

Place this lever in its proper position with the hole in the lever over the screw hole in the end of the flyback actuating push piece. In order to line up the screw hole, the flyback actuating push piece must be pushed inward. Now replace shouldered screw SS-3. After screw is replaced, check to see that the flyback actuating lever pivots freely under the head of this screw.

C. FUNCTION OF FLYBACK ACTUATING LEVER:

When the flyback actuating lever is pushed in, the end "A" of the lever (see illustration 1) contacts the surface "D" on the underside of the flyback lever. The end "A" then slides across the surface "D" of the flyback lever until it reaches the corner where surface "E" and "D" meet. (As shown by the dotted actuating lever.) The pressure of this actuating lever on this corner will cause the flyback lever to pivot in the direction of the arrow, to such an extent that the flyback lever spring "H" will move into notch "K" as shown in illustration 2. This will engage the chronograph mechanism.

When the flyback actuating lever is pushed in for the second time, due to the changed position of the flyback lever, the end "A" (see illustration 2) will now contact the surface "F" on the underside of the flyback lever. The end "A" will then slide along this surface until it reaches the corner where surface "G" and "F" meet (as shown by the dotted lever.) The pressure of the actuating lever on this corner will cause the flyback lever to pivot in the direction of the arrow to such an extent that the flyback lever spring "H" will move into notch "J" as shown in illustration 1. This will disengage the chronograph mechanism.

REMARKS:

In order to see the function of the flyback actuating lever in relation to the flyback lever there is a peephole "F" (see page 4). By looking through this hole which is provided for this purpose, the functioning of these parts can be more easily observed.

REFERENCE: Flyback actuating push piece is Assembly 12.

OILING

The shouldered screw SS-3 on which the flyback actuating lever pivots, should be slightly moistened with oil.



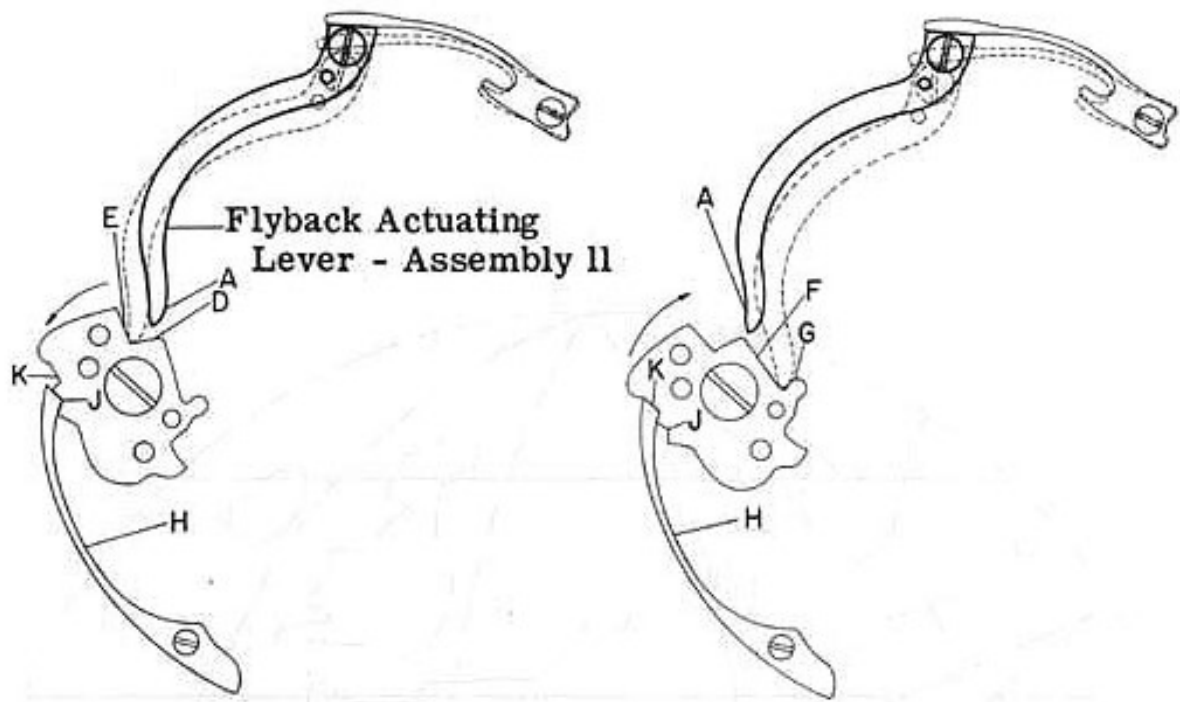
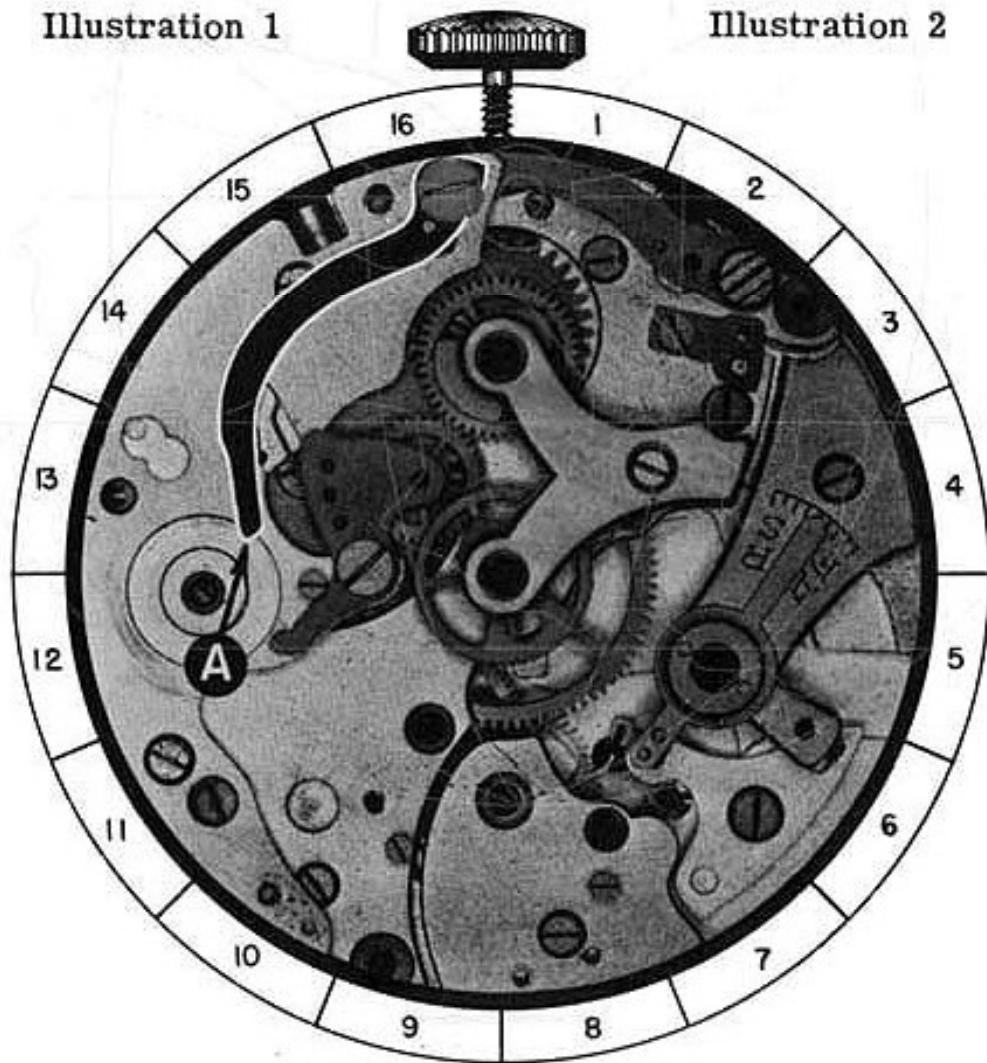

Illustration 1

Illustration 2



11-A

PART NO. 12

A. DISASSEMBLY PROCEDURE OF FLYBACK ACTUATING PUSH PIECE

This push piece is held in place by left thread shouldered screw SS-4. After screw is removed the end "A" of push piece must be slid from underneath the assembly plate and lifted out of place.

(The shape of screw for this part is shown at the bottom of the page.)

B. ASSEMBLY PROCEDURE OF FLYBACK ACTUATING PUSH PIECE:

Place this push piece in its proper position on the plate. Now force the push piece in, until the hole is lined up with the screw hole in the plate. Replace left thread shouldered screw SS-4. The left thread shouldered screw can be identified by the grooves running parallel to the screw slot.

C. FUNCTION OF THE FLYBACK ACTUATING PUSH PIECE.

This push piece when pushed, will pivot on the shouldered screw SS-4, and since the flyback actuating lever is connected to this push piece by a shouldered screw, the flyback actuating lever is moved to contact the flyback lever. The effect of the flyback actuating lever on the flyback lever is shown on page 11.

REMARKS:

Many parts of the chronograph mechanism that pivot or turn to perform their function, are held in place by shouldered screws. Each of these parts should be checked to see that the shoulder of the screw properly fits the part. After replacing each of these parts in the chronograph, they should be checked by holding the part with tweezers to see if the part has proper endshake and sideshake; also check at the same time to see that the part is free and not binding. The improper fit of a part to the shoulder of a screw can many times prevent the proper functioning of a part. This makes it absolutely necessary that each part that works under the head of a screw be carefully checked.

REFERENCE: Chronograph assembly plate is Assembly 19.
Flyback actuating lever is Assembly 11.
Flyback lever is Assembly 4.

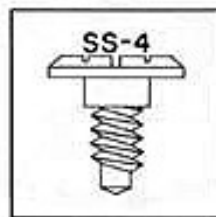

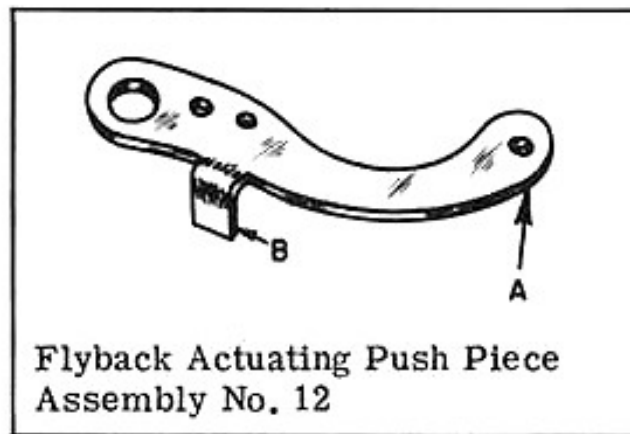

OILING

The following locations on the flyback actuating push piece should be moistened with oil.

1. Location "B" at point of contact with push piece spring.
2. Shouldered screw SS-4 on which the flyback actuating push piece pivots.

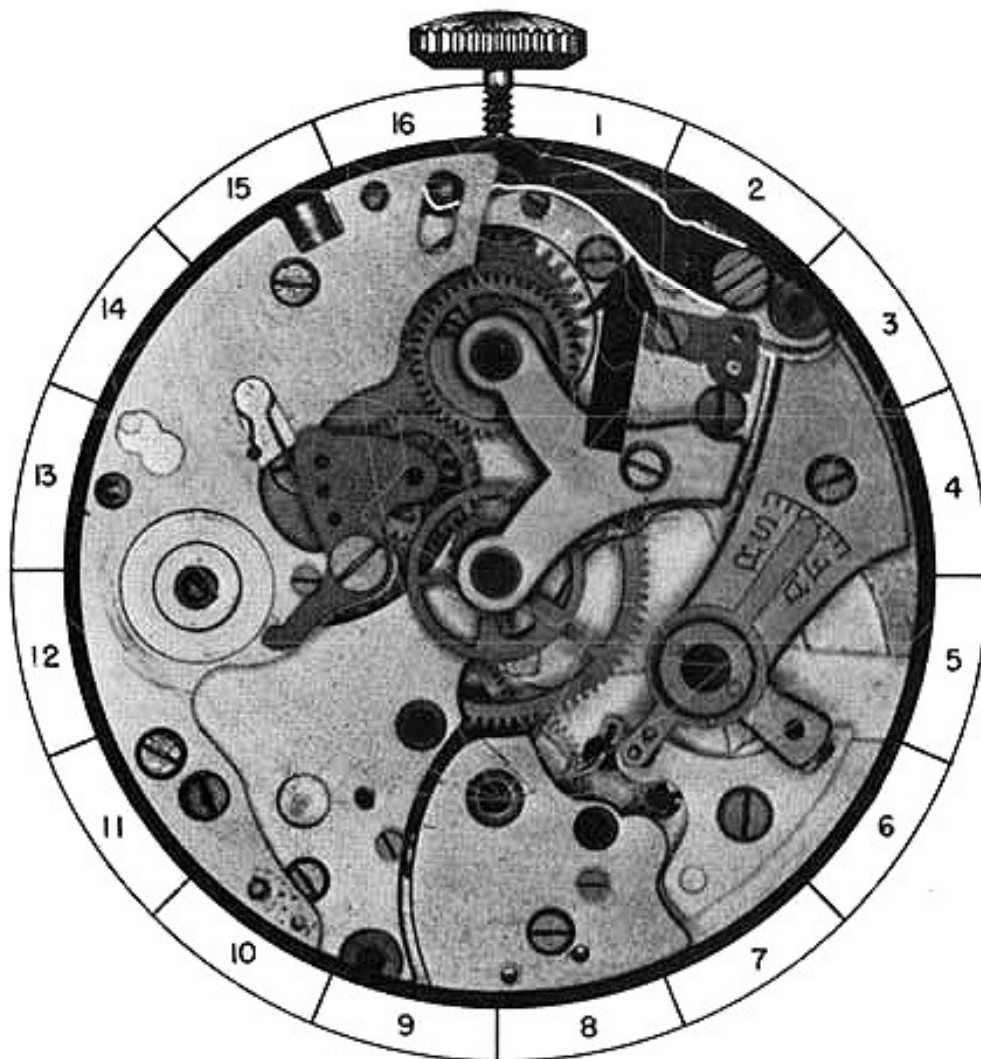

12-A

PART NO. 13

A. DISASSEMBLY PROCEDURE OF SECONDS WHEEL AND MINUTE REGISTER WHEEL BRIDGE:

This bridge is held in place by fillister head screw FS-7, and steady pins. Remove screw and loosen bridge from plate by sliding a thin-bladed screwdriver between bridge and plate. When steady pins are free in plate, bridge may be lifted out of place.

(The shape of screw for this part is shown at bottom of page.)

B. HAZARDS IN DISASSEMBLY OF SECONDS WHEEL AND MINUTE REGISTER WHEEL BRIDGE:

When removing bridge from plate, avoid twisting of bridge, as this may damage pivots on wheels or chip the jewels in the bridge. The screwdriver should be carefully used to prevent marring of bridge or plate.

C. ASSEMBLY PROCEDURE OF SECONDS WHEEL AND MINUTE REGISTER WHEEL BRIDGE:

Place this bridge on the plate, with the steady pins over the proper holes in the plate. Place top pivots of seconds wheel and minute register wheel, so that they will enter the jewel holes in the bridge. Bridge may now be pressed down to proper place with back of tweezers, and fillister head screw FS-7 replaced.

D. FUNCTION OF SECONDS WHEEL AND MINUTE REGISTER WHEEL BRIDGE:

The function of this bridge is to provide a bearing surface for the top pivots of the seconds wheel and minute register wheel.

REMARKS:

The heart on the seconds wheel and minute register wheel must be highly polished, as any roughness or pits of rust may prevent the flyback lever from returning these wheels to a zero position. When polishing the heart, care should be taken that shape of heart is not changed. The heart on these wheels should be tested to see that they are tight on the wheel. The heart being loose on the wheels may result in one or both of these wheels not returning to a zero position, when the flyback lever is brought in contact with the hearts. (For instructions on polishing the heart, see Volume 24, Part 1, Page 11.)

REFERENCE: Seconds wheel is Assembly 15.
Minute register wheel is Assembly 14.
Flyback lever is Assembly 4.

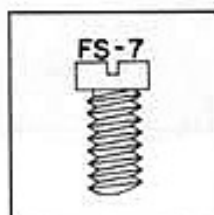

Assembly No. 13



Seconds Wheel and
Minute Register Wheel
Bridge

OILING

The pivots in the jewels in the bridge should be oiled as you would properly oil a train pivot in a watch.

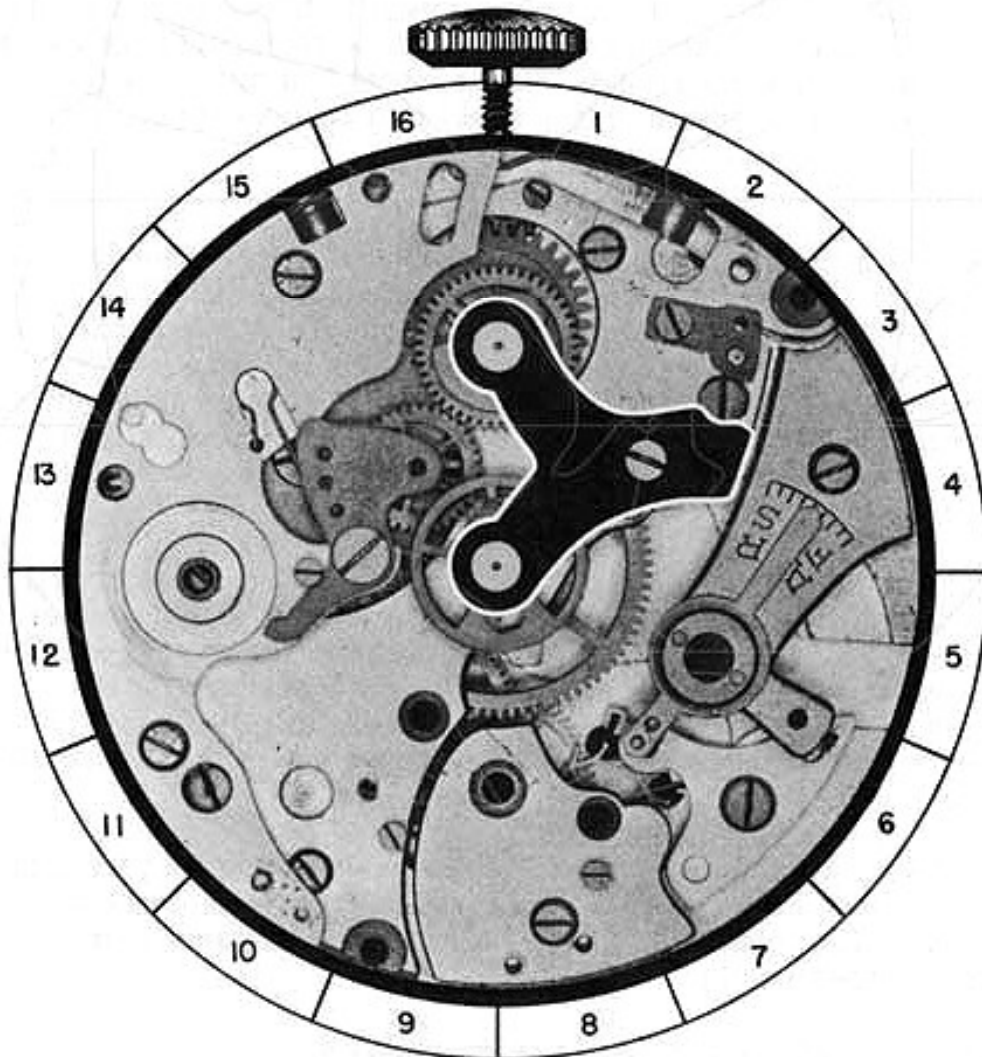

13-A

PART NO. 14

A. DISASSEMBLY PROCEDURE OF MINUTE REGISTER WHEEL:

To remove this wheel, simply lift it out of place.

B. HAZARDS IN DISASSEMBLY OF MINUTE REGISTER WHEEL:

When removing this wheel, lift wheel straight up out of watch, as any twisting may bend or break the pivot on the minute register wheel.

C. ASSEMBLY PROCEDURE OF MINUTE REGISTER WHEEL:

Place the minute register wheel in its proper position in the watch, as shown on the photograph, with the long post "B" of this wheel down in pivot hole in plate.

D. FUNCTION OF MINUTE REGISTER WHEEL:

The function of the minute register wheel is to record the minutes that have elapsed since the beginning of the registration of the chronograph sweep second hand. The heart "A" of minute register wheel is used in returning this wheel to a zero position.

REMARKS:

The minute register wheel is returned to a zero position by the flyback lever contacting the heart on minute register wheel. The heart on this wheel is set eccentric. When the flat end of flyback lever contacts the eccentric heart, it forces the heart to turn. The heart will turn until the flat end of flyback lever sets across the two lobes at top of heart. With the pressure equalized at these two points, it will turn no further and this would be a zero position.

If this wheel has turned less than 160 degrees from a zero position when the flyback lever is brought in contact with the heart, it will turn in the opposite direction to which it was turning to bring this wheel back to a zero position. On the other hand, if the wheel is turned past 160 degrees from a zero position, the flyback lever will force the heart to continue to turn in the direction it was turning, until it reaches a zero position.

The degree used above is approximate, as this degree varies in most chronographs from 150 to 170 degrees. For more detail information on the returning to zero mechanism see Volume 24, Part 1, Pages 1 to 10.

REFERENCE: Flyback lever is Assembly 4.

Minute Register Wheel
Assembly No. 14

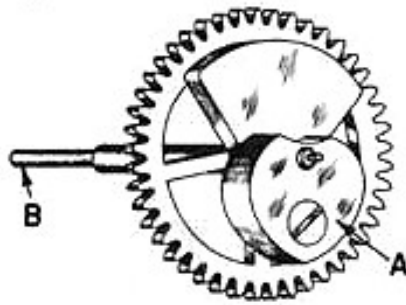

OILING

The top and bottom pivots on minute register wheel should be oiled after bridge for this wheel is replaced in the watch. Oil these pivots as you would properly oil the train pivots in a watch.

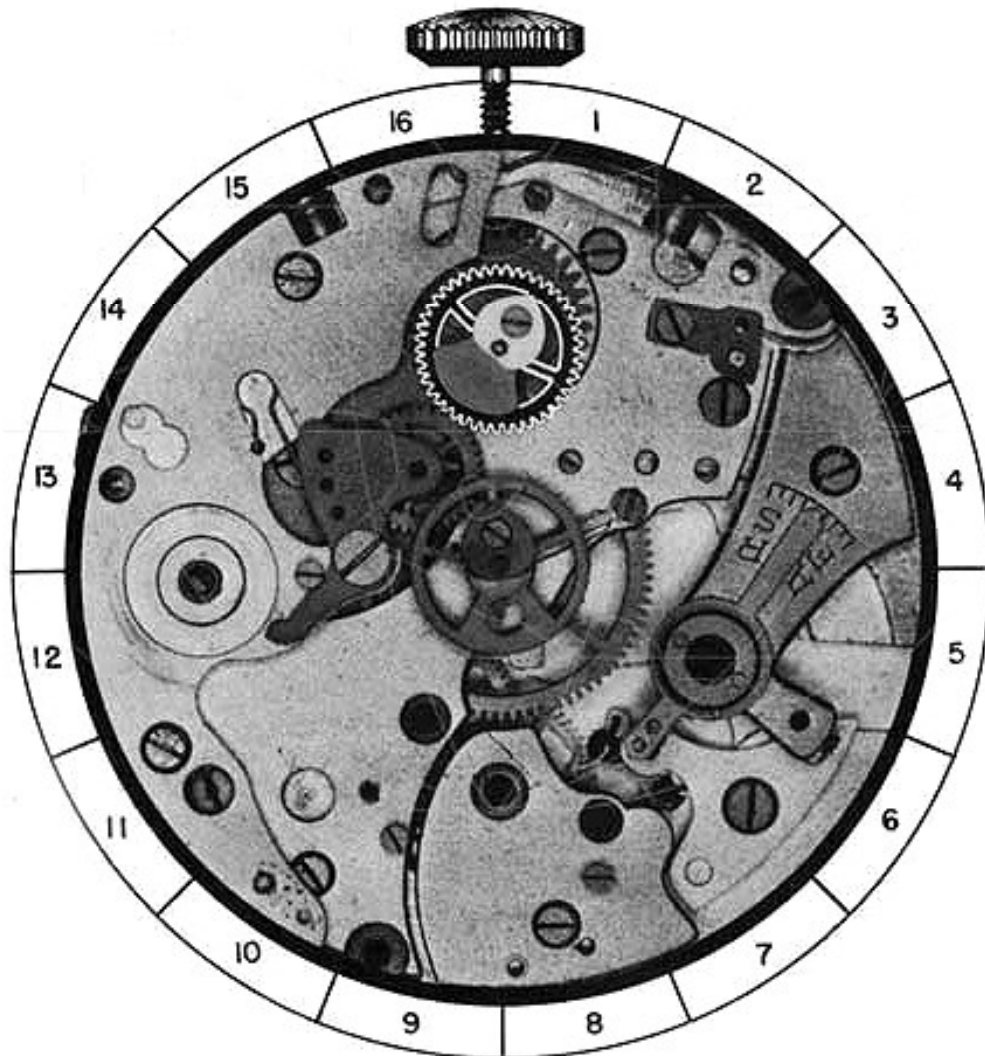

14-A

PART NO. 15

A. DISASSEMBLY PROCEDURE OF SECONDS WHEEL:

The seconds wheel is lifted out of place to remove it.

B. HAZARDS IN DISASSEMBLY OF SECONDS WHEEL:

Lift seconds wheel straight up when removing it. Any tilting of wheel may bend the pivot.

C. ASSEMBLY PROCEDURE OF SECONDS WHEEL:

Place wheel in its proper position with the long pivot "A" down in hollow center wheel pinion.

D. FUNCTION OF SECONDS WHEEL:

The functions of the seconds wheel are as follows;

1. The seconds wheel registers passage of seconds on the dial. This is done by a hand being attached to the long pivot "A" on seconds wheel.
2. The seconds wheel must move the minute register wheel forward one tooth, each time the seconds wheel makes one revolution. This is done by a dart tooth "C" attached to the seconds wheel. This dart tooth meshes with the teeth on intermittent wheel which, in turn, moves the minute register wheel one tooth.
3. The seconds wheel must return to a zero position when the flyback lever is brought in contact with the heart on this wheel. Seconds wheel heart is shown as "B" on isometric drawing.

REMARKS:

When the flyback lever is forced towards the center of the watch, and held at this position, check the seconds wheel and minute register wheel to see if either of these wheels will turn. The minute register wheel should turn slightly at this point, but the seconds wheel should be held very tight by the flyback lever. It is most essential for the seconds wheel to be held stationary by the flyback lever at a zero position. In the case of the minute register wheel, it does not have to be held absolutely stationary by the flyback lever, as the minute register pawl will serve this purpose. The only thing that the minute register wheel should be checked for is to see that the minute register wheel will not turn far enough to one side or to the other to let the minute register pawl drop into another tooth. This will assure that the minute register wheel will always be brought back to a zero position.

The advantage of having the minute register wheel turn slightly when the flyback lever is brought into the center of the watch is to prevent any wearing of these parts from affecting the exact zero returning of the seconds wheel.

REFERENCE: Flyback lever is Assembly 4.
Intermittent wheel is shown on Page 18.

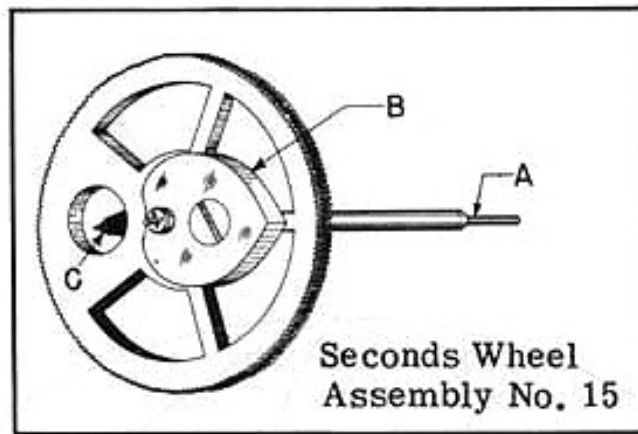

OILING

The top pivot on the seconds wheel should be oiled after bridge for this wheel is replaced. The lower pivot close to the shoulder should be moistened with oil before the seconds wheel is replaced.

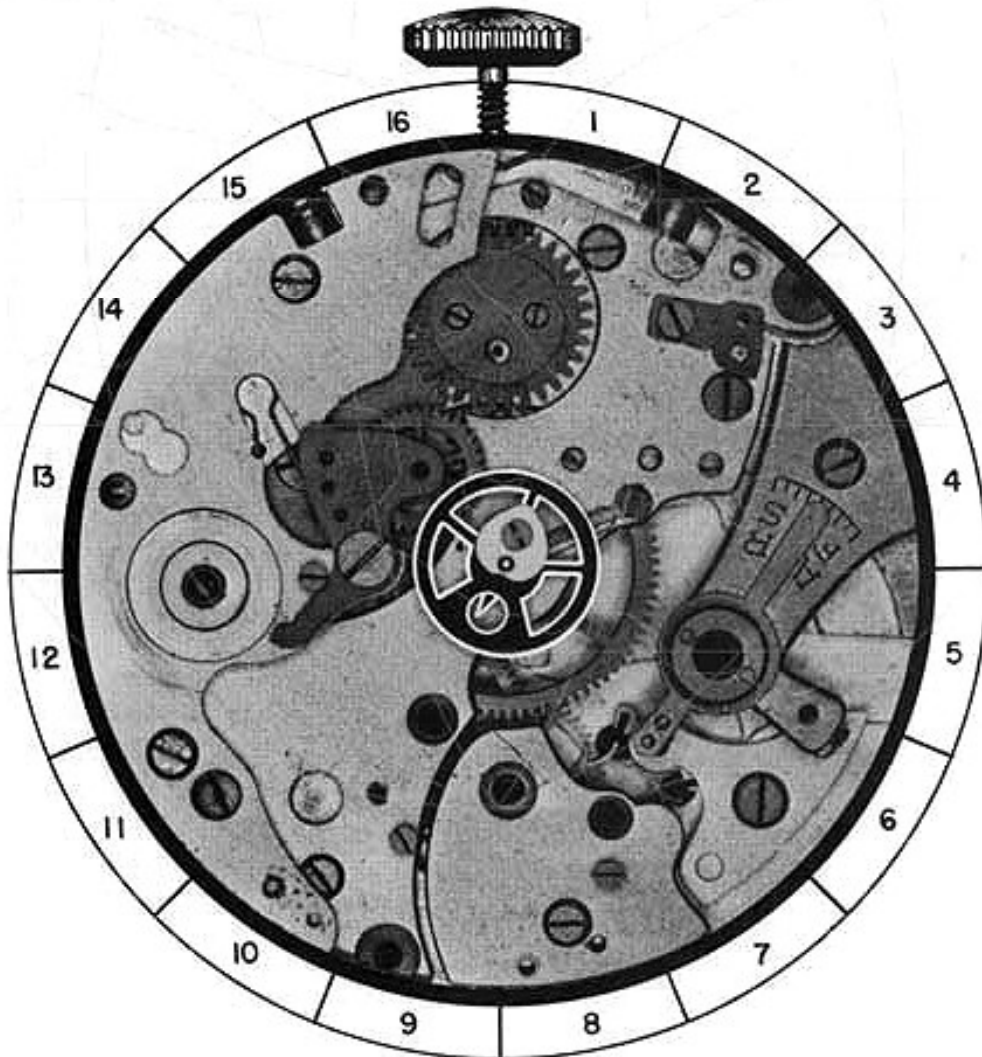

15-A

PART NO. 16

A. DISASSEMBLY PROCEDURE OF SECONDS WHEEL TENSION SPRING:

The seconds wheel tension spring is held in place by fillister head screw FS-8. When this screw is removed, the tension spring will be free on the plate and can be removed.

(The shape of screw for this part is shown at bottom of page.)

B. HAZARDS IN DISASSEMBLY OF SECONDS WHEEL TENSION SPRING:

Be careful in removing this spring. It is a very thin soft spring, and easily bent.

C. ASSEMBLY PROCEDURE OF SECONDS WHEEL TENSION SPRING:

Place the spring in its proper position on the plate, with the hole in the spring over the proper screwhole. (Be certain that the right side of the spring is up, so that end "A" rises above the level of the plate.) Now replace fillister head screw FS-8, but before tightening this screw, place the end "A" of spring centered over the hole in the hollow pinion of the center wheel. Another method for checking to see that the tension spring is properly centered over the hole, is to turn the chronograph over to the dial side and look through the hollow center wheel pinion. If the tension spring is not centered sufficiently, it will be easily detected.

D. HAZARDS IN ASSEMBLY OF SECONDS WHEEL TENSION SPRING:

The seconds wheel tension spring is a soft thin spring, and easily mutilated. Use care in replacing it.

E. FUNCTION OF SECONDS WHEEL TENSION SPRING:

1. This spring holds a tension on the seconds wheel so that while the wheel is turning, it has a smooth action, with no irregular jumping or jerking.
2. The second purpose of this spring is to act as a brake to hold the seconds wheel in a stationary position when the seconds wheel is completely free from the chronograph mechanism.

REMARKS:

The tension that this spring holds on the seconds wheel should be properly adjusted, so that it is neither too strong nor too weak. If the seconds hand moves forward with an irregular motion, the tension of the spring must be increased. If the oscillation of the balance wheel decreases noticeably when the chronograph mechanism is engaged, in spite of the chronograph wheels being free, then the tension of the spring must be decreased.

REFERENCE: Seconds wheel is Assembly 15.

(For more detailed information in regards to setting the tension of the seconds wheel tension spring, refer to Volume 24, Part 8 of the Esembl-O-Graf Library.)

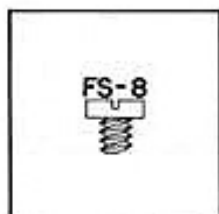



Seconds Wheel Tension Spring
Assembly No. 16

OILING

The seconds wheel tension spring should not be oiled.

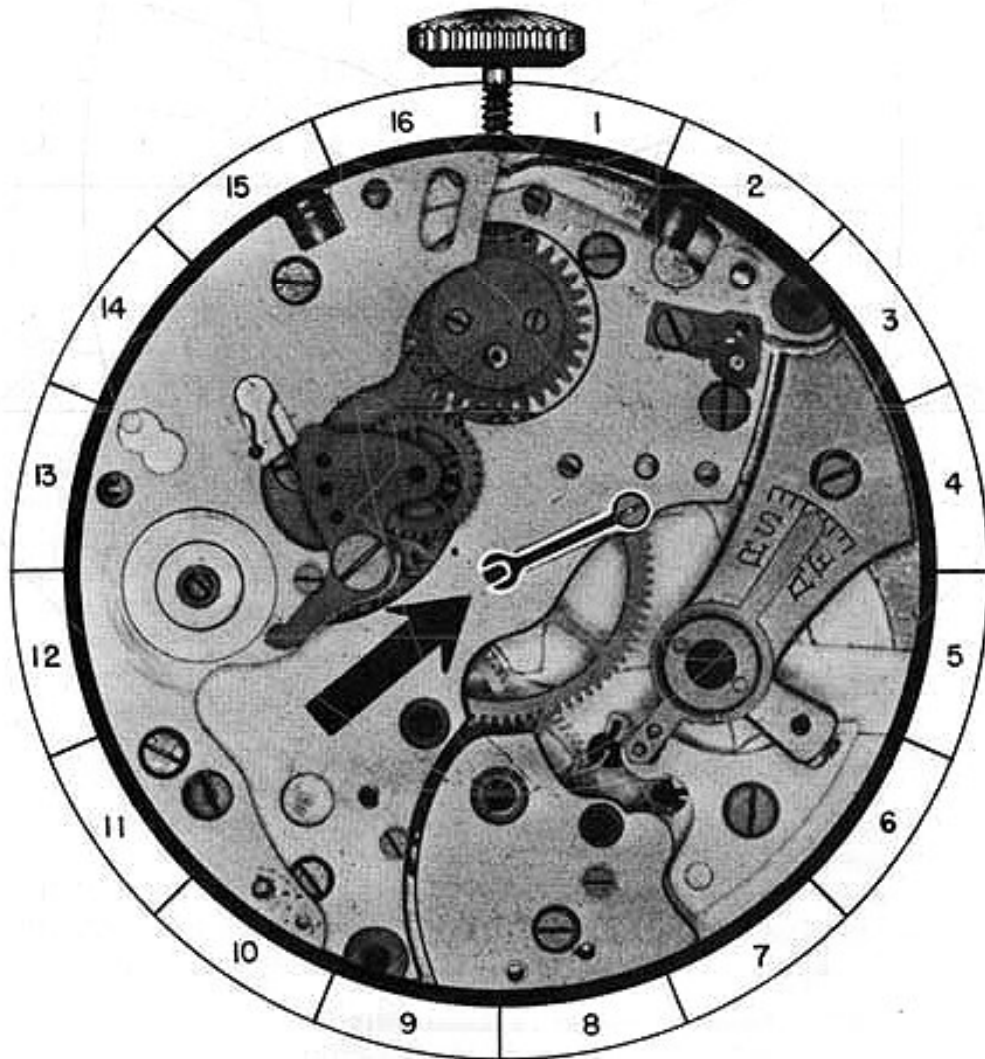

16-A

PART NO. 17

A. DISASSEMBLY PROCEDURE OF INTERMITTENT LEVER SPRING:

This spring is held in place by a recess in the plate. To remove this spring grip end "A" with a pair of tweezers and lift up.

B. HAZARDS IN DISASSEMBLY OF INTERMITTENT LEVER SPRING:

Hold finger over spring when removing it to eliminate the chance of it shooting away.

C. ASSEMBLY PROCEDURE OF INTERMITTENT LEVER SPRING:

Grip the end "A" of spring with a pair of tweezers. Now place the end "B" of spring in its proper position in the recess in the plate. Now move the end "A" of the spring in the direction to contract the loop in the spring, to the extent that it can be easily pushed down into the recess. The end "A" of this spring fits on the lip "A" on the side of the intermittent lever.

D. FUNCTION OF INTERMITTENT LEVER SPRING:

The function of this spring is to hold a tension on the intermittent lever. This tension forces the intermittent lever to pivot, moving the intermittent wheel to a position which will permit the dart tooth to engage with the teeth on this wheel.

REMARKS:

This chronograph is an economy model. In order to keep down the expense of production, it was necessary to reduce the number of chronograph parts. In this chronograph, comparing it to the other models, the castle wheel, the castle wheel pawl, and the brake lever are eliminated. Since this chronograph has no castle wheel, it is designed so that the flyback lever can perform the functions that would ordinarily be performed by the castle wheel. In regards to the brake lever, which has also been eliminated, there is no part that is substituted. For this reason, if the chronograph is disengaged and the watch is bumped, the sweep hand may move from its original position, because there is no brake lever to hold the seconds wheel from turning. The only thing that can be done to help reduce this error is to add a little stronger tension on the seconds wheel tension spring. It must be kept in mind that the tension cannot be increased too much as this will effect the oscillation of the balance when the chronograph is registering, and therefore effect the time keeping qualities of the watch. For obvious reasons this model chronograph is referred to as a non-castle wheel type.

REFERENCE: Seconds wheel is Assembly 15.
Intermittent wheel is Assembly 18.

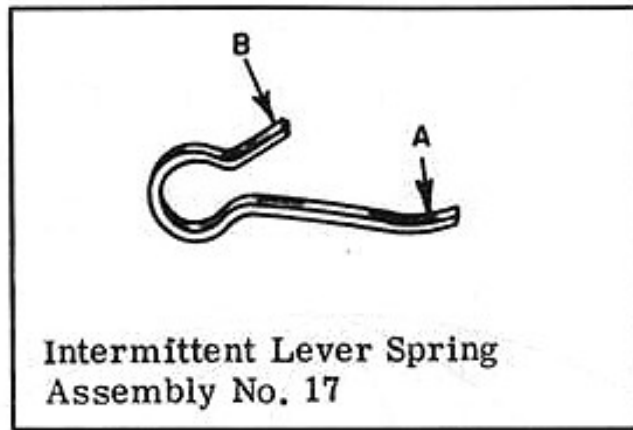

OILING

The end "A" of the intermittent lever spring should be slightly moistened with oil.

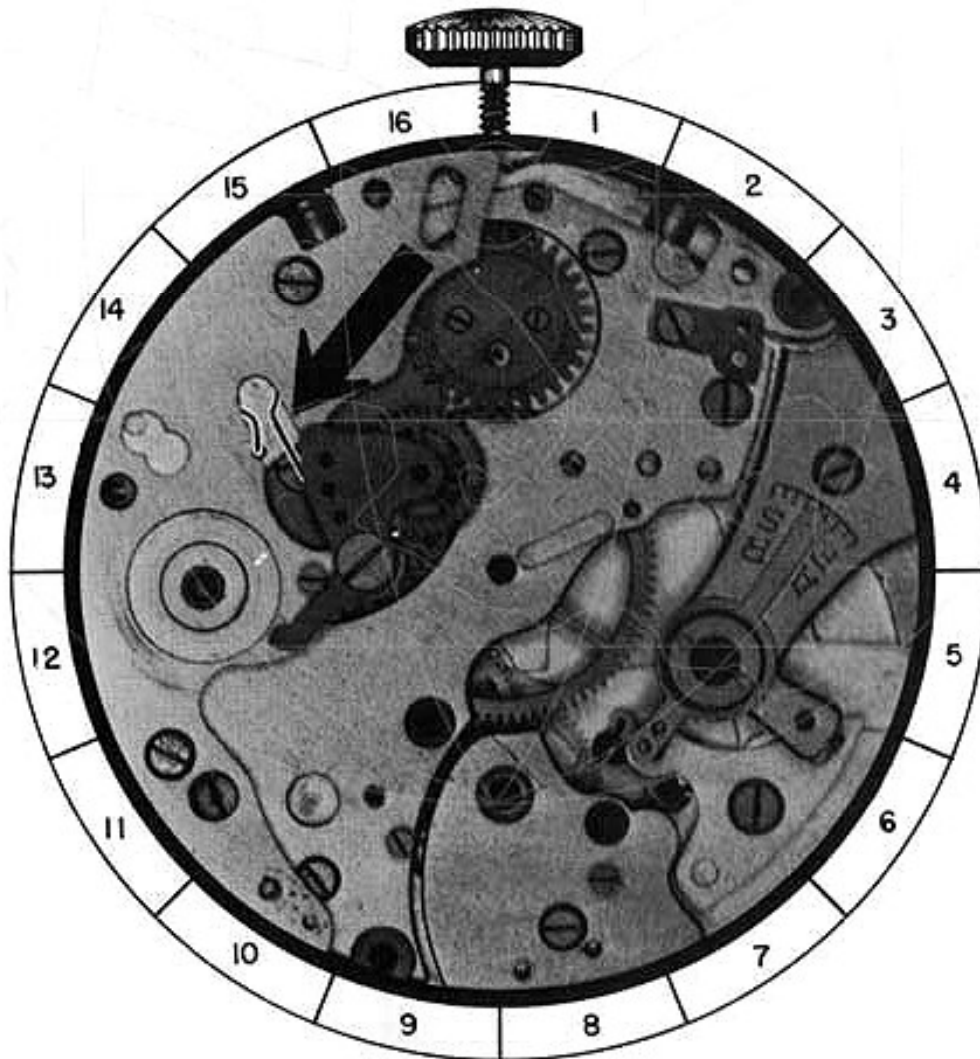

17-A

PART NO. 18

A. DISASSEMBLY PROCEDURE OF INTERMITTENT LEVER AND WHEEL ASSEMBLY:

This assembly is held in place by shouldered screw SS-5. When this screw is removed this assembly can be lifted out of place.

(The shape of screw for this part is shown at bottom of page.)

B. ASSEMBLY PROCEDURE OF INTERMITTENT LEVER AND WHEEL ASSEMBLY:

Place the intermittent lever and wheel assembly in its proper position on the plate. Replace shouldered screw SS-5. After screw is replaced, check to see that intermittent lever pivots freely on this screw.

C. FUNCTIONS OF INTERMITTENT LEVER AND WHEEL ASSEMBLY:

The function of the intermittent lever is to engage and disengage the intermittent wheel with the seconds wheel dart tooth.

The function of the intermittent wheel is to transfer the power from the dart tooth to the minute register wheel.

REMARKS:

The intermittent wheel should be carefully checked to see that it has proper endshake and spins freely in the intermittent lever. This wheel must spin freely, as any excess friction on the intermittent wheel may cause the following errors:

1. An incorrect registration of the minutes on the dial.
2. The minute register pawl setting at an incorrect position on minute register wheel.
3. It may cause the watch to stop due to the dart tooth being unable to turn the intermittent wheel.

(For more complete information on the minute register mechanism see Volume 24, Part 6.

REFERENCE: Seconds wheel is Assembly 15.
Intermittent lever spring is Assembly 17.

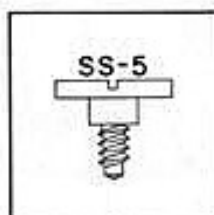

Intermittent Lever and
wheel Assembly
Assembly No. 18

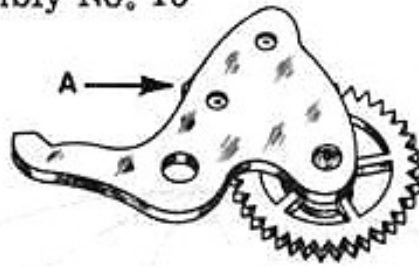

OILING

The shouldered screw SS-5 on which the intermittent lever pivots should be slightly moistened with oil.

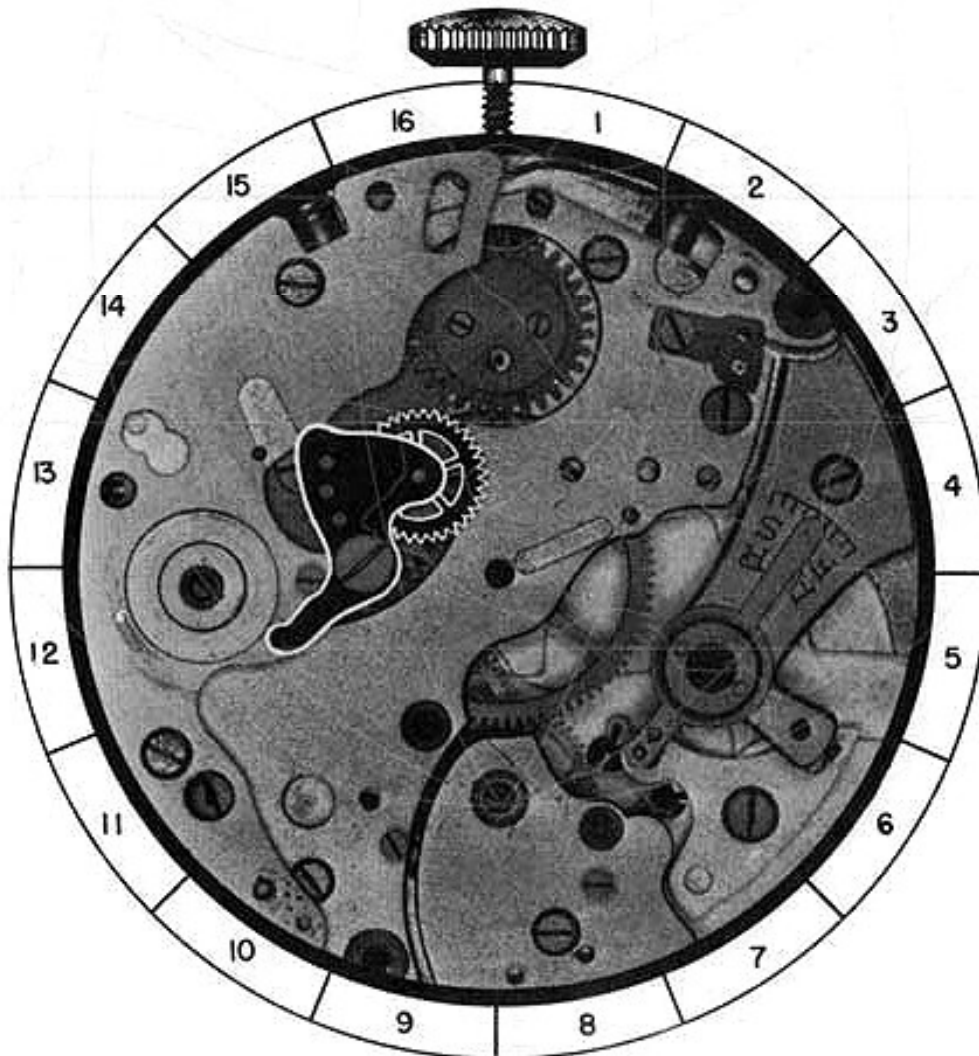

18-A

PART NO. 19

A. DISASSEMBLY PROCEDURE OF CHRONOGRAPH ASSEMBLY PLATE:

This assembly plate is held in place by two identical fillister head screws FS-9 and FS-10. The position of these screws are shown on the photograph. After these screws are removed, slide a finely sharpened screwdriver under this plate to loosen it from the movement. After assembly plate is free, it can be lifted out of place.

(The shape of screws for this part is shown at bottom of page.)

B. HAZARDS IN DISASSEMBLY OF CHRONOGRAPH ASSEMBLY PLATE:

When loosening this plate from movement by sliding a finely sharpened screwdriver under this plate, care should be taken so as not to mar the assembly plate or the movement plate.

C. ASSEMBLY PROCEDURE OF CHRONOGRAPH ASSEMBLY PLATE:

Place the assembly plate in its proper position in the movement as shown in the photograph. Now see that the steady pins are entering their proper holes in the movement and press the plate down in place. Replace fillister head screw FS-9 and FS-10 in the positions as indicated in the photograph.

D. FUNCTION OF CHRONOGRAPH ASSEMBLY PLATE:

This plate provides a support for part of the chronograph mechanism.

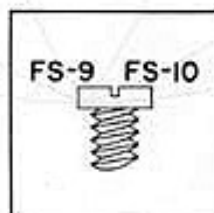



Chronograph Assembly Plate
Assembly No. 19

OILING

The chronograph assembly plate should not be oiled.

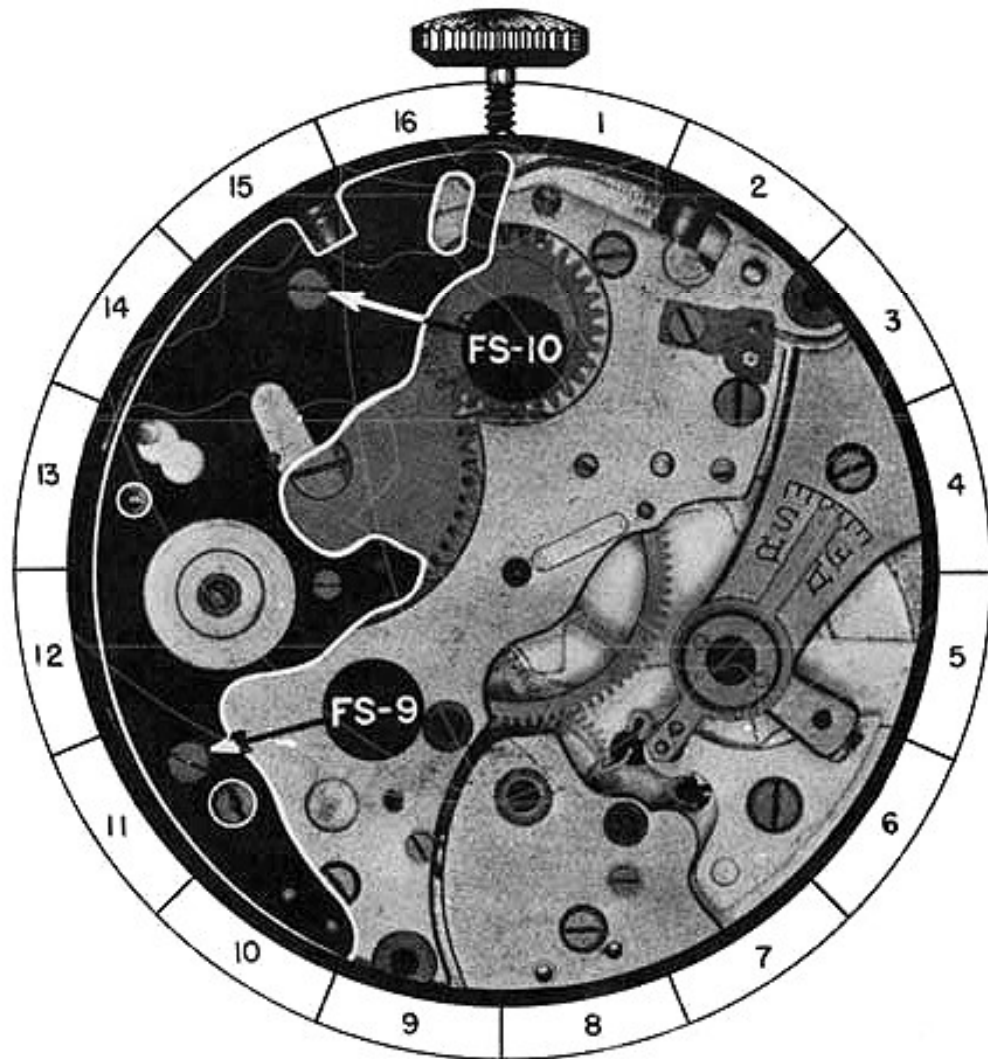

19-A

PART NO. 20

A. DISASSEMBLY PROCEDURE OF PUSH PIECE SPRING:

To remove this spring grip the end "A" or "B" with a pair of tweezers and lift this spring out of place.

B. HAZARDS IN DISASSEMBLY OF PUSH PIECE SPRING:

When removing this spring, hold your finger over it to eliminate the hazard of this spring shooting away.

C. ASSEMBLY PROCEDURE OF PUSH PIECE SPRING:

Place the end "B" of spring in its proper position in the recess in the plate. Now move end "A" of spring so that it can be placed in the recess, as shown in the photograph. The tension of this spring on the stud and against the edges of the plate will hold the spring in place until the chronograph assembly plate is replaced.

(Chronograph assembly plate is assembly 19.)

D. FUNCTION OF PUSH PIECE SPRING:

The function of this spring is to return the push piece for setting back to zero and the flyback actuating push piece to their original position, after these push pieces have been operated.

REFERENCES: Push piece for setting back to zero is Assembly 9.
Flyback actuating push piece is Assembly 12.

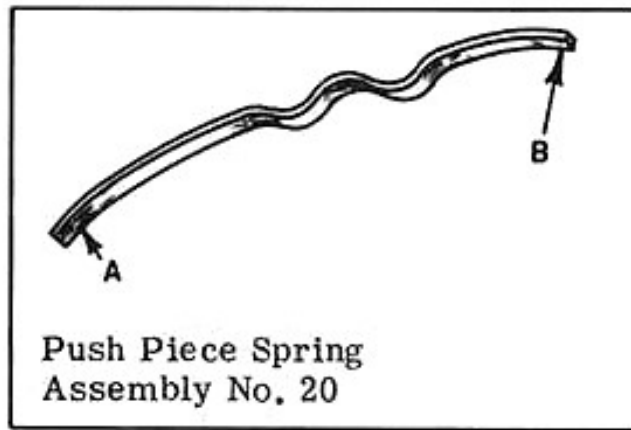

OILING

The push piece spring will be oiled later.

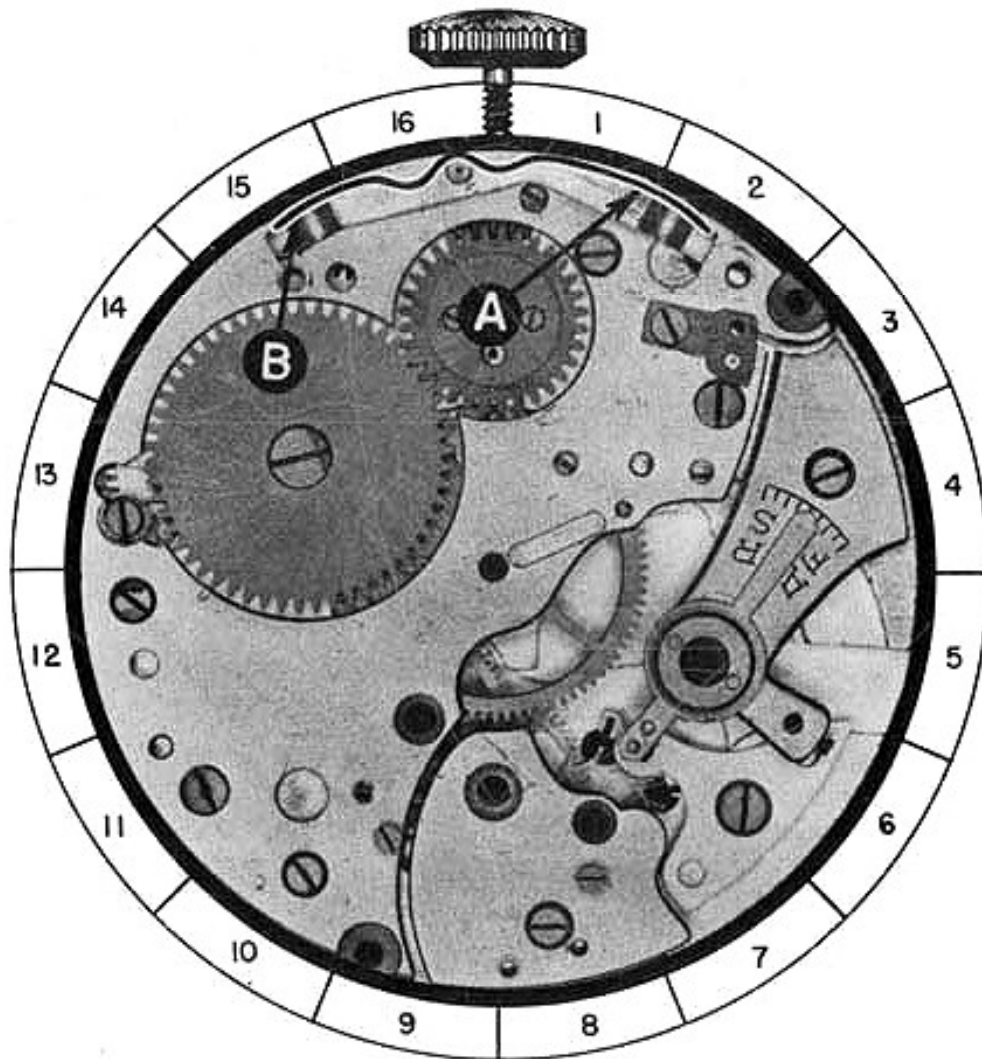

20-A

FUNCTIONAL RESULTS

After completely assembling the chronograph, check to see that the parts function correctly. Below are listed a number of functional results that should occur, along with the most common errors that will prevent the proper function of the chronograph.

1. PUSH THE BUTTON AT THE LEFT OF THE PENDANT TO RETURN THE HEARTS TO A ZERO POSITION AND CHECK THE FOLLOWING:

- A. Check to see that end "C" of the flyback lever is holding the heart at an exact zero position.

CORRECTION: The flyback lever spring not holding enough tension on the flyback lever may result in end "C" of the flyback lever failing to hold the heart at an exact zero position. Also the branch "C" of the flyback lever being too short will result in the same error.

- B. Check to see that with the seconds wheel held stationary by the flyback lever that the minute register wheel can turn slightly.

CORRECTION: The branch "D" of the flyback lever being too long will prevent the minute register wheel from turning slightly at a zero position.

(For more detailed information on the returning to zero function, see Volume 24, Pages 1 to 10.)

- C. Check to see that end "A" of minute register pawl lies centered between two teeth on the minute register wheel. Failure to have this pawl adjusted properly will result in the minute register hand moving after the flyback lever is moved away from the heart on this wheel.

CORRECTION: Adjust the minute register pawl so that the end "A" of the pawl lies directly between two teeth on the minute register wheel, when this wheel is at a zero position.

(For more detailed information on the minute register mechanism, see Volume 24, Part 6, Pages 41 to 81.)

2. PUSH THE BUTTON AT THE RIGHT OF THE PENDANT, RELEASE IT AND CHECK THE FOLLOWING:

- A. Check to see that the intermediary wheel is properly engaged with the seconds wheel.

CORRECTION: The following errors could prevent the intermediary wheel from properly engaging with the seconds wheel:

- a. The chronograph pivoted detent not pivoting freely.
- b. The chronograph pivoted detent spring not holding enough tension on the chronograph pivoted detent to force the intermediary wheel to engage fully.
- c. The flyback lever not moving to its proper position will cause improper engagement of these wheels
- d. Improperly adjusted eccentric studs.

(See adjustment of eccentric studs in front of book.)

(Continued on next page)

FUNCTIONAL RESULTS
(Continued)

- B. Check to see that the dart tooth on the seconds wheel engages properly with the teeth on the intermittent wheel.

CORRECTION: The following errors could prevent the dart tooth on the seconds wheel from engaging properly with the teeth on the intermittent wheel:

- a. The intermittent lever spring not holding enough tension on the intermittent lever to force the intermittent wheel to engage with the dart tooth.
- b. Intermittent lever and wheel assembly not pivoting freely.
- c. Improperly adjusted eccentric studs.
(See adjustment of eccentric studs in front of book.)

- C. Check to see that the sweep second hand moves forward in a steady manner, with no irregular jumping or jerking.

CORRECTION: Any irregular movement of the sweep seconds hand is usually caused by the seconds wheel tension spring not holding enough tension on the seconds wheel. (for more detailed information on setting the proper tension of the seconds wheel tension spring see Volume 24, Part 8, Page 82.)

- D. Check the minute register hand to see that it moves forward exactly one minute each time the sweep second hand passes 60 seconds of registration.

CORRECTION: Failure of the minute register hand to move forward exactly one minute each time the sweep second hand makes one revolution may be caused by the following errors:

- a. Improper tension of minute register pawl on minute register wheel.
- b. The working end of the pawl not polished.
- c. Improperly fitted hands.
- d. Minute register wheel binding and not turning freely.

3. PUSH THE BUTTON AT THE RIGHT OF THE PENDANT A SECOND TIME, RELEASE IT AND CHECK THE FOLLOWING:

- A. Check to see that the intermediary wheel is disengaged from the seconds wheel.

CORRECTION: The intermediary wheel may be prevented from disengaging from the seconds wheel by the following errors.

- a. Failure of the flyback lever to move to its proper position.
- b. The chronograph pivoted detent binding and not pivoting freely.
- c. Improper adjustment of eccentric stud ES-3.

- B. Check to see that the seconds wheel remains in a stationary position and does not move, even if the watch is bumped.

CORRECTION: The seconds wheel moving and not remaining in a stationary position is usually caused by the seconds wheel tension spring not holding enough tension on the seconds wheel.

DIRECTIONS FOR READING CHRONOGRAPH DIAL

THE TACHOMETER

- A** The tachometer is used to indicate the speed of an object in miles per hour. A tachometer can only indicate the average speed of an object traveling over a course of a measured mile.

METHOD OF USING TACHOMETER

1. Start the chronograph sweep second hand at the exact moment the object starts to travel the measured distance of one mile.
2. When the object has traveled the course of one mile, stop the chronograph at the point on the tachometer scale where the sweep second hand stopped. It will indicate the average speed in miles per hour.

SPLIT SECOND SCALE

- B** This scale is divided into 300 divisions. Each indicating $1/5$ of a second every fifth division is marked with extra long lines denoting one second.

The main purpose of this scale is to measure a fraction of a second accurately.

SECOND HAND

- C** The second hand indicates the passing of seconds and should move one space each second. One complete revolution of hand denotes passage of one minute. This hand is independent of chronograph mechanism and continues to register the seconds as long as watch is running.

TELEMETER

- D** The telemeter is used to denote the number of miles between two points. This is done by comparing the speed of light to the speed of sound.

METHOD OF USING TELEMETER

1. Start chronograph sweep second hand when you see lightning.
2. Stop the chronograph sweep second hand when you hear the thunder. The point on the telemeter scale where the sweep second hand stopped will indicate the distance in miles the lightning is away from you.

MINUTE REGISTER

- E** The minute register hand indicates the passing of minutes. This hand should move forward one space each minute. One complete revolution of minute register hand indicates passage of 30 minutes. Two revolutions one hour.

THE CHRONOGRAPH DIAL

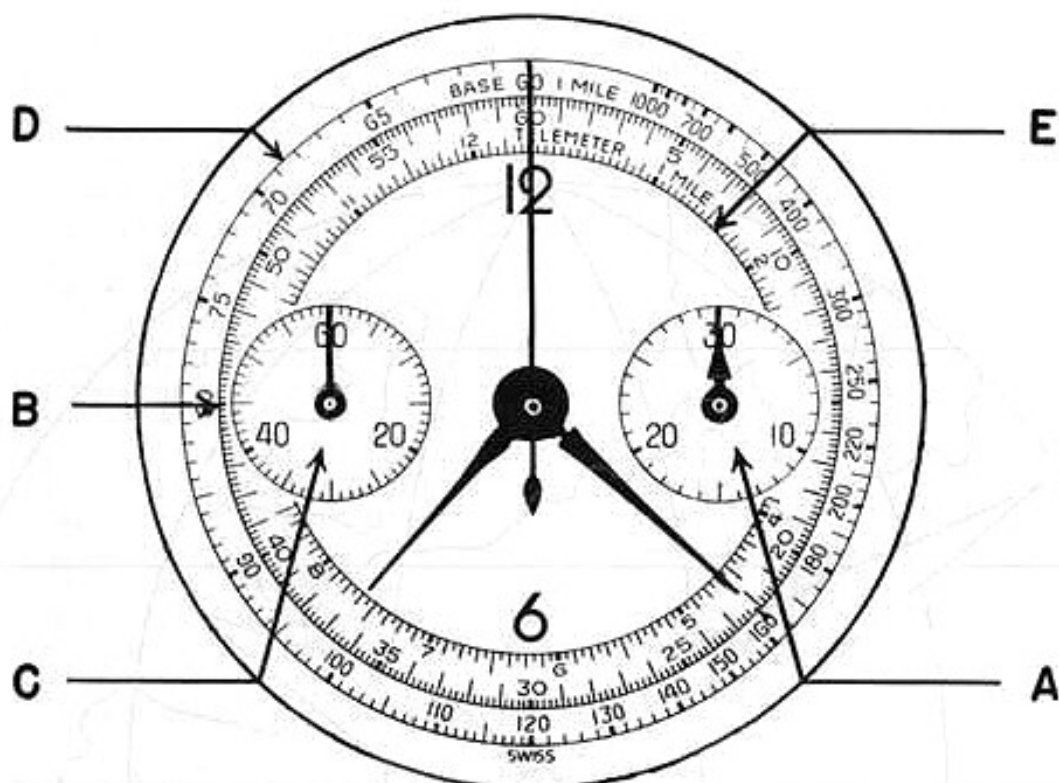

SETTING THE HANDS CORRECTLY ON A CHRONOGRAPH:

To replace the hands on a chronograph, it is advisable whenever possible to first place the chronograph in its case. With the chronograph in its case, it is easier to hold the wheels at zero, which must be done to replace the chronograph hands in their correct position. To replace the hands on a chronograph proceed as follows:

- A. Replace the hour hand, minute hand, and second hand as you would on a regular watch.
- B. Push the button to return the chronograph wheels to zero. While holding the chronograph wheels at zero, replace the minute register hand at 30 on the minute register scale "A".
- C. While still holding the wheels at zero, place the sweep second hand at 60 on the split second scale "B". The button can then be released.
- D. After the hands are replaced as directed, engage the chronograph and let it run engaged for a few minutes. At this time, check the clearance of all the hands on the chronograph. After having the chronograph run engaged, push the button to disengage the chronograph and then return the chronograph wheels to zero. Now check to see that the sweep second hand and the minute register hand return to their starting position.