

WORLD'S ONLY
FULLY ILLUSTRATED
CHRONOGRAPH WATCH COURSE
VOLUME 3

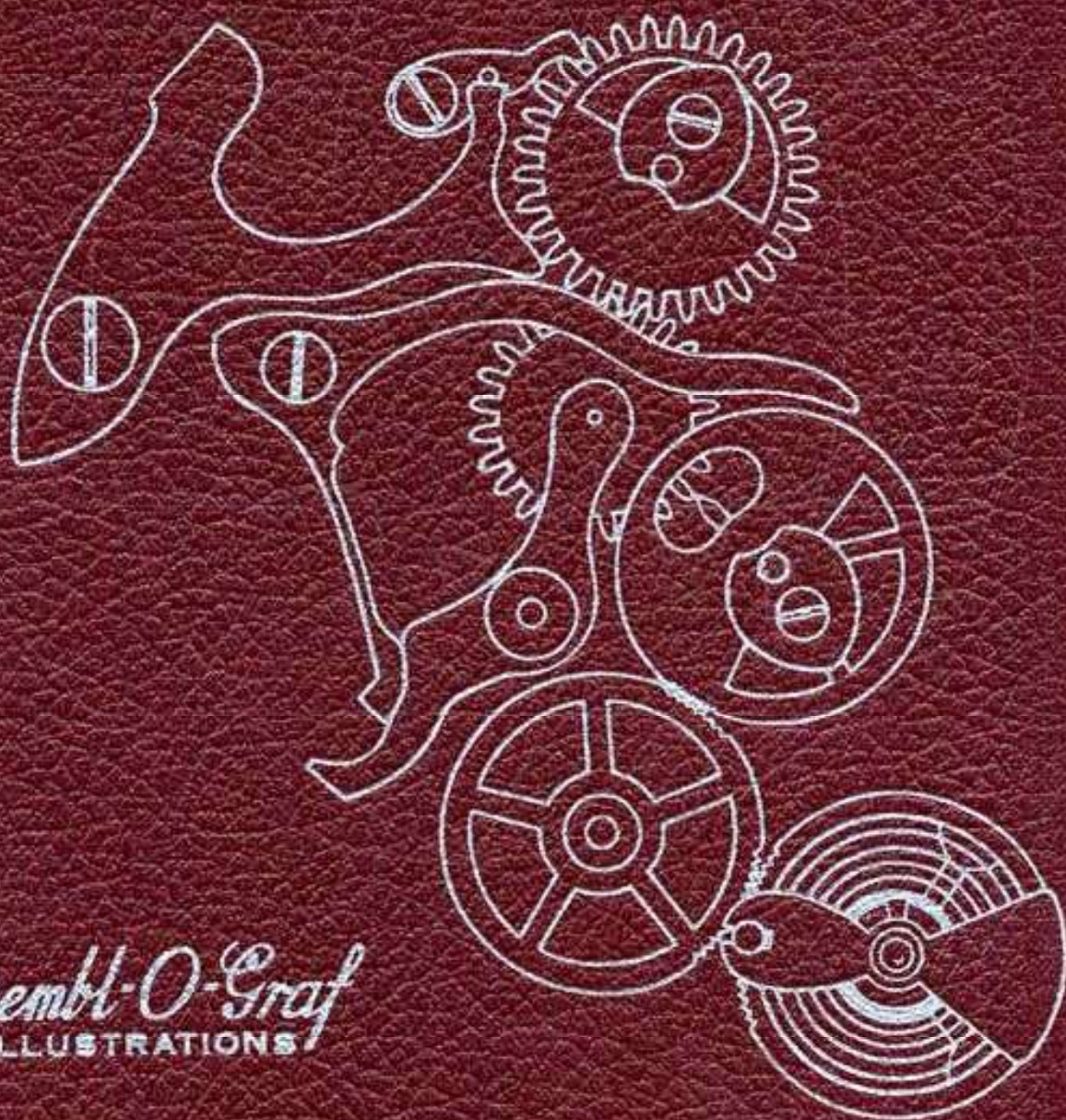

Essembl-O-Graf
ILLUSTRATIONS

IDENTIFICATION OF CHRONOGRAPH

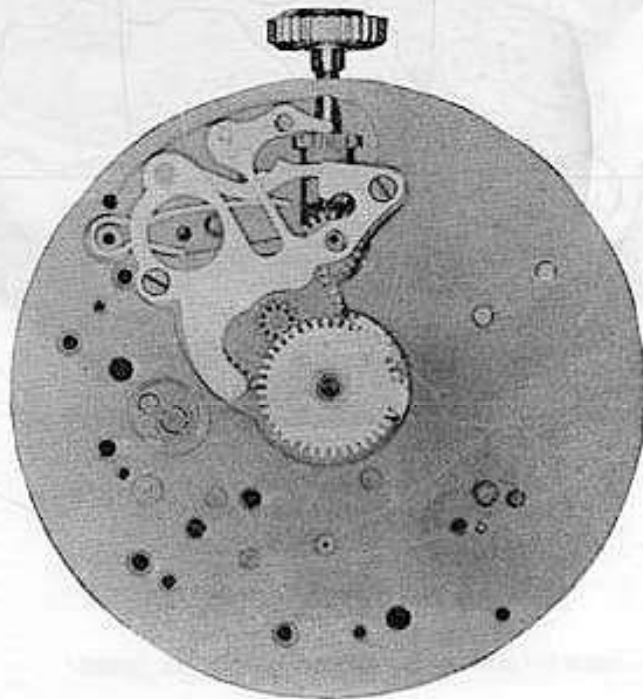

13 3/4 L



LANDERON

CAL. 48



ESEMBL-O-GRAF

THE WORLD'S FIRST FULLY
ILLUSTRATED TEXT BOOK
ON
CHRONOGRAPH REPAIRING
AND ADJUSTING

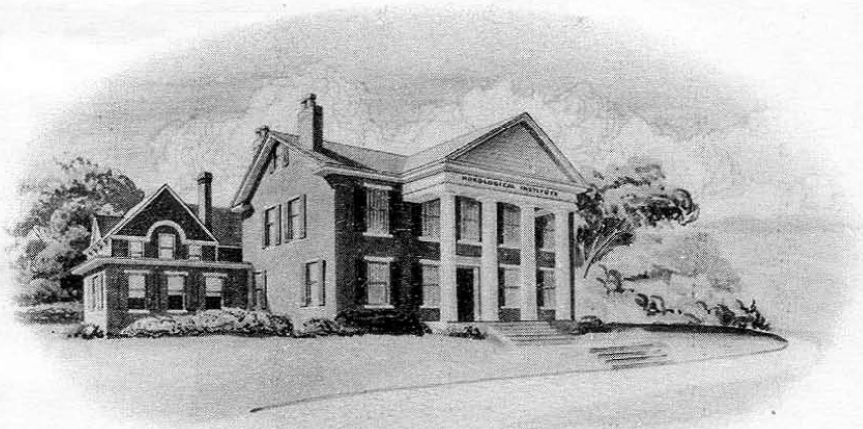

BY
William O. Smith, Sr.
PRESIDENT AND TECHNICAL DIRECTOR
AND
William O. Smith, Jr.
CHIEF ENGINEER, RESEARCH LABORATORIES

WESTERN PENNSYLVANIA HOROLOGICAL INSTITUTE, INC.
PITTSBURGH, PENNSYLVANIA

INSTRUCTIONS

For use of book

DISASSEMBLY OF THE CHRONOGRAPH MECHANISM:

1. Study the isometric drawing at top of page 1-A. The isometric drawing was made for the following purposes:
 - A. It helps to identify the part to be removed.
 - B. This drawing aids in pointing out certain locations on the part that are mentioned in the oiling procedure.
 - C. The text refers to certain points on the part. These points are shown in the isometric drawing. This should aid you in finding the exact location on the part that is described in the text.
 - D. It helps you to know the shape of the part in case a new part has to be made.
2. At the bottom of the page 1-A is a photograph of a chronograph. In this photograph is the same part painted in black. The part is in its exact location that this part occupies in the watch. Find this location in the watch.
3. Read the disassembly procedure and the hazards in disassembly on page 1 in this book.
4. Remove this part in the same procedure as described in the text.
5. A very important item in disassembling a chronograph is keeping the screws in order, much time will be lost in putting the chronograph together if screws are mixed up. This means you have to hunt for each screw, sometimes trying three or four screws before finding the correct one. It cannot be stressed too strongly that care should be taken so that screws are not mixed up. The system that we advise for beginners, is to replace each individual screw after each part is removed. This naturally eliminates the hazard of mixing up the screws and will save you much time in the end. Do this at least until you become so thoroughly familiar with the chronograph that you no longer feel it is necessary.
6. Continue to follow this procedure throughout the book and disassemble each part until the last part of the chronograph is removed.

ASSEMBLY OF THE CHRONOGRAPH MECHANISM:

7. When you are ready to assemble the chronograph mechanism, study the isometric drawing on the last part in this book. This drawing should aid you in identifying the part to be assembled.
8. At the bottom of this page is a photograph of a chronograph. In this photograph is the same part painted in black. The part is in its exact location that this part occupies in the watch.
9. Read the assembly procedure and the hazards in assembling for the last part in this book. (Continued on next page)

INSTRUCTIONS (Continued)

10. Replace the part in its exact location as shown in photograph, using the procedure as described in the text.

11. After you find the correct location for this part in the watch, read the oiling procedure for this part. The oiling procedure for this part is located underneath the isometric drawing. It is best to read the oiling procedure before you put each part in place as there are certain parts that must be oiled immediately as it may prove difficult to oil them later.

12. Replace the screw that holds this part in place. Of course, the screws should be kept in order as we advised above, but if the screws are not in order or the watch was received with screws mixed up, you will find a screw drawn for each part that requires a screw at the bottom of the text page.

13. After replacing this part, replace the next part, etc., until the last part is replaced, which will be part No. 1. Each part should be replaced using the same procedure as described in the text.

(Naturally, the assembly of the chronograph is exactly the reverse of the disassembly)

14. After disassembling and assembling the chronograph mechanism, start on page 1 and read the function of this part. After reading the function of this part, continue to read the function of each part throughout the book. Study each part, one at a time. This text should help you to understand more fully the purpose of each part in the chronograph mechanism.

15. Now put movement in its case with dial on, then replace hands.

16. Study the text on functional results in this book, and check the chronograph mechanism as described in this text.

NOMENCLATURE OF PART FOR CHRONOGRAPH MECHANISM







17. After you have become familiar with the chronograph mechanism, you can disassemble and assemble the chronograph by using the nomenclature of parts as a guide. This makes it possible for you to use a procedure without going through each page in the book.

18. ADJUSTMENT OF ECCENTRIC STUDS:

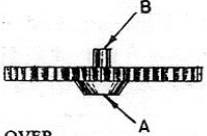
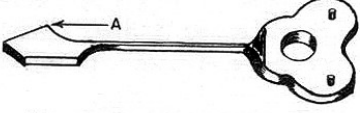
Read the text on adjustment of eccentric studs, this text should be read in reference to the eccentric stud picture. Now adjust each eccentric stud one at a time in the watch, as described in the text. Use the picture to show you the position of these studs.

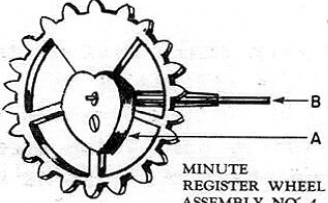
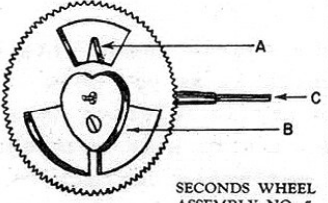
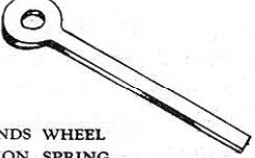
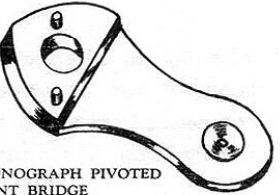
19. On each page in this book the part number and the page number are the same. This makes it convenient for the reader and eliminates any confusion.

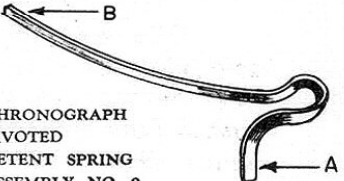
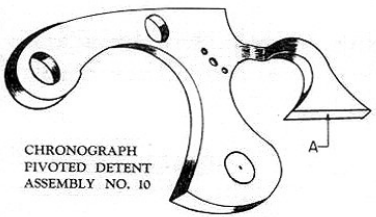
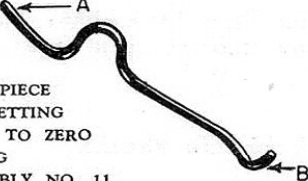
NOMENCLATURE OF PARTS

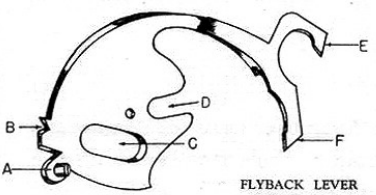
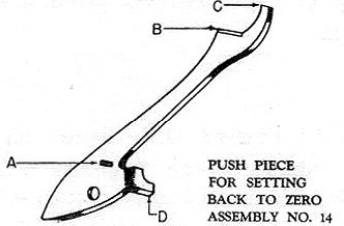
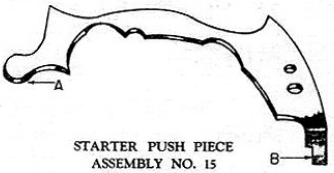
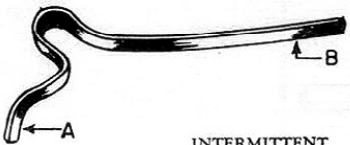
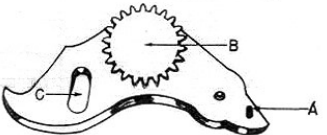
 <p style="text-align: center;">WHEEL OVER FOURTH WHEEL ASSEMBLY NO. 1</p>	 <p style="text-align: center;">MINUTE REGISTER PAWL ASSEMBLY NO. 2</p>	 <p style="text-align: center;">SECONDS WHEEL & MINUTE REGISTER WHEEL BRIDGE ASSEMBLY NO. 3</p>
 <p style="text-align: center;">MINUTE REGISTER WHEEL ASSEMBLY NO. 4</p>	 <p style="text-align: center;">SECONDS WHEEL ASSEMBLY NO. 5</p>	 <p style="text-align: center;">SECONDS WHEEL TENSION SPRING ASSEMBLY NO. 6</p>
 <p style="text-align: center;">CHRONOGRAPH PIVOTED DETENT BRIDGE ASSEMBLY NO. 7</p>	 <p style="text-align: center;">INTERMEDIARY WHEEL ASSEMBLY NO. 8</p>	 <p style="text-align: center;">CHRONOGRAPH PIVOTED DETENT SPRING ASSEMBLY NO. 9</p>
 <p style="text-align: center;">CHRONOGRAPH PIVOTED DETENT ASSEMBLY NO. 10</p>	 <p style="text-align: center;">PUSH PIECE FOR SETTING BACK TO ZERO SPRING ASSEMBLY NO. 11</p>	 <p style="text-align: center;">FLYBACK LEVER SPRING ASSEMBLY NO. 12</p>
 <p style="text-align: center;">FLYBACK LEVER ASSEMBLY NO. 13</p>	 <p style="text-align: center;">PUSH PIECE FOR SETTING BACK TO ZERO ASSEMBLY NO. 14</p>	 <p style="text-align: center;">STARTER PUSH PIECE ASSEMBLY NO. 15</p>
 <p style="text-align: center;">INTERMITTENT LEVER SPRING ASSEMBLY NO. 16</p>		 <p style="text-align: center;">INTERMITTENT LEVER & INT WHEEL ASSEMBLY ASSEMBLY NO. 17</p>

PART NO. 1

(A) DISASSEMBLY PROCEDURE OF WHEEL OVER FOURTH WHEEL:

The wheel over the fourth wheel, fits friction tight on post P-1 of fourth wheel pinion. This wheel should be removed with a sweep wheel remover, but can be removed with two small thin edge screwdrivers. The screwdrivers are placed opposite each other under hub of wheel. One screwdriver is turned clockwise while the other screwdriver is turned counter clockwise.

(The shape of post that this part fits on is shown at the bottom of page.)

(B) HAZARDS IN DISASSEMBLY OF WHEEL OVER FOURTH WHEEL:

The wheel over the fourth wheel fits on the very small post of the fourth wheel pinion, which is as you know very delicate and easily bent or broken. The main reason why we selected this part to be removed first is to avoid accidents such as a slip with a screwdriver and so on. If the sweep wheel remover is held perfectly upright in removing wheel, the hazards of bending fourth wheel post will be eliminated.

(C) ASSEMBLY PROCEDURE OF WHEEL OVER FOURTH WHEEL:

This wheel fits over fourth wheel post P-1. Wheel should be placed on post with the thin hub down. See Assembly 1 A. The long tapered hub on wheel will be up. See Assembly 1.B. The wheel over the fourth wheel should be pushed down until it is level with the intermediary wheel. A hollow flat face punch should be used to push wheel down.

(D) HAZARDS IN ASSEMBLING WHEEL OVER THE FOURTH WHEEL:

Use care in staking down this wheel so that you do not bend or break fourth wheel post. If movement is held level hazards of replacing this wheel will be eliminated.

(E) FUNCTION OF WHEEL OVER FOURTH WHEEL:

The function of this wheel is to transfer the power from the train of the watch to the chronograph mechanism. This wheel continues to turn as long as the watch is running.

REMARKS:

Mechanically we should regard this wheel as the intermediate chronograph wheel, as it is the main wheel which transfers the power from movement train to the chronograph mechanism. The Swiss term for this part is wheel over fourth wheel and we will use this term to describe this wheel in this text.

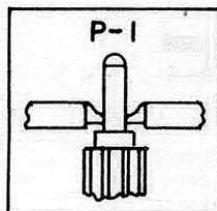

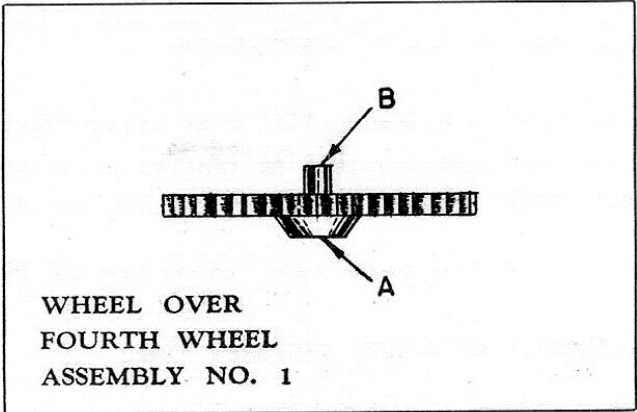

OILING

THE WHEEL OVER FOURTH WHEEL SHOULD NOT BE OILED.

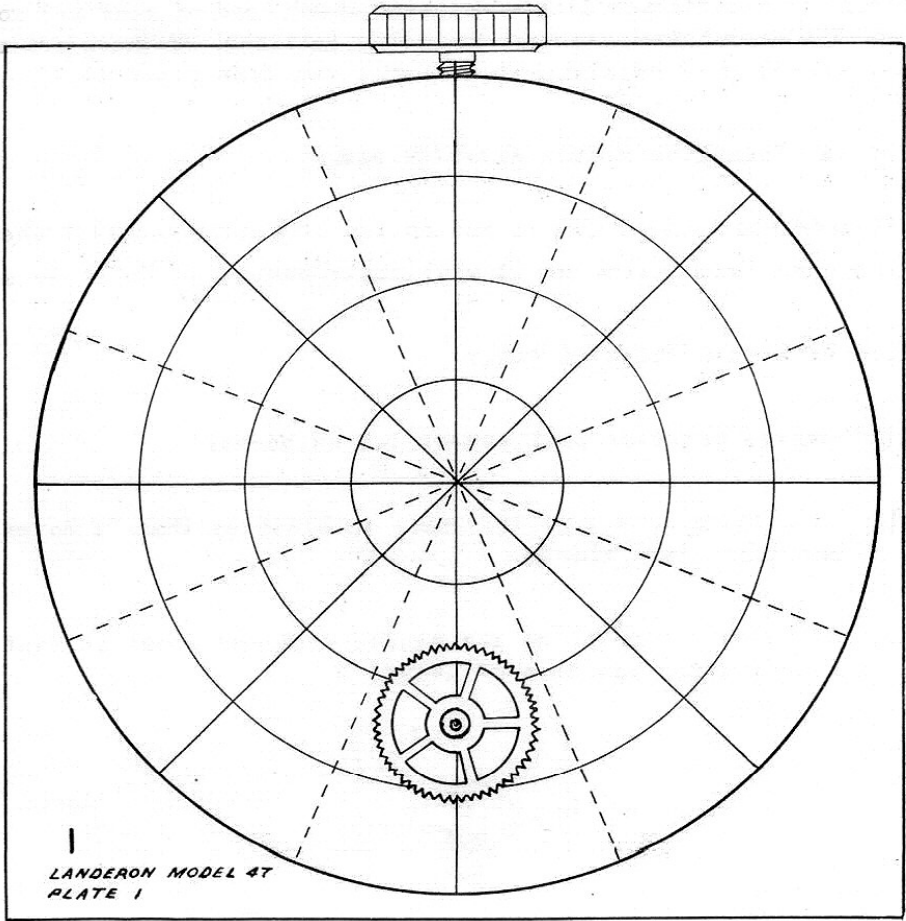

PART NO. 2

(A) DISASSEMBLY PROCEDURE OF MINUTE REGISTER PAWL:

This pawl is held in place by fillister screw FS-1 and steady pins. After screw is removed pawl can then be removed by sliding thin blade of screwdriver under corner of pawl taking great care not to scratch plates.

(The shape of screw for this part is shown at bottom of page)

(B) HAZARDS IN DISASSEMBLY OF MINUTE REGISTER PAWL:

The tension spring on this pawl is very thin and it can be ruined by a twist or a slight slip of the tool.

(C) ASSEMBLY PROCEDURE OF MINUTE REGISTER PAWL:

Lay pawl in position. Before pressing pawl down tight be sure the end of pawl is not on top of minute register wheel. This pawl is held in place by steady pins and fillister screw FS-1.

CAUTION - This pawl can cause the watch to stop by the pawl spring having too much tension. Pawl should have so little tension on minute register wheel that if you removed minute register wheel, end of pawl (A) would not move in. The end of pawl (A) must be highly polished. If there are any pits of rust around this location it will not function properly.

(D) HAZARDS IN ASSEMBLING MINUTE REGISTER PAWL:

Be sure end of pawl (A) is not on top of minute register wheel when pressing down into place, or it will cause damage to delicate spring.

(E) FUNCTION OF MINUTE REGISTER PAWL:

The minute register pawl serves two purposes.

1. It holds minute register wheel in place so that it moves exactly one tooth each minute.
2. It keeps a tension on the minute register wheel so that a bump cannot alter position of wheel.

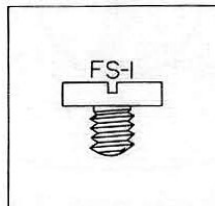

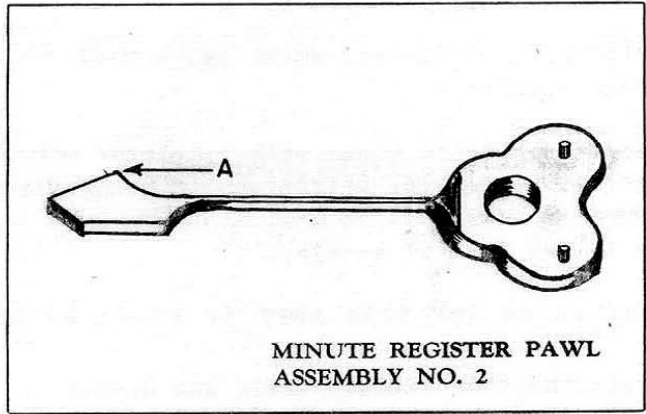

OILING

THE MINUTE REGISTER PAWL SHOULD NOT BE OILED.

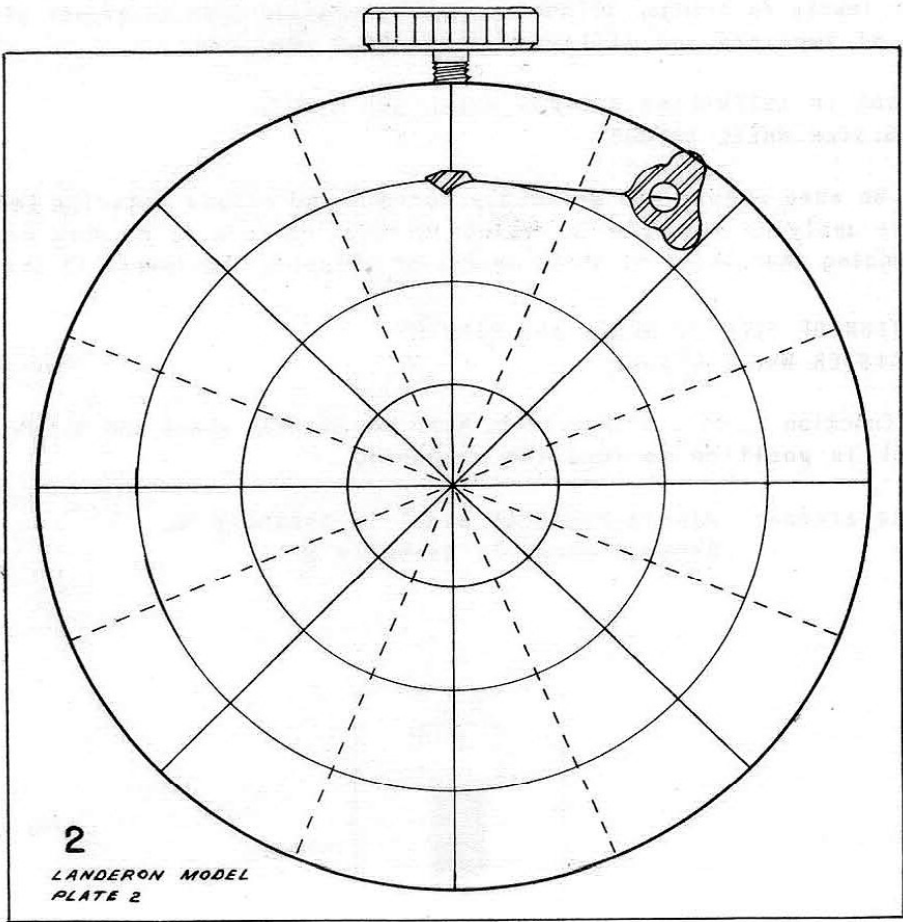

PART NO. 3

(A) DISASSEMBLY PROCEDURE OF SECONDS WHEEL AND MINUTE REGISTER WHEEL BRIDGE:

This bridge is held in place with fillister screw FS-2 and steady pins. After screw is removed, bridge should be carefully loosened from plate with a thin screwdriver. As soon as steady pins are free in plate, bridge may be lifted free of pivots.

(The shape of screw for this part is shown at bottom of page)

(B) HAZARDS IN DISASSEMBLY OF SECONDS WHEEL AND MINUTE REGISTER WHEEL BRIDGE:

When using a screwdriver to loosen the bridge, care should be taken to keep bridge level as any twisting may damage pivots on seconds wheel and minute register wheel or chip the jewels in bridge. The screwdriver should be carefully used to prevent marring of bridge or plate.

(C) ASSEMBLY PROCEDURE OF SECONDS WHEEL AND MINUTE REGISTER WHEEL BRIDGE:

This bridge is placed on plate with steady pins over proper holes in plate. Place seconds wheel and minute register wheel pivots so they will enter jewels in bridge. Bridge may now be pressed down to proper place with back of tweezers and fillister screw FS-2 replaced.

(D) HAZARDS IN ASSEMBLING SECONDS WHEEL AND MINUTE REGISTER WHEEL BRIDGE:

Be sure wheels are perfectly upright and pivots entering jewel holes before applying pressure to replace bridge. Failure to do this may result in bending the pivots of these wheels or chipping the jewels in the bridge.

(E) FUNCTION OF SECONDS WHEEL AND MINUTE REGISTER WHEEL BRIDGE:

Function of this bridge is to hold the seconds wheel and minute register wheel in position to function properly.

Reference: Minute register wheel is Assembly 4.
Seconds wheel is Assembly 5.

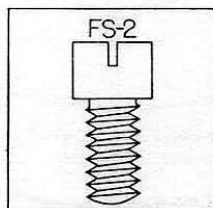

SECONDS WHEEL &
MINUTE REGISTER
WHEEL BRIDGE
ASSEMBLY NO. 3

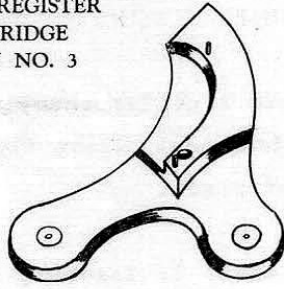

OILING

THE PIVOTS IN THE JEWELS IN THIS BRIDGE SHOULD BE OILED
AS YOU WOULD PROPERLY OIL A TRAIN PIVOT IN A WATCH.

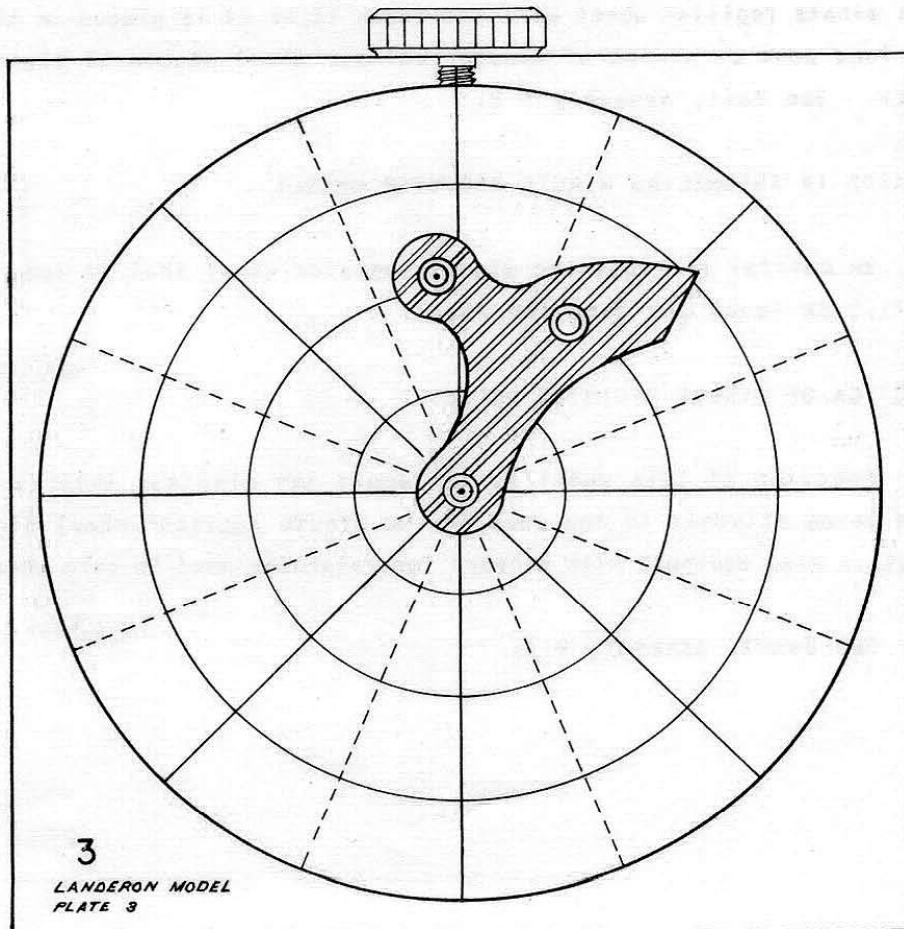

PART NO 4

(A) DISASSEMBLY PROCEDURE OF MINUTE REGISTER WHEEL:

Before removing minute register wheel, the flyback lever should be moved so that minute register wheel clears flyback lever. When this is done wheel can be lifted out of place.

Reference: Flyback lever is Assembly 13.

(B) HAZARDS IN DISASSEMBLY OF MINUTE REGISTER WHEEL:

Be careful in removing minute register wheel that it does not catch on flyback lever as it may bend the wheel.

(C) ASSEMBLY PROCEDURE OF MINUTE REGISTER WHEEL:

In replacing minute register wheel, place flyback lever in a position that minute register wheel will not touch it as it is placed in the watch. The long post on pinion of minute register wheel should be placed down in watch. See Post, Assembly 4 B.

(D) HAZARDS IN ASSEMBLING MINUTE REGISTER WHEEL:

Be careful in replacing minute register wheel that it does not catch on flyback lever and bend the wheel.

(E) FUNCTION OF MINUTE REGISTER WHEEL:

Function of this wheel is to record the minutes. This is done by a hand being attached to the post on the minute register wheel pinion. This wheel is also equipped with a heart for returning hand to zero when desired.

See Heart, Assembly 4 A.

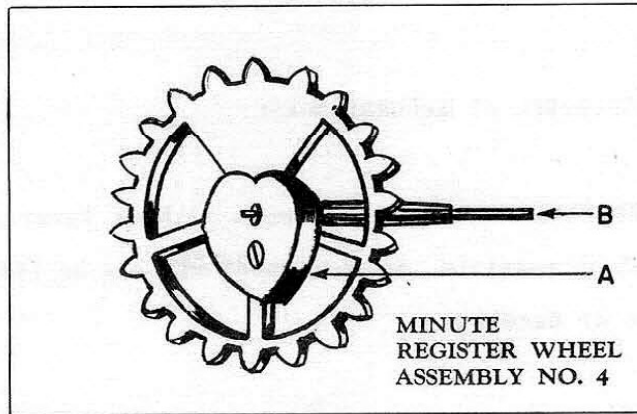

OILING

THE TOP PIVOT OF THE MINUTE REGISTER WHEEL SHOULD BE
OILED AFTER BRIDGE FOR THIS WHEEL IS PLACED IN WATCH.

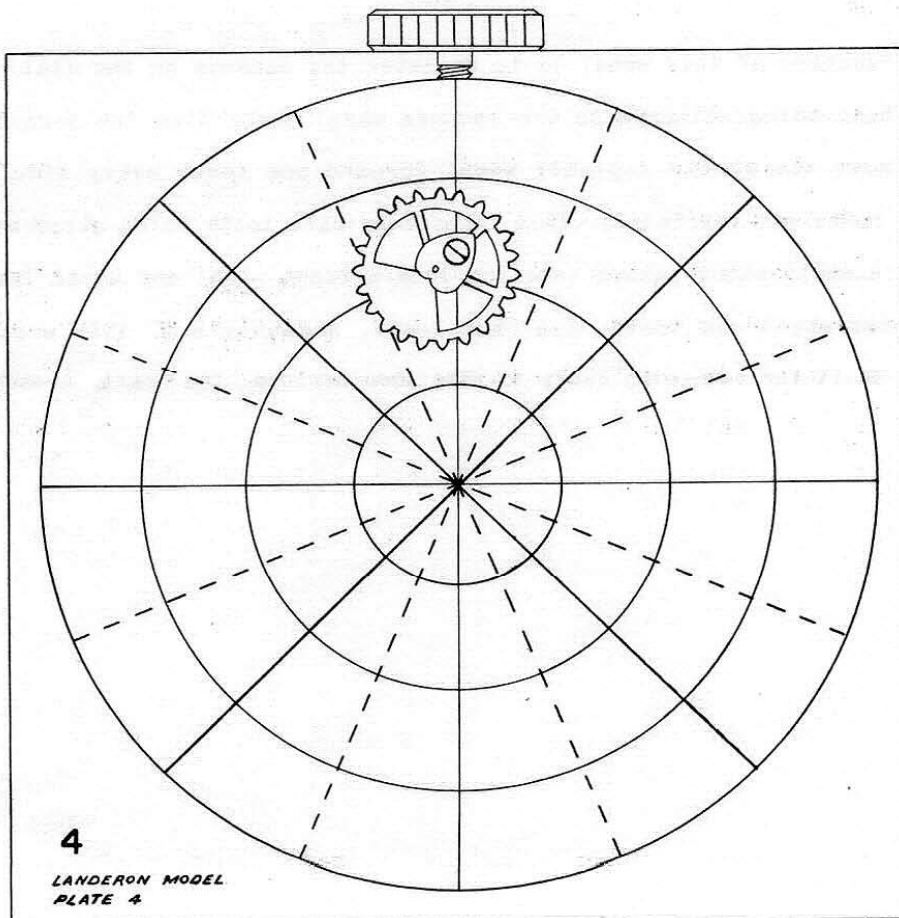

PART NO. 5

(A) DISASSEMBLY PROCEDURE OF SECONDS WHEEL:

Before removing seconds wheel, move flyback lever as far away from center of watch as possible. Seconds wheel may now be lifted out of plate without danger of bending.

(B) ASSEMBLY PROCEDURE OF SECONDS WHEEL:

Flyback lever should be moved as far as possible from center of watch before replacing seconds wheel. Seconds wheel should be placed on center hole with long post down. See Post, Assembly 5 C.

(C) FUNCTION OF SECONDS WHEEL:

Function of this wheel is to register the seconds on the dial by means of a hand being attached to the seconds wheel post. Also the seconds wheel must move the minute register wheel forward one tooth every time seconds wheel makes one revolution. This is done by dart tooth being attached to the seconds wheel which meshes into the Intermittent wheel and moves the minute register wheel one tooth. See Dart tooth, Assembly 5 A. This wheel has a heart on it for returning hands to zero when desired. See Heart, Assembly 5 B.

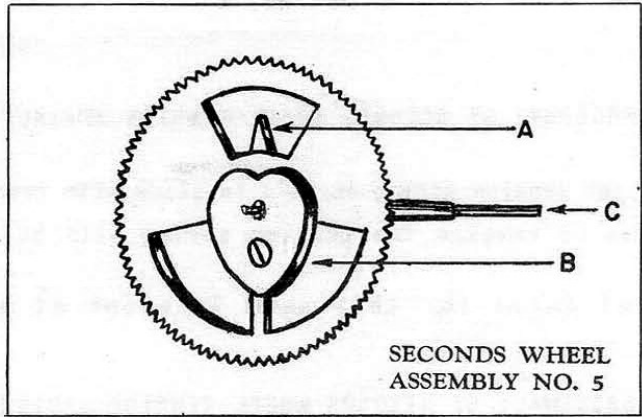

OILING

THE TOP PIVOT OF THE SECONDS WHEEL SHOULD BE OILED AFTER BRIDGE FOR THIS WHEEL IS PLACED IN WATCH.

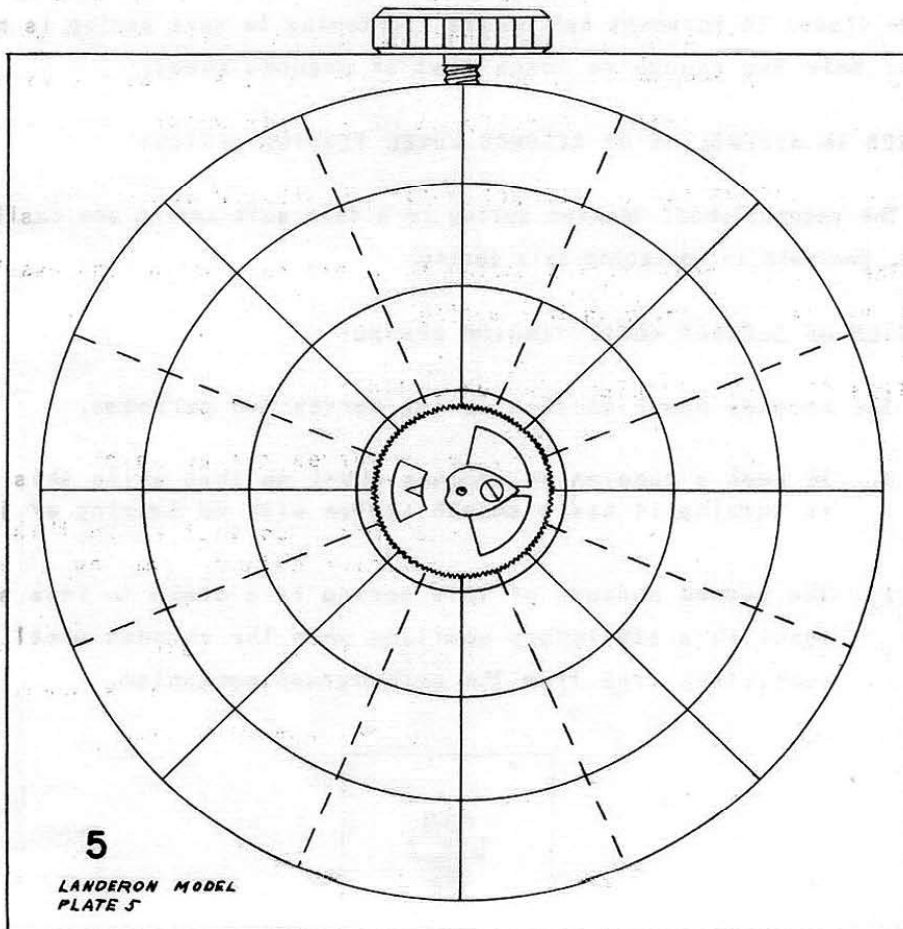

PART NO. 6

(A) DISASSEMBLY PROCEDURE OF SECONDS WHEEL TENSION SPRING:

Seconds wheel tension spring is held in place with fillister screw FS-3. When this screw is removed the tension spring will be free of plate.

(The shape of screw for this part is shown at bottom of page)

(B) HAZARDS IN DISASSEMBLY OF SECONDS WHEEL TENSION SPRING:

Be careful in removing this spring. It is a very thin soft spring and easily bent.

(C) ASSEMBLY PROCEDURE OF SECONDS WHEEL TENSION SPRING:

This tension spring is placed on watch with hole in spring over hole in plate for fillister screw FS-3. Be sure spring is right side up as there is a small dimple on end of spring that should be on top. Fillister screw, FS-3 may now be placed in movement but before tightening be sure spring is not over center hole far enough to touch post of seconds wheel.

(D) HAZARDS IN ASSEMBLING OF SECONDS WHEEL TENSION SPRING:

The seconds wheel tension spring is a thin soft spring and easily mutilated. Use care in replacing this spring.

(E) FUNCTION OF SECONDS WHEEL TENSION SPRING:

The seconds wheel tension spring serves two purposes.

1. To keep a tension on seconds wheel so that while this wheel is turning it has a smooth action with no jumping or jerking.
2. The second purpose of this spring is a brake to keep seconds wheel in a stationary position when the seconds wheel is completely free from the chronograph mechanism.

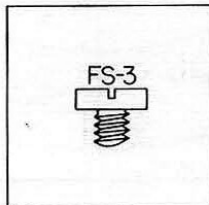

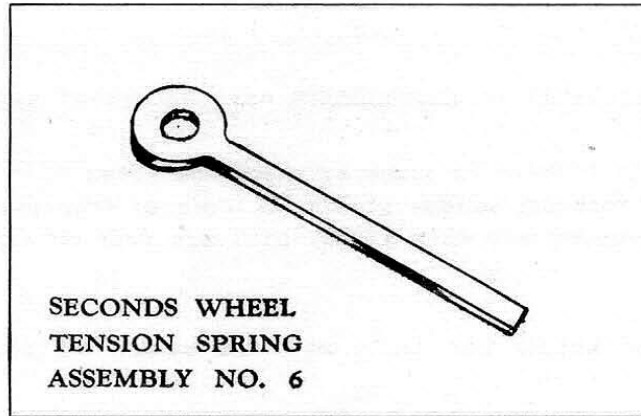

OILING

THE SECONDS WHEEL TENSION SPRING SHOULD NOT BE OILED.

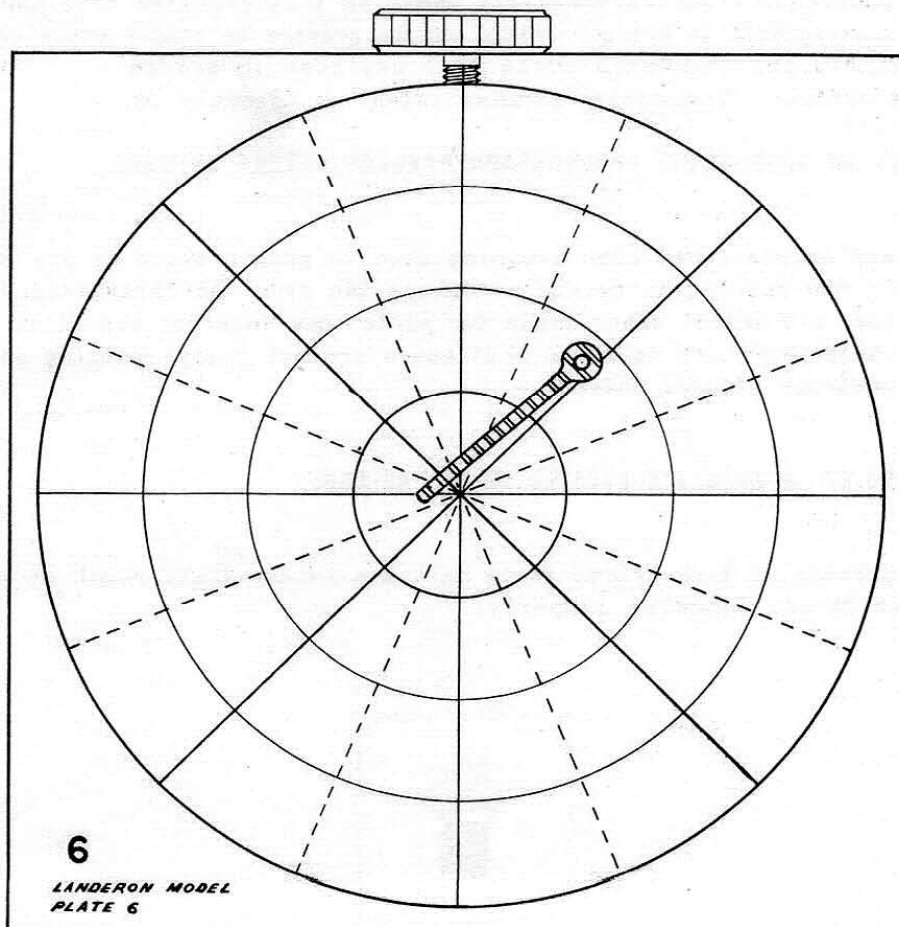

PART NO. 7

(A) DISASSEMBLY PROCEDURE OF CHRONOGRAPH PIVOTED DETENT BRIDGE;

This bridge is held in place by chamfered screw CS-1 and steady pins. After screw is removed, bridge should be loosened from pivoted detent by a thin bladed screwdriver. When steady pins are free of detent, bridge may be removed.

(The shape of screw for this part is shown at bottom of page)

(B) HAZARDS IN DISASSEMBLY OF CHRONOGRAPH PIVOTED DETENT BRIDGE:

When using a screwdriver to loosen the bridge from detent, care should be taken to keep bridge level as any twisting may damage pivot on intermediary wheel or burr the bushings in bridge or pivoted detent. The screwdriver should be carefully used to prevent marring of bridge or detent.

(C) ASSEMBLY PROCEDURE OF CHRONOGRAPH PIVOTED DETENT BRIDGE:

Place bridge on pivoted detent with steady pins over proper holes in pivoted detent. Place intermediary wheel so that pivot on this wheel will enter bushing hole in bridge. Bridge may be pressed to proper place with back of tweezers and chamfered screw CS-1 replaced in bridge.

Reference: Chronograph pivoted detent is Assembly 10.

(D) HAZARDS IN ASSEMBLING CHRONOGRAPH PIVOTED DETENT BRIDGE:

Keep bridge level when pressing down to proper place as any twisting may burr the bushing in bridge or damage the pivot on intermediary wheel. The bridge and detent where these two parts come together should be checked to see that there are no burrs that would prevent bridge setting properly on chronograph pivoted detent.

(E) FUNCTION OF CHRONOGRAPH PIVOTED DETENT BRIDGE:

Function of this bridge is to hold the intermediary wheel in position so that it can function properly.

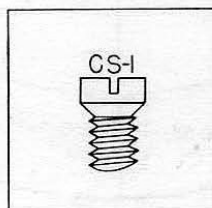

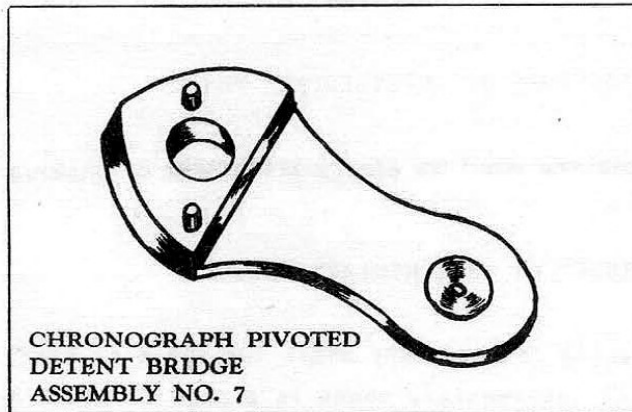

OILING

THE PIVOT IN BUSHING IN CHRONOGRAPH PIVOTED DETENT BRIDGE SHOULD BE OILED AS YOU WOULD PROPERLY OIL A TRAIN PIVOT IN A WATCH.

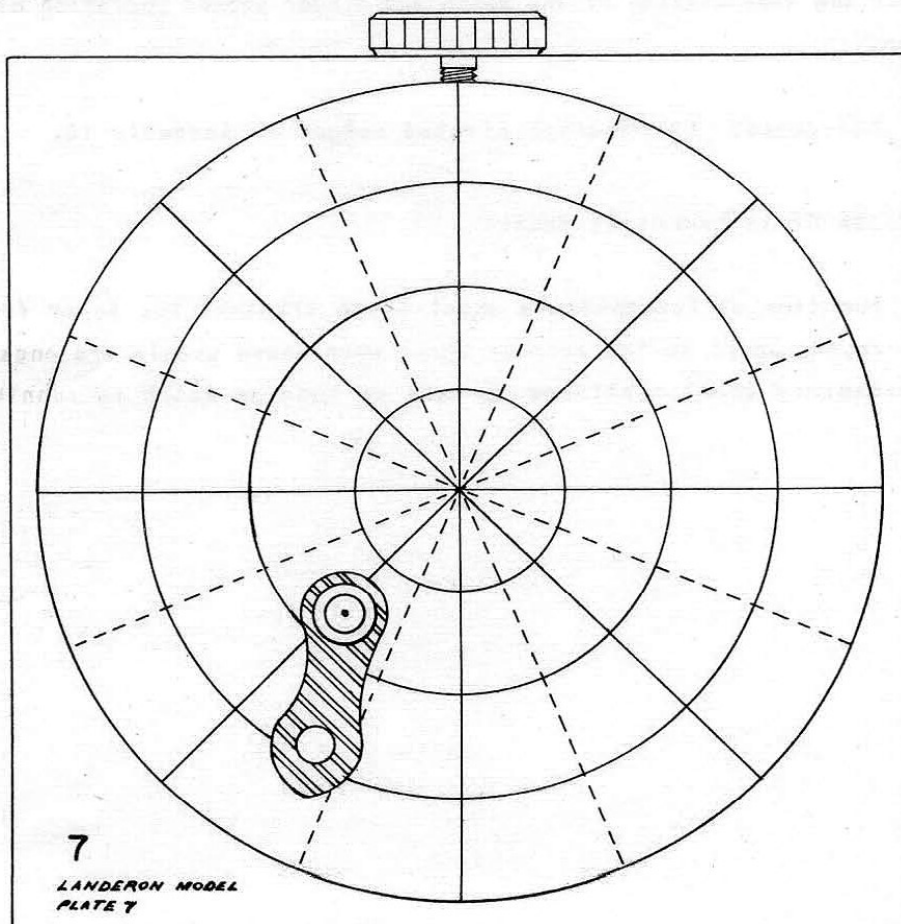

(A) DISASSEMBLY PROCEDURE OF INTERMEDIARY WHEEL:

The intermediary wheel is simply lifted out of bushing in pivoted detent.

(B) ASSEMBLY PROCEDURE OF INTERMEDIARY WHEEL:

When replacing intermediary wheel the end A of staff should be placed up. The pivot of intermediary wheel is placed in pivot hole in bushing of chronograph pivoted detent.

Reference: Chronograph pivoted detent is Assembly 10.

(C) HAZARDS IN ASSEMBLY OF INTERMEDIARY WHEEL:

Pivot hole in bushing of chronograph pivoted detent should be carefully examined before replacing intermediary wheel. Any imperfections here will affect the time keeping of the watch and hinder proper operation of chronograph.

Reference: Chronograph pivoted detent is Assembly 10.

(D) FUNCTION OF INTERMEDIARY WHEEL:

Function of intermediary wheel is to transmit the power from wheel over fourth wheel to the seconds wheel when these wheels are engaged. The intermediary wheel continues to turn as long as watch is running.

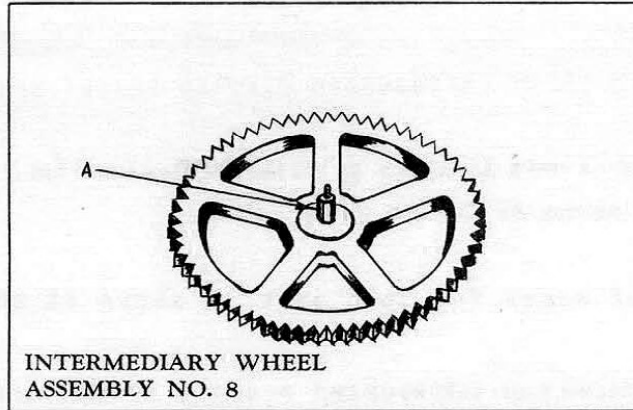

OILING

THE BOTTOM PIVOT OF INTERMEDIARY WHEEL SHOULD BE OILED BEFORE PLACING PIVOT IN PLACE IN CHRONOGRAPH PIVOTED DETENT. THE TOP PIVOT SHOULD BE OILED AFTER BRIDGE FOR THIS WHEEL IS PLACED IN WATCH.

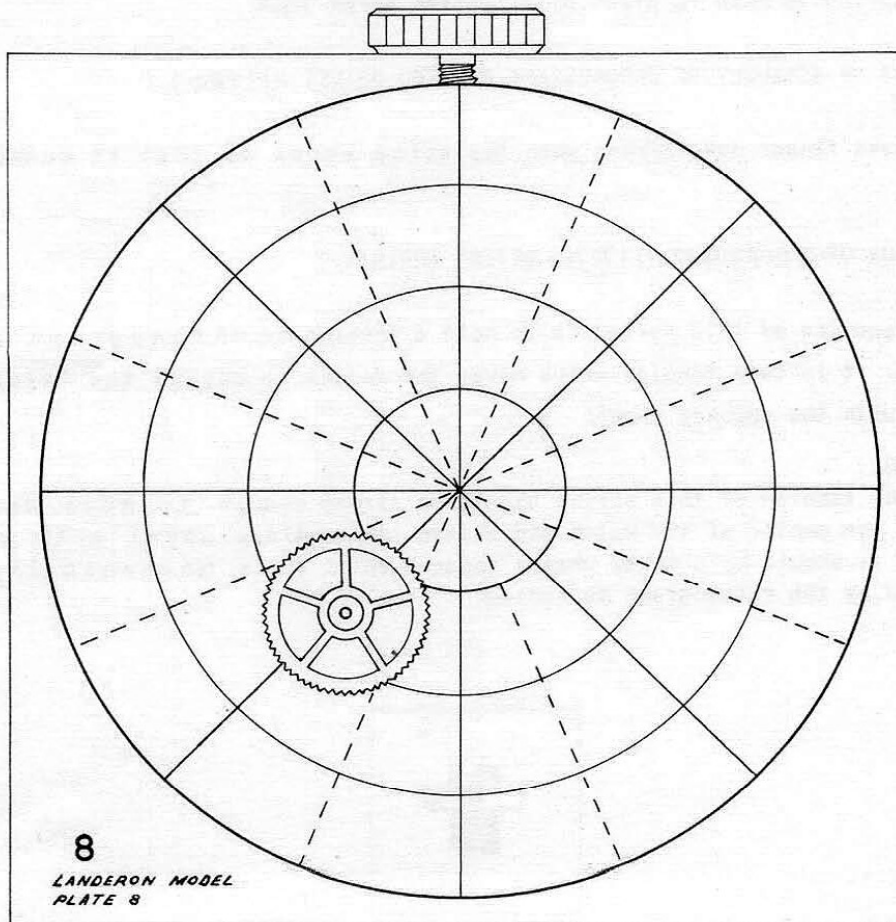

PART NO. 9

(A) DISASSEMBLY PROCEDURE OF CHRONOGRAPH PIVOTED DETENT SPRING:

This spring is held in place by fillister screw FS-4. After this screw is removed, spring may be lifted from plate.

(The shape of screw for this part is shown at bottom of page)

(B) HAZARDS IN DISASSEMBLY OF CHRONOGRAPH PIVOTED DETENT SPRING:

Hold finger over spring when removing screw so that spring does not shoot away.

(C) ASSEMBLY PROCEDURE OF CHRONOGRAPH PIVOTED DETENT SPRING:

This is a small wire spring with a loop in it which fits over screw hole in plate. End of spring (A) is bent and fits down in hole H-1 in plate. The opposite end of spring (B) is placed so that it touches pivoted detent. This spring is held in place by fillister screw FS-4

(D) HAZARDS IN ASSEMBLY OF CHRONOGRAPH PIVOTED DETENT SPRING :

Hold finger over spring when replacing screw so that it cannot shoot away.

(E) FUNCTION OF CHRONOGRAPH PIVOTED DETENT SPRING:

Function of this spring is to hold a tension on chronograph pivoted detent. It is this tension which moves the detent to engage the intermediary wheel with the seconds wheel.

(F) REMARKS:

The tension of this spring should be strong enough to move detent in toward the center of the watch and engage intermediary wheel with seconds wheel. It should hold these wheels engaged until it is mechanically disengaged by the chronograph mechanism.

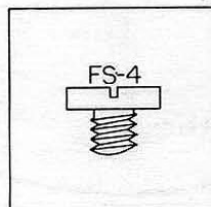

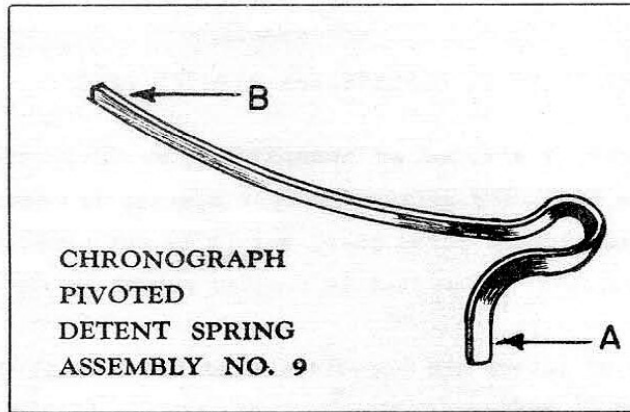

OILING

THE CHRONOGRAPH PIVOTED DETENT SPRING SHOULD NOT BE OILED.

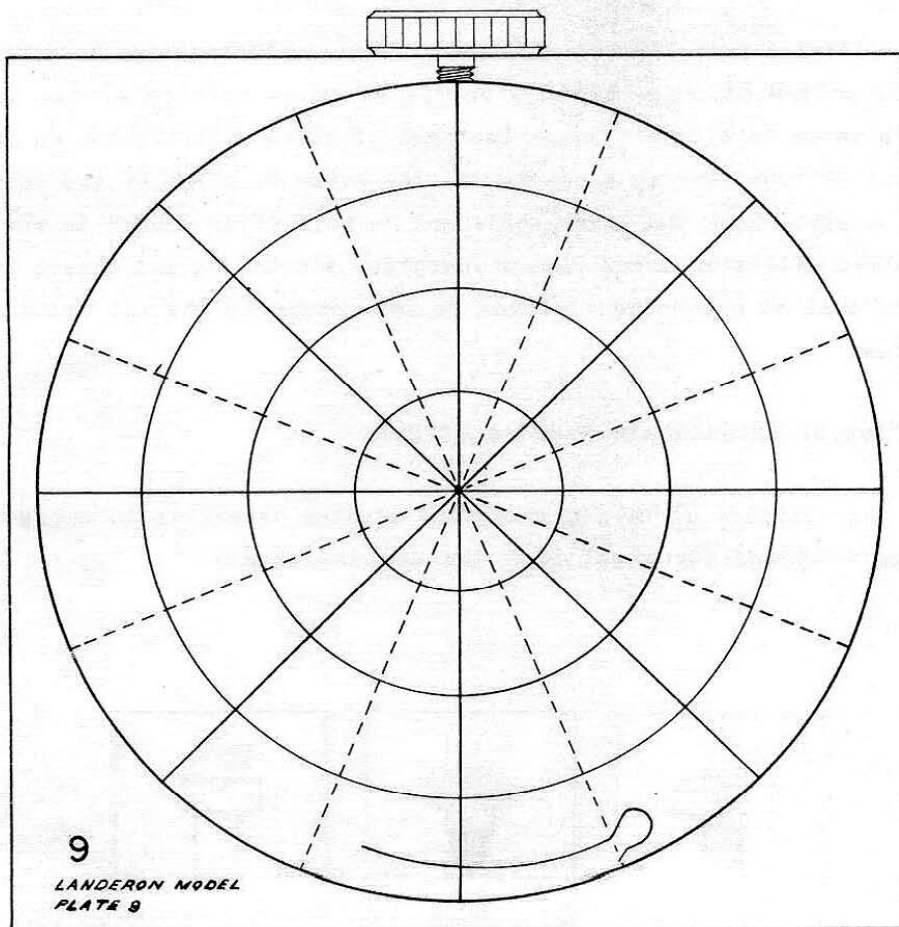

PART NO. 10

(A) DISASSEMBLY PROCEDURE OF CHRONOGRAPH PIVOTED DETENT:

This detent is pivoted on eccentric stud ES-1 and held in place by fillister screw FS-5. The point of detent nearest to center of watch slides under head of shouldered screw SS-1, but it is not necessary to remove this screw. After fillister screw FS-5 is removed detent may be lifted from plate.

(The shape of screws and eccentric stud for this part is shown at the bottom of page.)

(B) ASSEMBLY PROCEDURE OF CHRONOGRAPH PIVOTED DETENT:

Lay detent in proper position on plate with hole in detent over eccentric stud ES-1 as detent pivots on this stud. The point of detent nearest center of watch should slide under shouldered screw SS-1. The detent is held in place by fillister screw FS-5.

(C) HAZARDS OF ASSEMBLING CHRONOGRAPH PIVOTED DETENT:

Fillister screw FS-5 is prevented from tightening down on detent lever by the bottom of screw hitting bottom of screw hole in plate. Naturally if the screw is slightly short the head of screw will tighten on detent and prevent it from working properly. If the screw is slightly too long or dirt gets in screw hole the lever would not be held close enough to plate. After replacing fillister screw FS-5 chronograph pivoted detent should be checked to see that it has enough freedom to work properly and yet not have excess freedom.

(D) FUNCTION OF CHRONOGRAPH PIVOTED DETENT:

The function of this chronograph pivoted detent is to engage and disengage intermediary wheel with the seconds wheel.

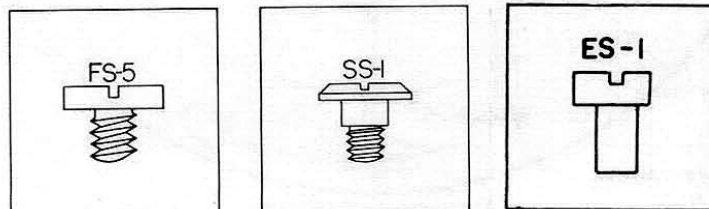

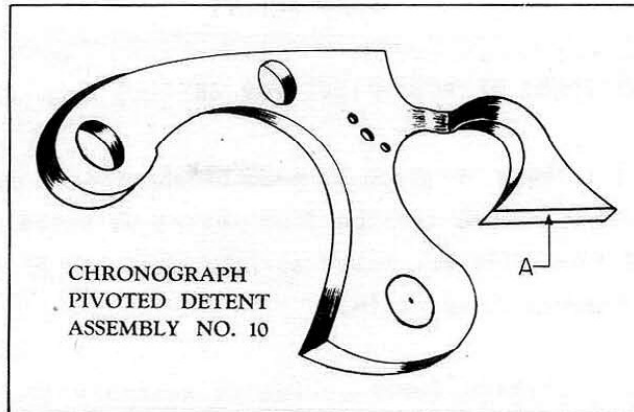

OILING

THE ECCENTRIC STUD ES-1 THAT CHRONOGRAPH PIVOTED DETENT PIVOTS ON SHOULD BE SLIGHTLY MOISTENED WITH OIL. THE PART OF CHRONOGRAPH PIVOTED DETENT "A" THAT CONTACTS ECCENTRIC STUD ES-3 ON FLYBACK LEVER SHOULD BE SLIGHTLY MOISTENED WITH OIL

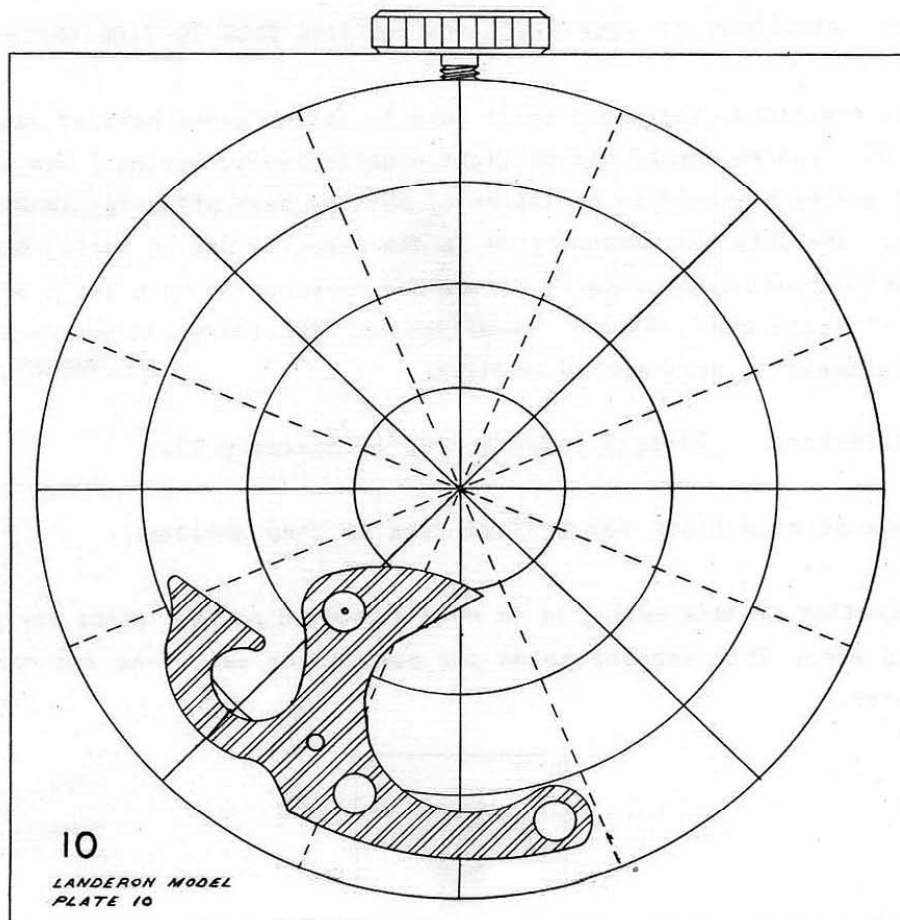

PART NO. 11

(A) DISASSEMBLY PROCEDURE OF PUSH PIECE FOR SETTING BACK TO ZERO SPRING:

This spring is held in place by head of shouldered screw SS-2. Loosen screw slightly then remove tension from spring by using tweezers to lift end of spring B from flyback lever spring. When end of Spring B is free spring may be removed from plate.

Reference: Flyback lever spring is Assembly 12.

(The shape of screw for this part is shown at bottom of page)

(B) HAZARDS OF DISASSEMBLY OF PUSH PIECE FOR SETTING BACK TO ZERO SPRING:

Do not remove screw before removing tension on spring as screw or spring may shoot away and be lost.

(C) ASSEMBLY PROCEDURE OF PUSH PIECE FOR SETTING BACK TO ZERO SPRING:

To replace spring place small loop in spring under head of shouldered screw SS-2 (screw should not be tight when replacing spring.) The straight end of spring A should be on inside of post on push piece for setting back to zero. See this post Assembly 14 A. The opposite end of spring B will be free and extend beyond edge of plate. Use tweezers to move end B of spring until it hooks over flyback lever spring. Shouldered screw SS-2 may be now tightened to hold spring in place.

Reference: Flyback lever spring is Assembly 12.

(D) FUNCTION OF PUSH PIECE FOR SETTING BACK TO ZERO SPRING:

Function of this spring is to hold a tension on push piece for setting back to zero. This tension holds the push piece away from the center of the watch.

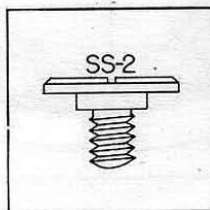

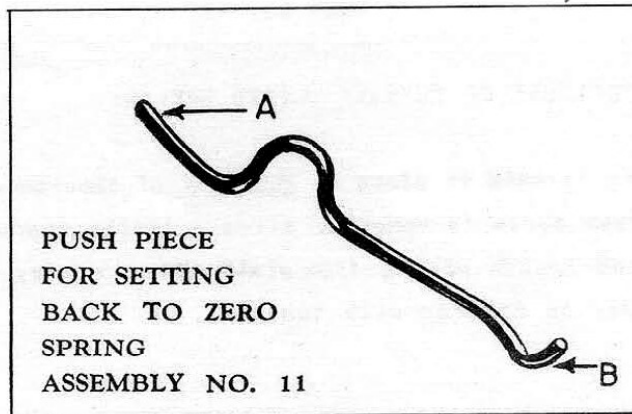

OILING

PUSH PIECE FOR SETTING BACK TO ZERO SPRING SHOULD NOT
BE OILED.

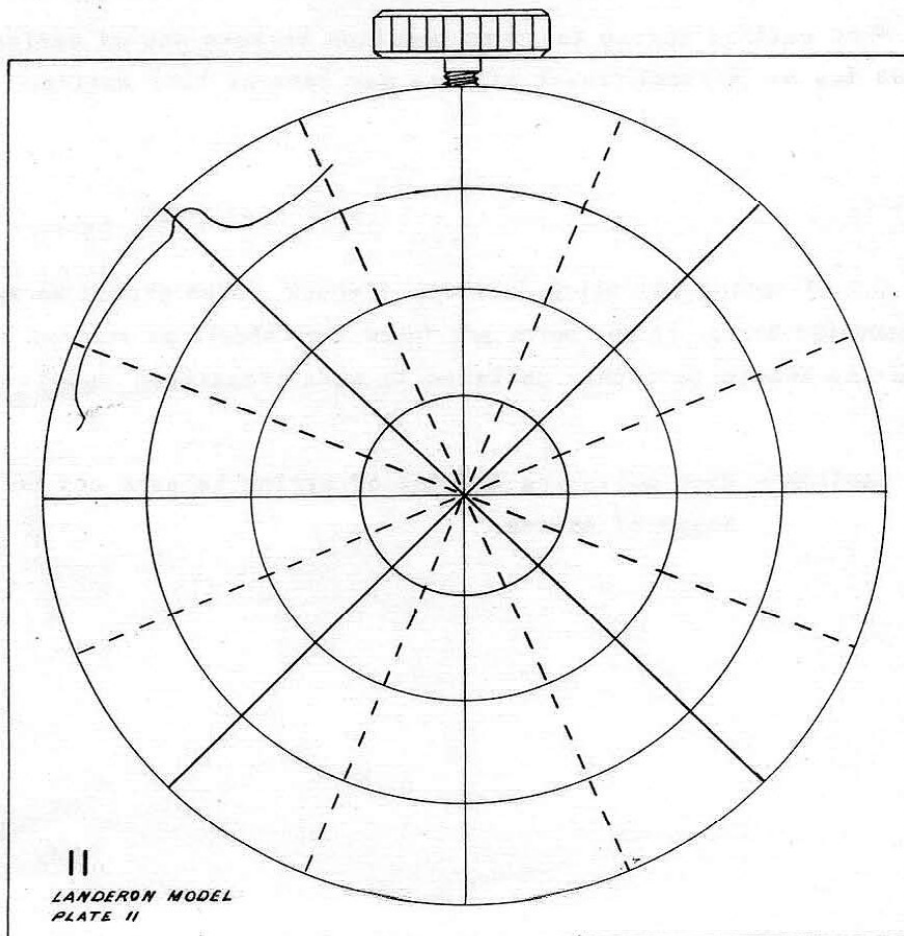

PART NO. 12

(A) DISASSEMBLY PROCEDURE OF FLYBACK LEVER SPRING:

This spring is held in place by shoulder of shouldered screw SS-2 and steady pins. When screw is removed, slide a finely sharpened screwdriver under spring and loosen spring from plate. When steady pins are free of plate spring may be removed with tweezers.

(B) ASSEMBLY PROCEDURE OF FLYBACK LEVER SPRING:

To replace spring, move flyback lever as far as possible toward center of the watch. In replacing spring, place steady pins over proper holes in plate, then press spring to proper place with back of tweezers. Shouldered screw SS-2 may now be replaced.

(C) HAZARDS IN ASSEMBLING OF FLYBACK LEVER SPRING:

When putting spring to exact position be sure end of spring (A) is not on top of flyback lever or this may bend or burr spring.

(D) REMARKS:

End of spring (A) which contacts flyback lever should be carefully examined for burrs. If any burrs are found they should be removed. This end of spring should be highly polished to work properly.

CAUTION - When polishing the end of spring be sure not to change shape of spring.

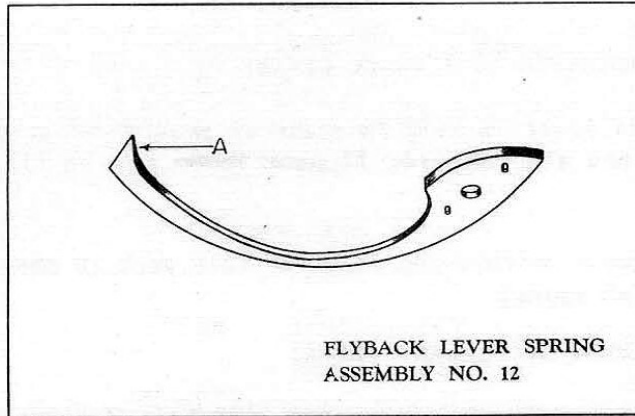

OILING

THE END OF FLYBACK LEVER SPRING "A" THAT CONTACTS
FLYBACK LEVER SHOULD BE SLIGHTLY MOISTENED WITH OIL.

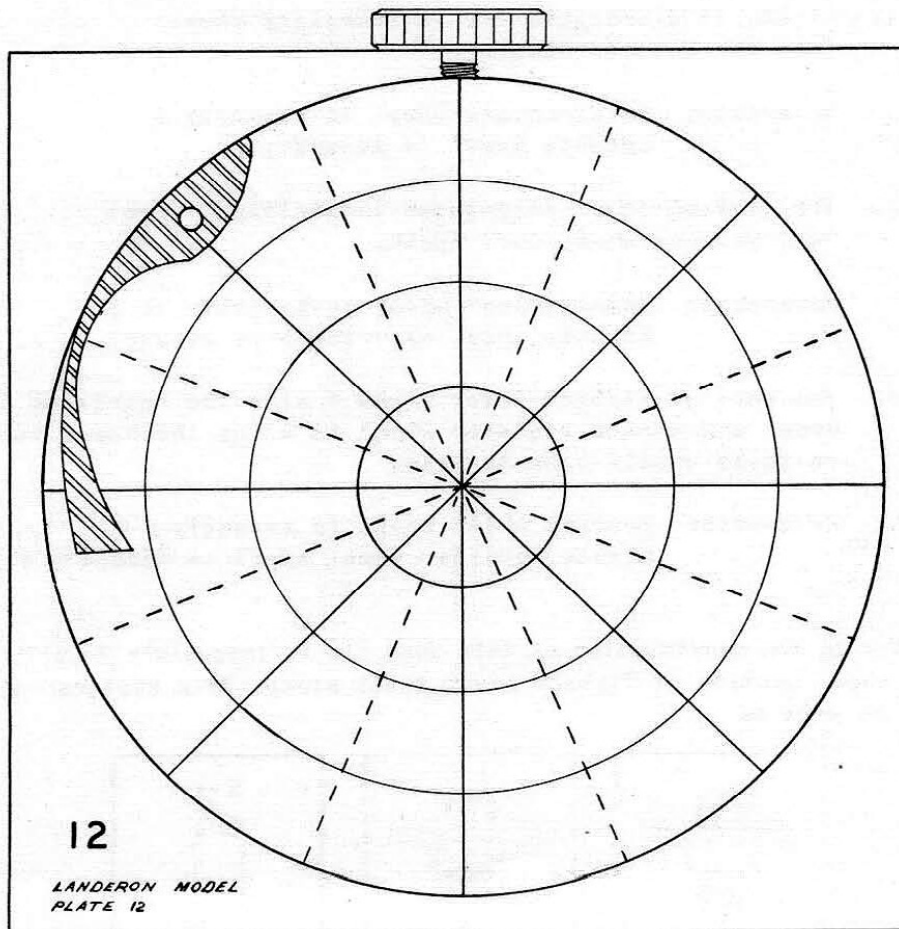

PART NO. 13.

(A) DISASSEMBLY PROCEDURE OF FLYBACK LEVER:

The flyback lever is held in place by shouldered screws SS-3 and SS-4. When these screws are removed, flyback lever may be lifted from stud S-1 in plate.

(The shape of screws and stud for this part is shown at the bottom of page.)

(B) ASSEMBLY PROCEDURE OF FLYBACK LEVER:

This lever is placed in movement with hole in lever over stud S-1 in plate, as lever pivots on this stud. The U shaped slot D of flyback lever should fit over end of starter push piece. The flyback lever is held in place by shouldered screw SS-3 which fits in slot C of flyback lever. Another shouldered screw SS-4 is placed so that head of screw is partly over flyback lever and partly over starter push piece. The flyback lever should work freely under the heads of these screws.

(C) FUNCTION OF FLYBACK LEVER:

Function of flyback lever is to do three things:

1. First, it disengages the intermediary wheel from the seconds wheel.

Reference: Intermediary wheel is Assembly 8.
Seconds wheel is Assembly 5.

2. The flyback lever disengages intermittent wheel from seconds wheel dart tooth.

Reference: Intermittent wheel is Assembly 17 B.
Seconds wheel dart tooth is Assembly 5 A.

3. The ends of flyback lever E and F hits the hearts on seconds wheel and minute register wheel to bring the hands connected to these wheels back to zero.

Reference: Seconds wheel heart is Assembly 5 B.
Minute register wheel heart is Assembly 4 A.

Due to the construction of this book, it is impossible to print at this place, how function of flyback lever takes place. This explanation will be found on page 18

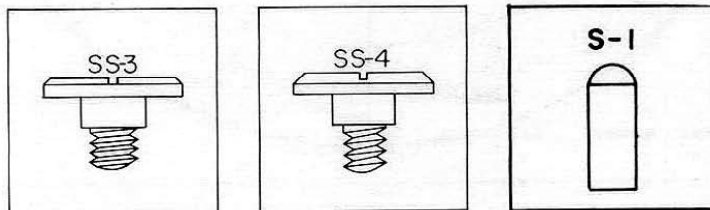

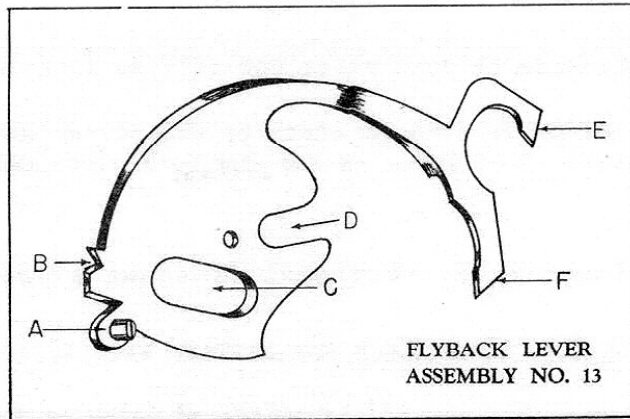

OILING

THESE PARTS OF FLYBACK LEVER SHOULD BE SLIGHTLY MOISTENED WITH OIL.

1. THE STUD S-1 THAT FLYBACK LEVER PIVOTS ON.
2. WHERE FLYBACK LEVER CONTACTS END 'C' OF PUSH PIECE FOR SETTING BACK TO ZERO.
3. WHERE FLYBACK LEVER CONTACTS STUD ES-4 ON INTERMITTENT LEVER.
4. THE U SHAPED SLOT 'D' IN FLYBACK LEVER THAT CONTACTS STARTER PUSH PIECE.

REFERENCE: PUSH PIECE FOR SETTING BACK TO ZERO IS ASSEMBLY 14. STARTER PUSH PIECE IS ASSEMBLY 15.

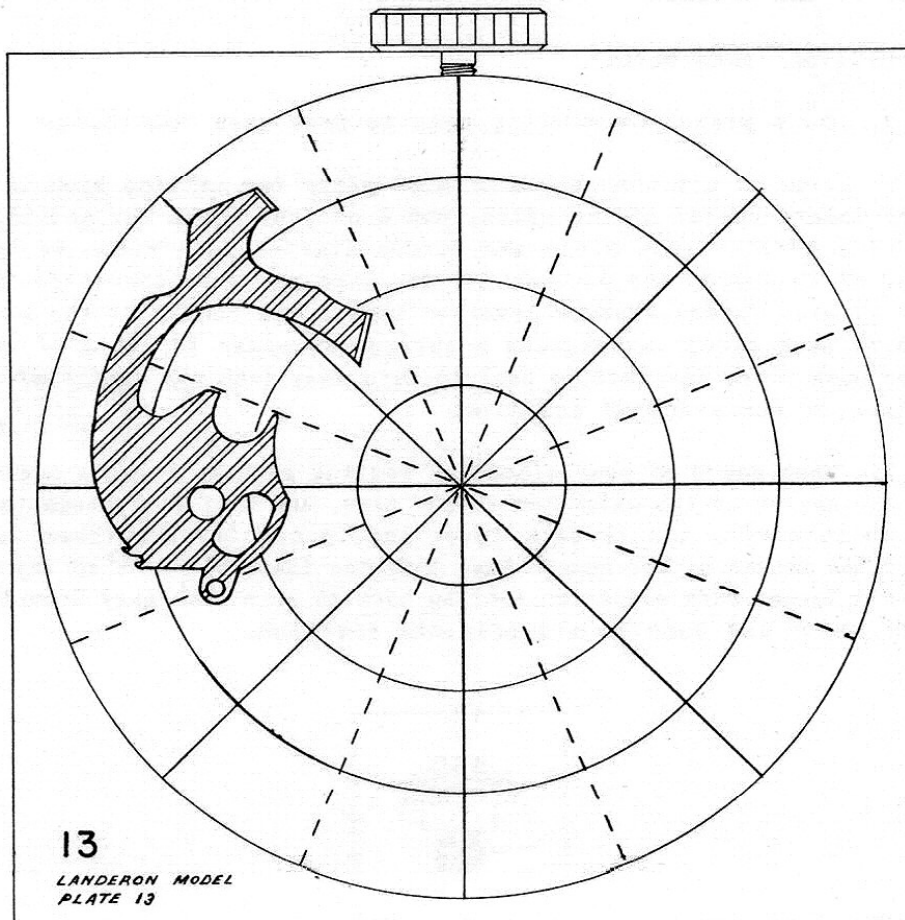

PART NO. 14

(A) DISASSEMBLY PROCEDURE OF PUSH PIECE FOR SETTING BACK TO ZERO:

This push piece is held in place by shouldered screw SS-5, a left thread screw. After this screw is removed push piece may be lifted from plate.

(The shape of screw for this part is shown at bottom of page)

(B) ASSEMBLY PROCEDURE OF PUSH PIECE FOR SETTING BACK TO ZERO:

Move starter push piece toward center of watch as far as it will go, then place push piece for setting back to zero in proper position on plate. This push piece is held in place by a left thread shouldered screw SS-5. Push piece must work freely under head of screw. The left thread screw can be identified by the two lines running parallel to screw slot in head of screw.

Reference: Starter push piece is Assembly 15.

(C) FUNCTION OF PUSH PIECE FOR SETTING BACK TO ZERO:

This piece when pushed in must throw the flyback lever in toward the center of the watch.

(D) HOW FUNCTION TAKES PLACE:

1. Push piece for setting back to zero does two things:

First of all when end D of push piece for setting back to zero is pushed toward center of the watch, end B of push piece for setting back to zero hits starter push piece and forces starter push piece in toward the center of the watch and because starter push piece is connected to flyback lever it also forces flyback lever in toward the center of the watch. When end D of push piece is released a spring connected to pin A of push piece forces push piece for setting back to zero away from the center of the watch and back to its original position.

2. When end D of push piece for setting back to zero is pushed in toward the center of the watch the second time, end C of push piece for setting back to zero hits the flyback lever and forces flyback lever further in toward the center of the watch. When this has taken place, a spring connected to pin A forces push piece for setting back to zero back away from the center of the watch and back to its original position.

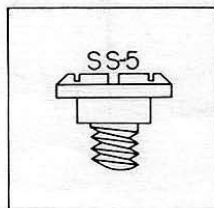

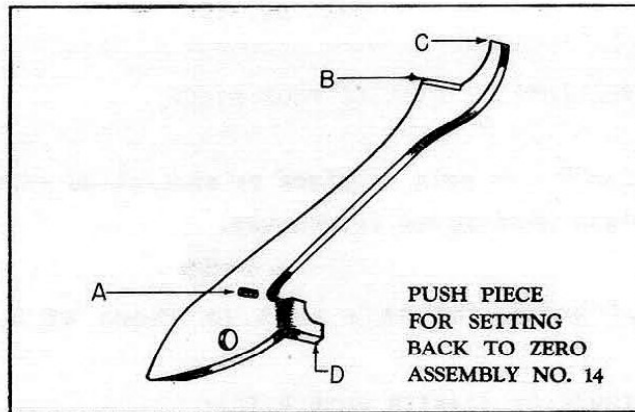

OILING

THE SHOULDER SCREW SS-5 THAT PUSH FOR SETTING BACK TO ZERO PIVOTS ON SHOULD BE SLIGHTLY MOISTENED WITH OIL. END OF PUSH PIECE FOR SETTING BACK TO ZERO "B" THAT CONTACTS STARTER PUSH PIECE SHOULD BE SLIGHTLY MOISTENED WITH OIL.

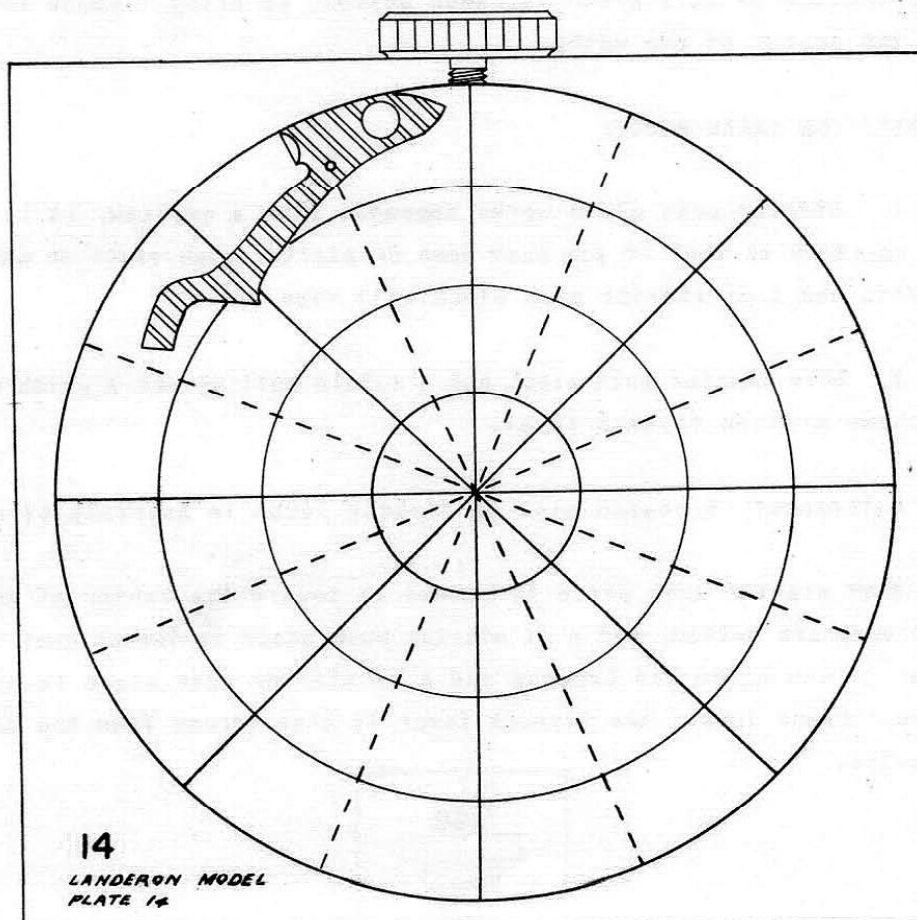

PART NO. 15

(A) DISASSEMBLY PROCEDURE OF STARTER PUSH PIECE:

This push piece is held in place by shouldered screw SS-6 and may be lifted from plate when screw is removed.

(The shape of screw for this part is shown at bottom of page)

(B) ASSEMBLY PROCEDURE OF STARTER PUSH PIECE:

Lay push piece in proper position on plate. A shouldered screw SS-6 is used to hold push piece in position as push piece pivots under head of this screw. After replacing screw, check push piece to see that it does move freely under screw head.

(C) FUNCTION OF STARTER PUSH PIECE:

Function of this piece is, when pushed, to bring flyback lever away from the center of the watch.

(D) HOW FUNCTION TAKES PLACE:

1. Starter push piece works somewhat like a see-saw, it is pivoted in a position so that if you push down on starter push piece on end B, the opposite end A of starter push piece will rise up.

2. This starter push piece has a little ball on end A which works in a U shape slot on flyback lever.

Reference: U shaped slot on flyback lever is Assembly 13 D.

When starter push piece is pushed in toward the center of the watch by chronograph button, end A of starter push piece is forced away from the center of the watch and because end A of starter push piece is connected to the flyback lever, the flyback lever is also forced from the center of the watch.

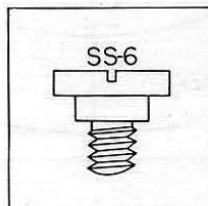

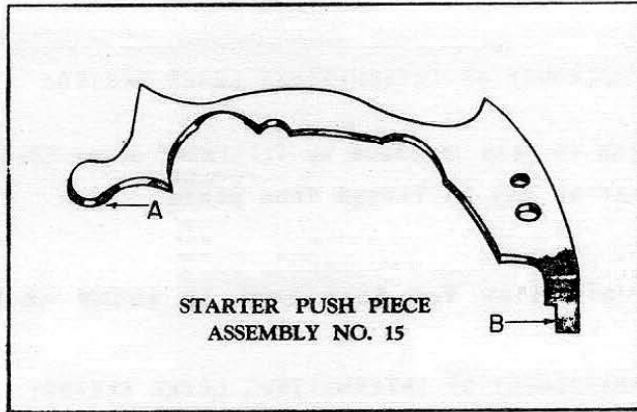

OILING

THE SHOULDER SCREW SS-6 THAT STARTER PUSH PIECE PIVOTS ON SHOULD BE SLIGHTLY MOISTENED WITH OIL.

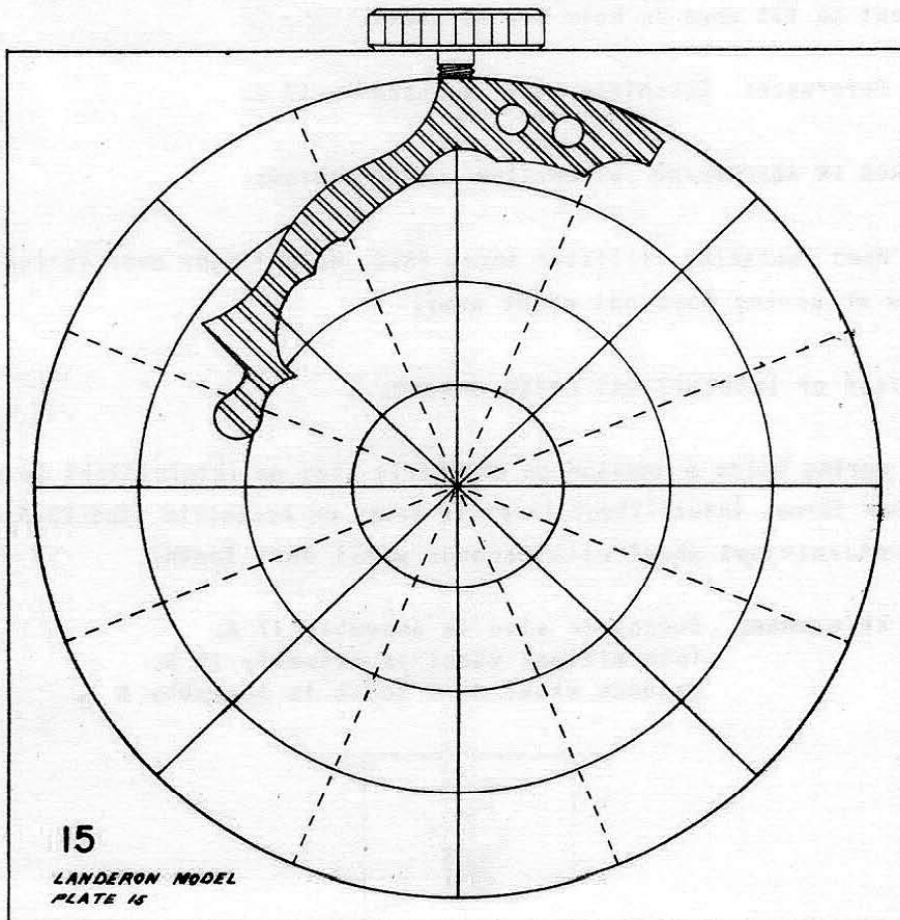

(A) DISASSEMBLY PROCEDURE OF INTERMITTENT LEVER SPRING:

This spring is held in place by fillister screw FS-6. When this screw is removed, spring may be lifted from plate.

(The shape of screw for this part is shown at bottom of page)

(B) HAZARDS IN DISASSEMBLY OF INTERMITTENT LEVER SPRING:

When removing screw that holds intermittent lever spring in place, hold finger over spring so that spring cannot shoot away.

(C) ASSEMBLY PROCEDURE OF INTERMITTENT LEVER SPRING:

This small wire spring is placed on movement with loop in spring over hole for fillister screw FS-6. The straight end of spring B is placed on inside of eccentric stud on intermittent lever. The other end of Spring A is bent to fit down in hole H-2 in plate.

Reference: Eccentric stud is Assembly 17 A.

(D) HAZARDS IN ASSEMBLING INTERMITTENT LEVER SPRING:

When replacing fillister screw FS-6, hold finger over spring so that screw or spring does not shoot away.

(E) FUNCTION OF INTERMITTENT LEVER SPRING:

This spring holds a tension on eccentric stud on intermittent lever. This tension forces intermittent lever to pivot on eccentric stud ES-5 engaging the intermittent wheel with seconds wheel dart tooth.

Reference: Eccentric stud is Assembly 17 A.
Intermittent wheel is Assembly 17 B.
Seconds wheel dart tooth is Assembly 5 A.

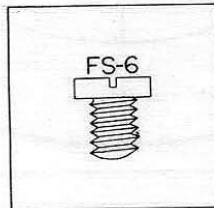

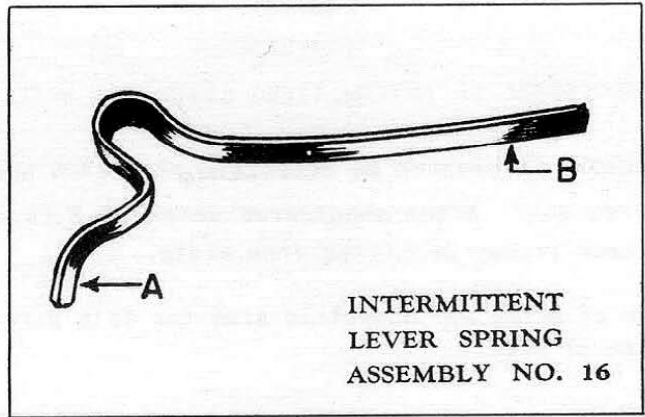

OILING

THE INTERMITTENT LEVER SPRING SHOULD NOT BE OILED.

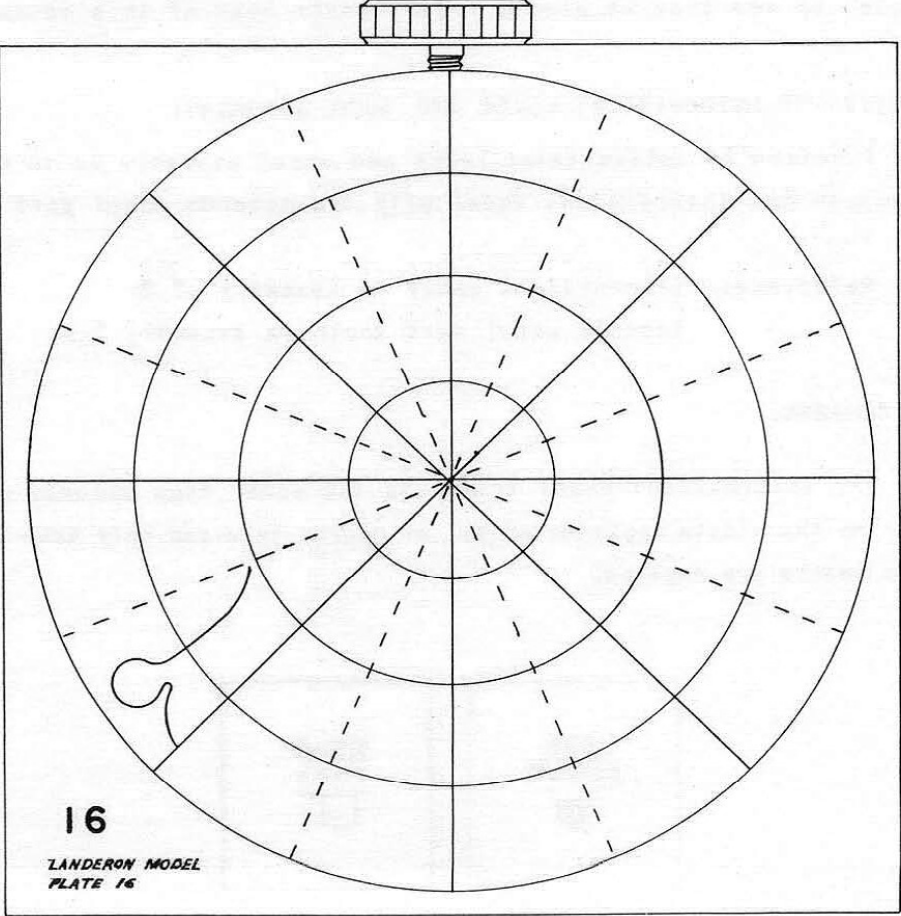

PART NO. 17

(A) DISASSEMBLY PROCEDURE OF INTERMITTENT LEVER AND WHEEL ASSEMBLY:

This assembly is pivoted on eccentric stud ES-5 and held in place by shouldered screw SS-7. After shouldered screw SS-7 is removed that holds assembly in place it may be lifted from plate.

(The shape of screw and eccentric stud for this part is shown at the bottom of page.)

(B) ASSEMBLY PROCEDURE OF INTERMITTENT LEVER AND WHEEL ASSEMBLY:

Replace this assembly in recess in plate with hole in assembly over eccentric stud ES-5 in plate as assembly pivots on this stud. Replace shouldered screw SS-7 in slot C of intermittent lever and wheel assembly.

(C) HAZARDS IN ASSEMBLY OF INTERMITTENT LEVER AND WHEEL ASSEMBLY:

After replacing shouldered screw SS-7 intermittent lever should be checked to see that it pivots freely under head of this screw.

(D) FUNCTION OF INTERMITTENT LEVER AND WHEEL ASSEMBLY::

Function of intermittent lever and wheel assembly is to engage and disengage the intermittent wheel with the seconds wheel dart tooth.

Reference: Intermittent wheel is Assembly 17 B.
Seconds wheel dart tooth is Assembly 5 A.

(E) REMARKS:

The intermittent wheel transmits the power from seconds wheel dart tooth to the minute register wheel, of course this can only take place when these wheels are engaged.

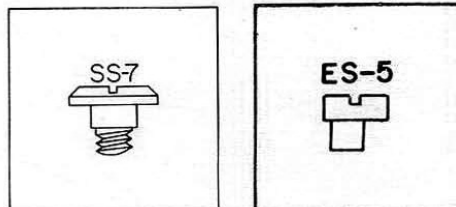

INTERMITTENT LEVER &
WHEEL ASSEMBLY
ASSEMBLY NO. 17

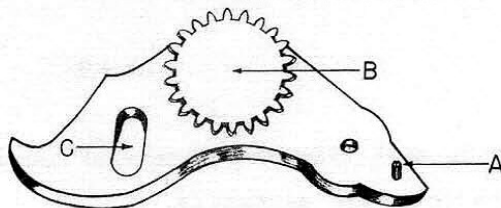

OILING

THE ECCENTRIC STUD ES-5 THAT INTERMITTENT LEVER PIVOTS ON SHOULD BE SLIGHTLY MOISTENED WITH OIL. DO NOT OIL INTERMITTENT WHEEL.

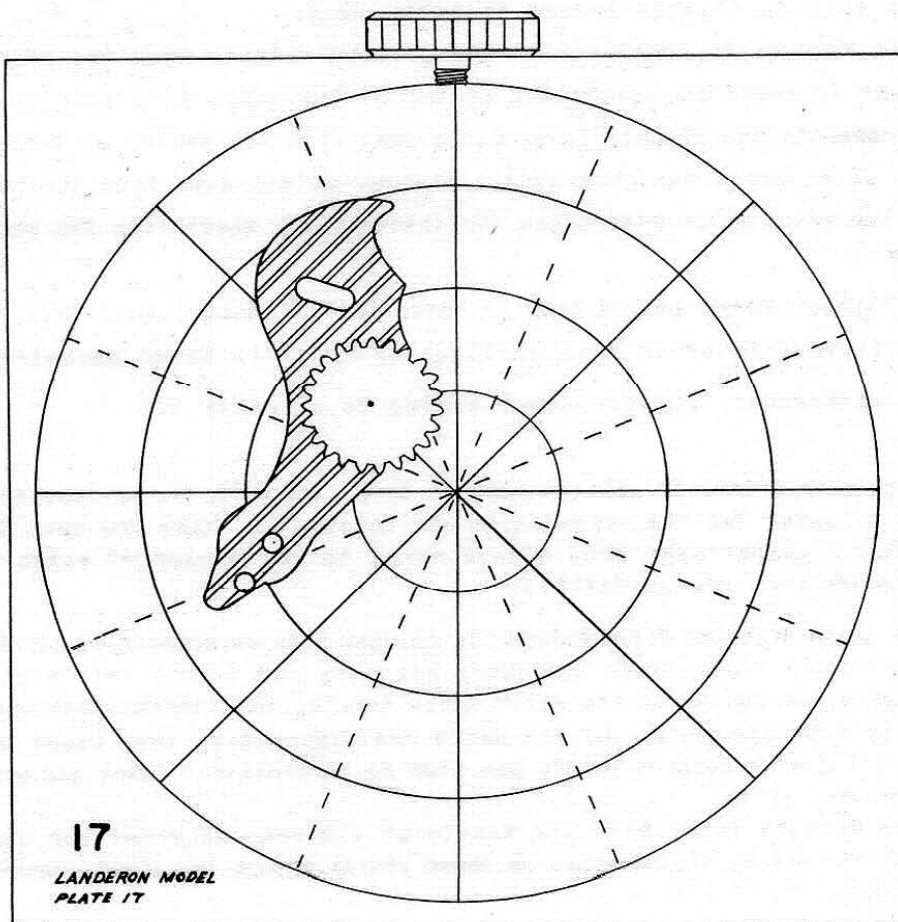

(Continued from Page 13.)

HOW FUNCTION TAKES PLACE:

FLYBACK LEVER:

The flyback lever in this type of chronograph has complete control of the function of the chronograph mechanism.

Suppose we start with the flyback lever as far as possible from the center of watch and follow the function of this lever step by step as it is moved towards center of watch.

1. First push push piece for setting back to zero, Assembly 14, in as far as it will go and release it. When you have done this the flyback lever should have moved toward the center of watch, and results of this are as follows:

- (a) First of all the flyback lever has a eccentric stud attached to it. See stud on flyback lever, Assembly 13 A.

This stud is in contact with the pivoted detent. When the flyback lever is moved in toward the center of the watch this stud that is attached to the flyback lever moves away from the center of the watch and also forces the chronograph pivoted detent away from the center of the watch which disengages the intermediary wheel from the seconds wheel.

Remarks: Flyback lever spring fits in notch B of flyback lever. This holds flyback lever in this position until it is moved manually.

Reference: Flyback lever spring is Assembly 12.

2. Now push push piece for setting back to zero, Assembly 14, in toward the center of watch for the second time and release it. When you have done this the flyback lever should have moved to the center of watch and results of this are as follows:

- (a) The angle that the flyback lever is cut on, hits on eccentric stud ES-4 on intermittent lever and wheel assembly and forces this stud in toward the center of the watch. Thus forcing the intermittent wheel away from the center of the watch and disengaging this wheel with dart tooth on seconds wheel. See stud on intermittent lever and wheel Assembly 17 A.

- (b) The flyback lever hits the hearts on the seconds wheel and minute register wheel. The pressure on these hearts brings the wheels connected to these hearts back to their original starting position.

FLYBACK LEVER

The flat ends "E" and "F" of the flyback lever should be highly polished. Any pits of rust or roughness at this location may result in the flyback lever not returning the seconds wheel and minute register wheel to a zero position.

The seconds wheel is returned to a zero position by the end "F" of the flyback lever contacting the heart on this wheel. This forces the heart to turn the wheel to a zero position.

The heart on the seconds wheel is set eccentric. When the flat end of the flyback lever contacts the heart, it forces the heart to turn. The heart will turn until the flat end of the flyback lever sets across the two lobes at top of heart. With the pressure equalized at these points, the heart will turn no further and this would be a zero position for this wheel.

If these wheels have turned less than 160 degrees from a zero position when the flyback lever is brought in contact with the hearts, they will turn in the opposite direction to which they were turning to bring these wheels back to a zero position. On the other hand, if the wheels have turned past 160 degrees from a zero position, the flyback lever will force the hearts to continue to turn in the direction they were turning until they reach a zero position. The degree used above should not be taken as exactly correct, as it is approximate. This degree varies in most chronographs from 150 degrees to 170 degrees.

When the flyback lever is forced toward the center of the watch and held in this position, check the seconds wheel and minute register wheel to see if either of these wheels will turn. The minute register wheel should turn slightly at this point, but the seconds wheel should be held very tight by the flyback lever. It is most essential that the seconds wheel be held stationary by the flyback lever at a zero position. In the case of the minute register wheel, it does not have to be held absolutely stationary by the flyback lever. The minute register pawl will serve this purpose. The only thing that the minute register wheel should be checked for is to see that the minute register wheel will not turn far enough to one side or the other to let the minute register pawl drop into another tooth. This will assure that the minute register wheel will always be brought back to a zero position.

FUNCTIONAL RESULTS

After completely assembling the chronograph, check to see that parts function correctly. Below are listed a number of functional results that should occur along with the most common errors that will prevent their occurrence.

To give us a starting point we will place watch pendant up with back of watch facing us.

I. PUSH BUTTON TO THE RIGHT OF THE PENDANT, RELEASE IT AND CHECK THE FOLLOWING:

- A. Check to see that intermediary wheel is properly engaged with seconds wheel.

CORRECTION: The following errors could prevent the intermediary wheel from properly engaging the seconds wheel.

1. The chronograph pivoted detent not pivoting freely.
2. The chronograph pivoted detent spring not having enough tension on chronograph pivoted detent to force it toward the center of the watch.
3. The flyback lever not moving to its proper position will cause improper engagement of these wheels.
4. Eccentric studs can cause faulty engagement of the intermediary wheel with the seconds wheel. (Adjustment of eccentric studs are on Page 19.

- B. Check to see that dart tooth on seconds wheel is engaged with teeth on intermittent wheel.

CORRECTION: If dart tooth does not engage with teeth on intermittent wheel. The following errors could cause this:

1. If the intermittent lever spring does not hold enough tension on intermittent lever to force intermittent wheel in toward the center of the watch.
2. If intermittent lever and wheel assembly does not pivot freely.
3. Eccentric studs could also cause faulty engagement of intermittent wheel with seconds wheel dart tooth. (Adjustment of eccentric studs are on Page 19.

- C. Check to see that second hand moves forward in a steady manner with no jumping or jerking.

CORRECTION: This irregular movement of the second hand is usually caused by the seconds wheel tension spring not holding proper tension on seconds wheel.

- D. Check the minute register hand to see that it moves forward exactly one minute each time the sweep second hand makes one revolution.

CORRECTION: If the minute register hand does not move forward exactly one minute each time the sweep second hand makes one revolution. The following errors could cause this:

1. Improper tension of minute register pawl on minute register wheel.
2. Working end of pawl not polished.
3. Of course, improper fitted hand could cause hand to move incorrectly.

Continued on next page.

FUNCTIONAL RESULTS

(Continued)

2. PUSH BUTTON TO LEFT OF PENDANT TOWARD CENTER OF WATCH AS FAR AS IT WILL GO, RELEASE IT AND CHECK THE FOLLOWING:

- A. Check to see that push piece for setting back to zero has returned to original position after pressure has been released.

CORRECTION: The push piece may be prevented from returning to its original position by the following errors:

1. The push piece binding and not pivoting freely.
2. The push piece for setting back to zero spring not holding enough tension on push piece to force it away from the center of the watch.
3. End of push piece having burrs on it and catching on flyback lever could prevent push piece from returning to its original position.

- B. Check to see that intermediary wheel is disengaged from seconds wheel.

CORRECTION: These two wheels could be prevented from disengaging by the following errors:

1. Failure of flyback lever to move to its proper position.
2. The chronograph pivoted detent binding and not pivoting freely.
3. Improper adjustment of eccentric studs.
(Adjustment of eccentric studs shown on Page 19.)

- C. Check to see that seconds wheel stays in a stationary position and does not move even if watch is bumped.

CORRECTION: The seconds wheel moving and not staying in a stationary position, can be caused by the seconds wheel tension spring not holding enough tension on seconds wheel.

3. PUSH BUTTON TO LEFT OF PENDANT A SECOND TIME, RELEASE IT AND CHECK THE FOLLOWING:

- A. Check to see that the ends of flyback lever are in contact with hearts, on seconds wheel and minute register wheel.

CORRECTION: If the ends of flyback lever are not in contact with hearts on seconds wheel and minute register wheel, the following error can cause this:

1. Flyback lever spring improperly adjusted to flyback lever. The flyback lever spring should hold end of flyback lever in contact with hearts.

- B. Check to see that seconds wheel dart tooth is disengaged from intermittent wheel.

CORRECTION:

1. Improper adjustment of eccentric screws usually prevents these two wheels from disengaging.
2. Adjustment of eccentric shown on Page 19.

- C. Check to see that minute register pawl lies directly in the center of two of minute register wheel teeth. Failure to have this adjusted properly will result in minute register hand moving after flyback lever is moved away from hearts.

CORRECTION:

1. Adjust minute register pawl so that it does lie directly center of two teeth when minute register hand has been returned to a zero position by flyback lever.

ADJUSTING ECCENTRIC STUDS - THINGS TO CHECK

In disassembling or assembling chronograph it is a good policy not to turn eccentric studs. These eccentric studs are used to adjust one part to another and naturally in turning these studs you will lose the desired adjustment of the chronograph mechanism which will cause the chronograph to function incorrectly. Another reason for not turning these studs unless it is necessary is that they soon become loose and will not hold the desired adjustment.

Listed below are a number of depthings and adjustments controlled by eccentric studs.

1. Check depthings of wheel over fourth wheel teeth with intermediary wheel teeth.
(Correction) If this depthing is incorrect, you can correct this by adjusting eccentric stud ES-1 that chronograph pivoted detent pivots on.
Reference: Wheel over fourth wheel is Assembly 1.
Intermediary wheel is Assembly 8.
2. Check depthings of teeth on intermediary wheel with seconds wheel.
(Correction) If depthing is incorrect, you correct this by adjusting eccentric stud ES-2 and eccentric stud ES-1
Reference: Intermediary wheel is Assembly 8.
Seconds wheel is Assembly 5.
3. Check depthings of intermittent wheel with dart tooth on seconds wheel.
(Correction) If this depthing is incorrect, you can correct this by adjusting eccentric stud ES-6.
Reference: Intermittent wheel is Assembly 17 B.
Seconds wheel dart tooth is Assembly 5 A.
4. Check depthing of intermittent wheel teeth with minute register wheel teeth.
(Correction) If depthing is incorrect, you can correct this by adjusting eccentric stud ES-5. The intermittent lever pivots on this stud.
Reference: Intermittent wheel is Assembly 17 B.
Minute register wheel is Assembly 4.
5. Check intermediary wheel and make sure that it disengages with the seconds wheel when flyback is moved in toward the center of the watch.
(Correction) If intermediary wheel does not disengage from seconds wheel when flyback is moved in toward the center of the watch, you can adjust eccentric stud ES-3 on flyback lever to correct this.
Reference: Intermediary wheel is Assembly 8.
Seconds wheel is Assembly 5.
6. Check intermittent wheel and make sure it disengages from seconds wheel dart tooth when flyback is brought all the way into the center of the watch.
(Correction) If intermittent wheel does not disengage from seconds wheel dart tooth when flyback is brought all the way into the center of the watch, then you adjust eccentric stud ES-4 on intermittent lever.
Reference: Intermittent wheel is Assembly 17 B.
Seconds wheel is Assembly 5 A.

ADJUSTING ECCENTRIC STUDS

DO NOT REMOVE THESE STUDS

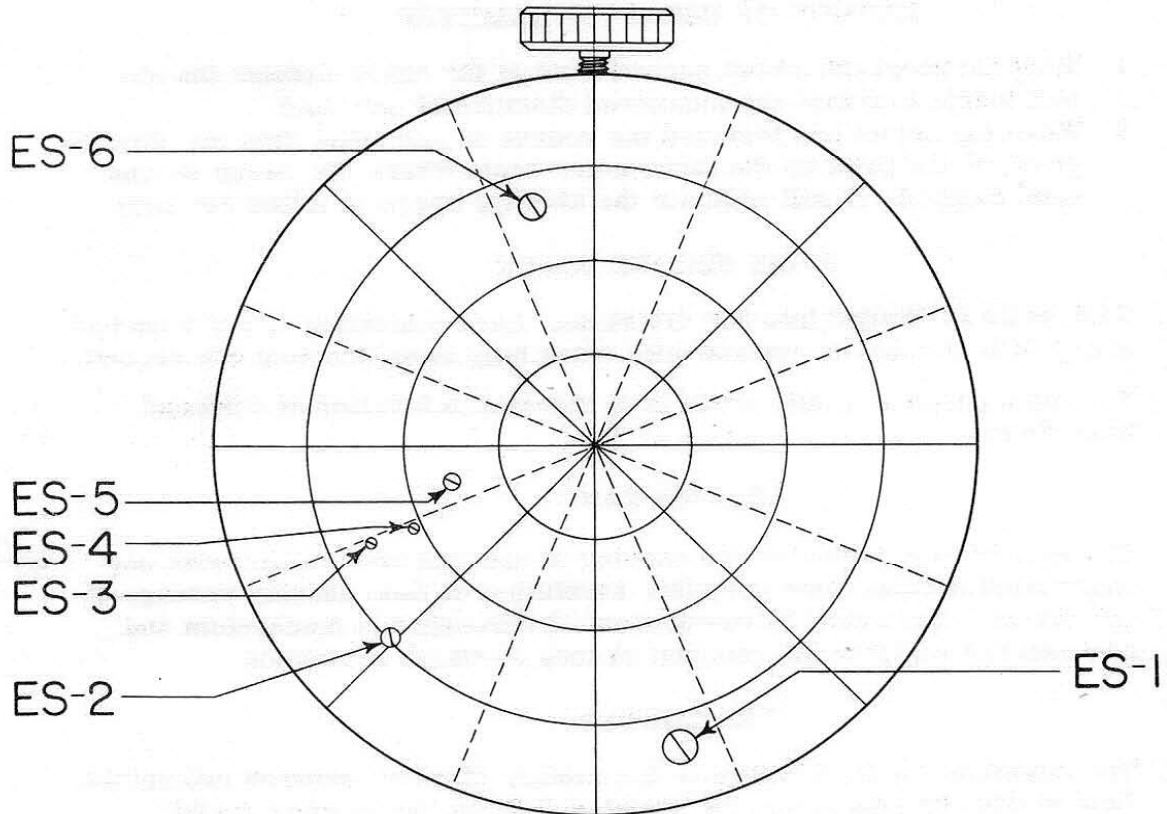

CAUTION

In disassembling or assembling chronograph it is a good policy not to turn eccentric studs. These eccentric studs are used to adjust one part to another and naturally in turning these studs you will lose the desired adjustment of the chronograph mechanism which will cause the chronograph to function incorrectly. Another reason for not turning these studs unless it is necessary is that they soon become loose and will not hold the desired adjustment.

DIRECTIONS FOR READING CHRONOGRAPH DIAL

THE TACHOMETER

- A. The tachometer is used to indicate the speed of an object in miles per hour. A tachometer can only indicate the average speed of an object traveling over a course of a measured mile.

METHOD OF USING TACHOMETER

1. Start chronograph sweep second hand at the exact moment the object starts to travel the measured distance of one mile.
2. When the object has traveled the course of one mile, stop the chronograph at the point on the tachometer scale where the sweep second hand stopped. It will indicate the average speed in miles per hour.

SPLIT SECOND SCALE

- B. This scale is divided into 300 divisions. Each indicating $1/5$ of a second every fifth division is marked with extra long lines denoting one second.

The main purpose of this scale is to measure a fraction of a second accurately.

SECOND HAND

- C. The second hand indicates the passing of seconds and should move one space each second. One complete revolution of hand denotes passage of one minute. This hand is independent of chronograph mechanism and continues to register the seconds as long as watch is running.

TELEMETER

- D. The telemeter is used to denote the number of miles between two points. This is done by comparing the speed of light to the speed of sound.

METHOD OF USING TELEMETER

1. Start chronograph sweep second hand when you see lightning.
2. Stop the chronograph sweep second hand when you hear the thunder. The point on the telemeter scale where the sweep second hand stopped will indicate the distance in miles the lightning is away from you.

MINUTE REGISTER

- E. The minute register hand registers the number of minutes the chronograph has been in operation. This hand should move forward one space each minute that the chronograph is in operation.

THE CHRONOGRAPH DIAL

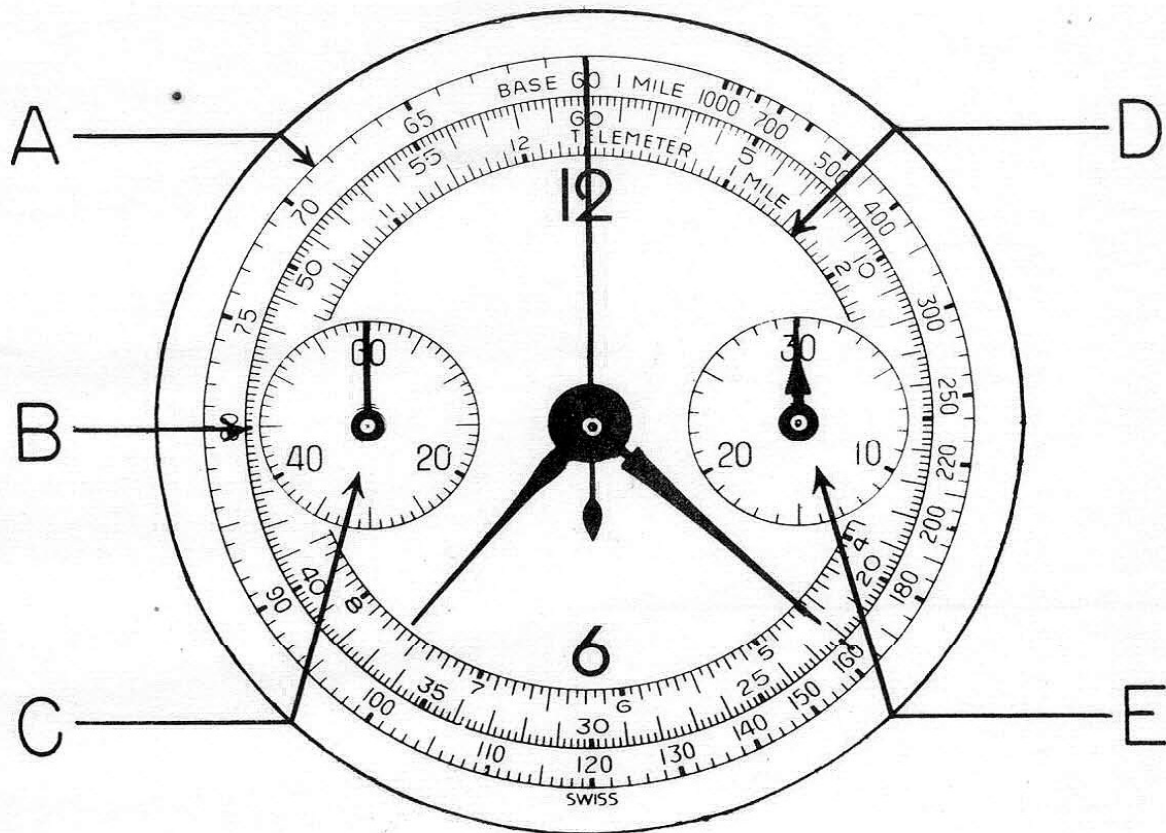

SETTING THE HANDS CORRECTLY ON A CHRONOGRAPH:

After the chronograph is completely assembled and in working condition, place chronograph in its case. Now replace the hands, replace the hour hand, minute hand and second hand as you would on a regular watch. At this point, do not replace the sweep second or the minute register hand. Now push the button and bring the flyback lever in toward the center of the watch. When the flyback lever is held in toward the center of the watch, place the sweep second hand at 60 on split second scale 'B'. Place the minute register hand at 30 on minute register scale 'E'. After these hands are replaced, start chronograph mechanism with sweep second hand turning. Leave chronograph mechanism run for at least one minute, now push the button to bring the flyback lever in toward the center of the watch again, and check to see that the minute register hand and the sweep second hand goes back to their original position.