

WORLD'S ONLY
FULLY ILLUSTRATED
CHRONOGRAPH WATCH COURSE
VOLUME 5

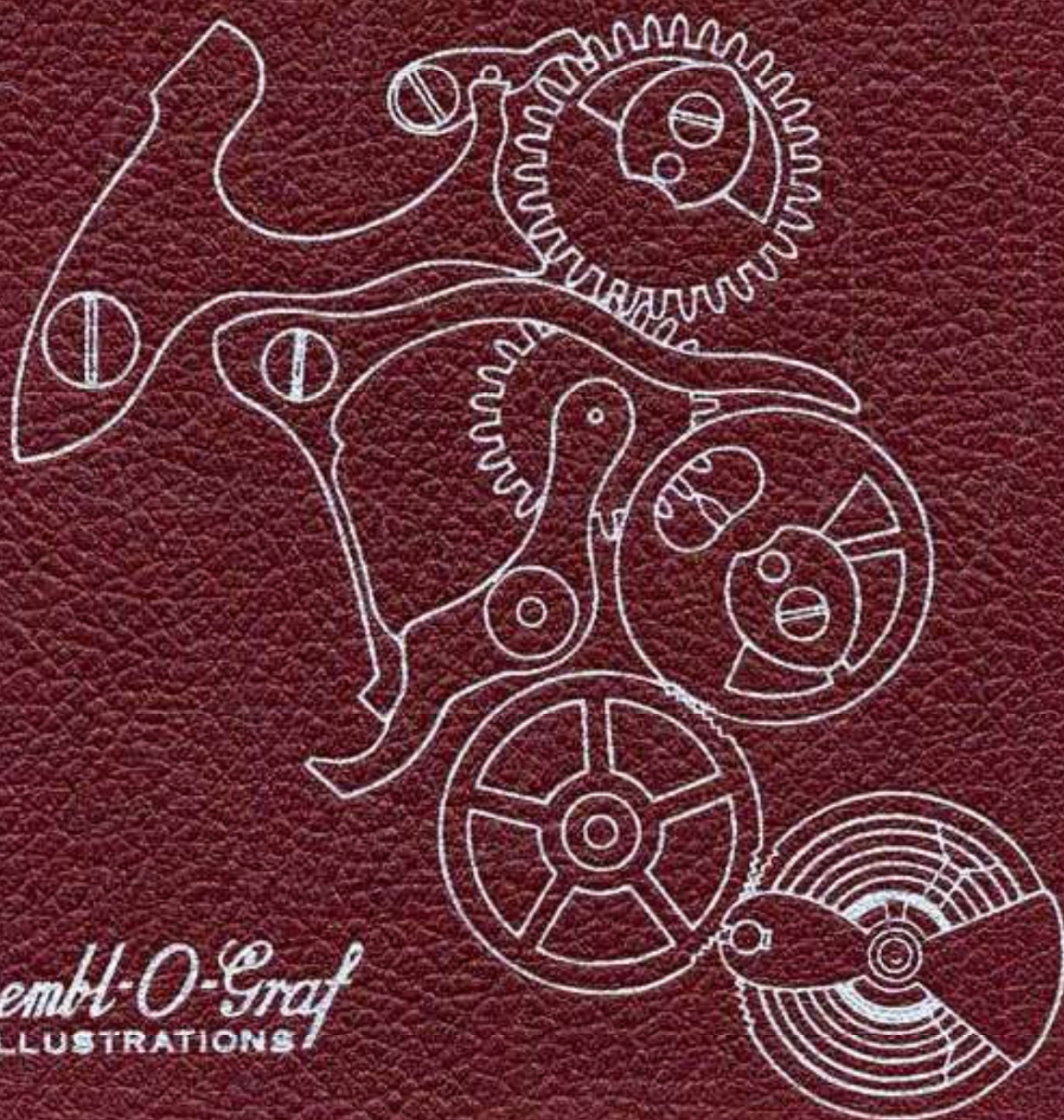

Essembl-O-Graf
ILLUSTRATIONS

IDENTIFICATION OF CHRONOGRAPH

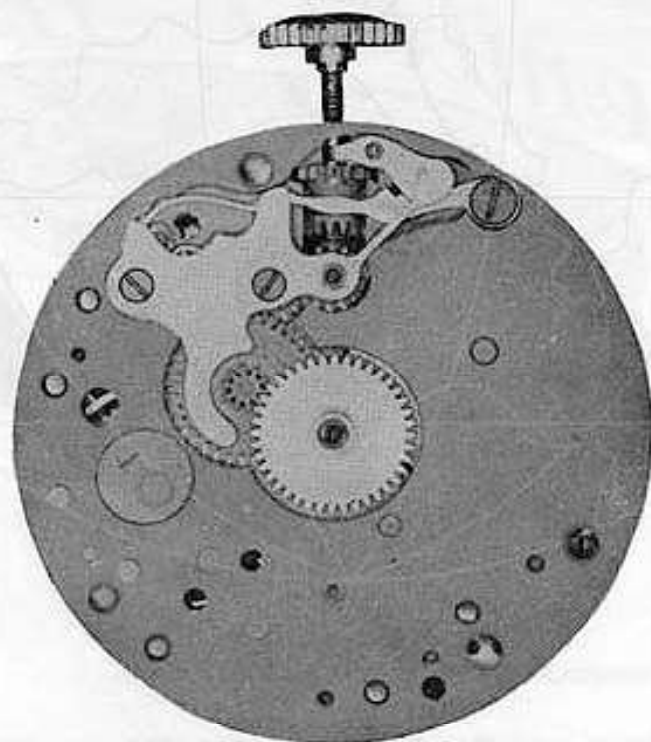

10 1/2 L



VALJOUX
CAL. 69



ESEMBL-O-GRAF

THE WORLD'S FIRST FULLY
ILLUSTRATED TEXT BOOK
ON
CHRONOGRAPH REPAIRING
AND ADJUSTING

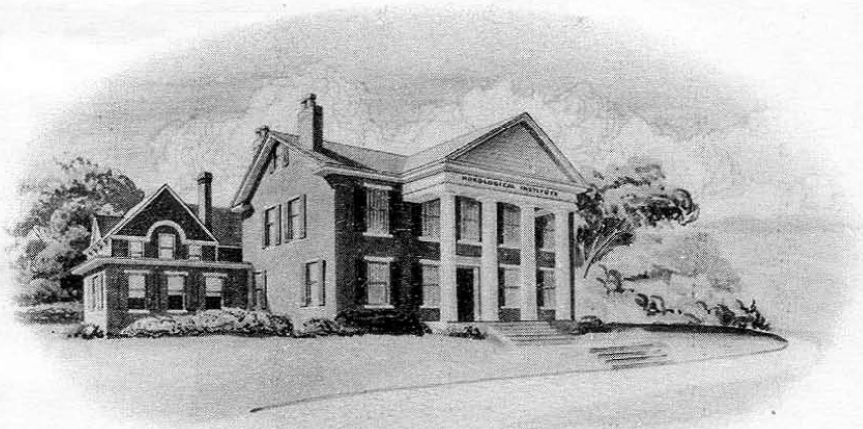

BY
William O. Smith, Sr.
PRESIDENT AND TECHNICAL DIRECTOR
AND
William O. Smith, Jr.
CHIEF ENGINEER, RESEARCH LABORATORIES

WESTERN PENNSYLVANIA HOROLOGICAL INSTITUTE, INC.
PITTSBURGH, PENNSYLVANIA

INSTRUCTIONS

For use of book

DISASSEMBLY OF THE CHRONOGRAPH MECHANISM:

1. Study the isometric drawing at top of page 1-A. The isometric drawing was made for the following purposes:
 - A. It helps to identify the part to be removed.
 - B. This drawing aids in pointing out certain locations on the part that are mentioned in the oiling procedure.
 - C. The text refers to certain points on the part. These points are shown in the isometric drawing. This should aid you in finding the exact location on the part that is described in the text.
 - D. It helps you to know the shape of the part in case a new part has to be made.
2. At the bottom of the page 1-A is a photograph of a chronograph. In this photograph is the same part painted in black. The part is in its exact location that this part occupies in the watch. Find this location in the watch.
3. Read the disassembly procedure and the hazards in disassembly on page 1 in this book.
4. Remove this part in the same procedure as described in the text.
5. A very important item in disassembling a chronograph is keeping the screws in order, much time will be lost in putting the chronograph together if screws are mixed up. This means you have to hunt for each screw, sometimes trying three or four screws before finding the correct one. It cannot be stressed too strongly that care should be taken so that screws are not mixed up. The system that we advise for beginners, is to replace each individual screw after each part is removed. This naturally eliminates the hazard of mixing up the screws and will save you much time in the end. Do this at least until you become so thoroughly familiar with the chronograph that you no longer feel it is necessary.
6. Continue to follow this procedure throughout the book and disassemble each part until the last part of the chronograph is removed.

ASSEMBLY OF THE CHRONOGRAPH MECHANISM:

7. When you are ready to assemble the chronograph mechanism, study the isometric drawing on the last part in this book. This drawing should aid you in identifying the part to be assembled.
8. At the bottom of this page is a photograph of a chronograph. In this photograph is the same part painted in black. The part is in its exact location that this part occupies in the watch.
9. Read the assembly procedure and the hazards in assembling for the last part in this book. (Continued on next page)

INSTRUCTIONS (Continued)

10. Replace the part in its exact location as shown in photograph, using the procedure as described in the text.

11. After you find the correct location for this part in the watch, read the oiling procedure for this part. The oiling procedure for this part is located underneath the isometric drawing. It is best to read the oiling procedure before you put each part in place as there are certain parts that must be oiled immediately as it may prove difficult to oil them later.

12. Replace the screw that holds this part in place. Of course, the screws should be kept in order as we advised above, but if the screws are not in order or the watch was received with screws mixed up, you will find a screw drawn for each part that requires a screw at the bottom of the text page.

13. After replacing this part, replace the next part, etc., until the last part is replaced, which will be part No. 1. Each part should be replaced using the same procedure as described in the text.

(Naturally, the assembly of the chronograph is exactly the reverse of the disassembly)

14. After disassembling and assembling the chronograph mechanism, start on page 1 and read the function of this part. After reading the function of this part, continue to read the function of each part throughout the book. Study each part, one at a time. This text should help you to understand more fully the purpose of each part in the chronograph mechanism.

15. Now put movement in its case with dial on, then replace hands.

16. Study the text on functional results in this book, and check the chronograph mechanism as described in this text.

NOMENCLATURE OF PART FOR CHRONOGRAPH MECHANISM













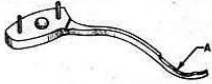
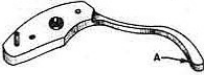
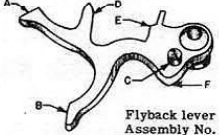
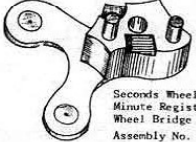
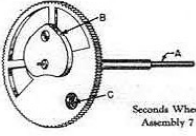

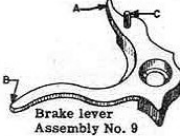
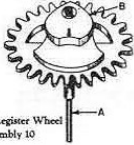
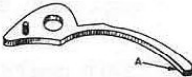
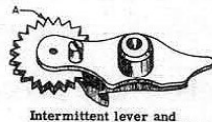
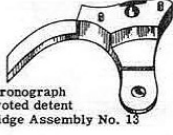
17. After you have become familiar with the chronograph mechanism, you can disassemble and assemble the chronograph by using the nomenclature of parts as a guide. This makes it possible for you to use a procedure without going through each page in the book.

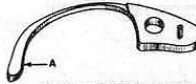
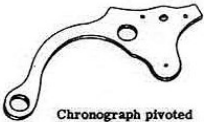
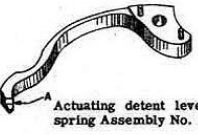
18. ADJUSTMENT OF ECCENTRIC STUDS:

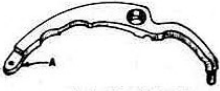
Read the text on adjustment of eccentric studs, this text should be read in reference to the eccentric stud picture. Now adjust each eccentric stud one at a time in the watch, as described in the text. Use the picture to show you the position of these studs.

19. On each page in this book the part number and the page number are the same. This makes it convenient for the reader and eliminates any confusion.

NOMENCLATURE OF PARTS FOR CHRONOGRAPH MECHANISM

 Wheel over fourth wheel Assembly No. 1	 Minute register pawl Assembly No. 2	 Flyback lever spring Assembly No. 3
 Brake lever spring Assembly No. 4	 Flyback lever Assembly No. 5	 Seconds Wheel & Minute Register Wheel Bridge Assembly No. 6
 Seconds Wheel Assembly 7	 Seconds wheel tension spring Assembly No. 8	 Brake lever Assembly No. 9
 Minute Register Wheel Assembly 10	 Intermittent lever spring Assembly No. 11	 Intermittent lever and wheel assembly Assembly 12
 Chronograph pivoted detent bridge Assembly No. 13	 Intermediary wheel Assembly No. 14	 Chronograph pivoted detent spring Assembly No. 15
 Chronograph pivoted detent Assembly No. 16	 Actuating detent lever spring Assembly No. 17	 Joint hook Assembly No. 18
 Actuating detent lever Assembly No. 19	 Push piece for setting back to zero Assembly No. 20	 Castle wheel pawl Assembly No. 21
 Castle wheel Assembly No. 22	 Sweep Second Hand	 Minute Register Hand

Chronograph
Button

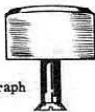

Chronograph
Button

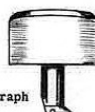

ADJUSTING ECCENTRIC STUDS-THINGS TO CHECK

LISTED BELOW ARE A NUMBER OF DEPTHINGS AND ADJUSTMENTS CONTROLLED BY THE ECCENTRIC STUDS.

1. CHECK DEPTHING OF WHEEL OVER FOURTH WHEEL AND THE INTERMEDIARY WHEEL TEETH.

CORRECTION: IF THIS DEPTHING IS INCORRECT, YOU CAN CORRECT IT BY ADJUSTING ECCENTRIC STUD ES-1.

REFERENCE: WHEEL OVER FOURTH WHEEL IS ASSEMBLY 1
INTERMEDIARY WHEEL IS ASSEMBLY 14

2. CHECK DEPTHING OF SECONDS WHEEL TEETH AND INTERMEDIARY WHEEL TEETH.

CORRECTION: IF THIS DEPTHING IS INCORRECT YOU CAN CORRECT IT BY ADJUSTING ECCENTRIC STUD ES-2 AND ES-1.

REFERENCE: SECONDS WHEEL IS ASSEMBLY 7
INTERMEDIARY WHEEL IS ASSEMBLY 14

3. CHECK DEPTHING OF INTERMITTENT WHEEL TEETH AND SECONDS WHEEL DART TOOTH.

CORRECTION: IF THIS DEPTHING IS INCORRECT, YOU CAN CORRECT IT BY ADJUSTING ECCENTRIC STUD ES-3.

REFERENCE: SECONDS WHEEL DART TOOTH IS ASSEMBLY 7-C
INTERMITTENT WHEEL IS ASSEMBLY 12-A

ADJUSTING ECCENTRIC STUDS

DO NOT REMOVE THESE STUDS

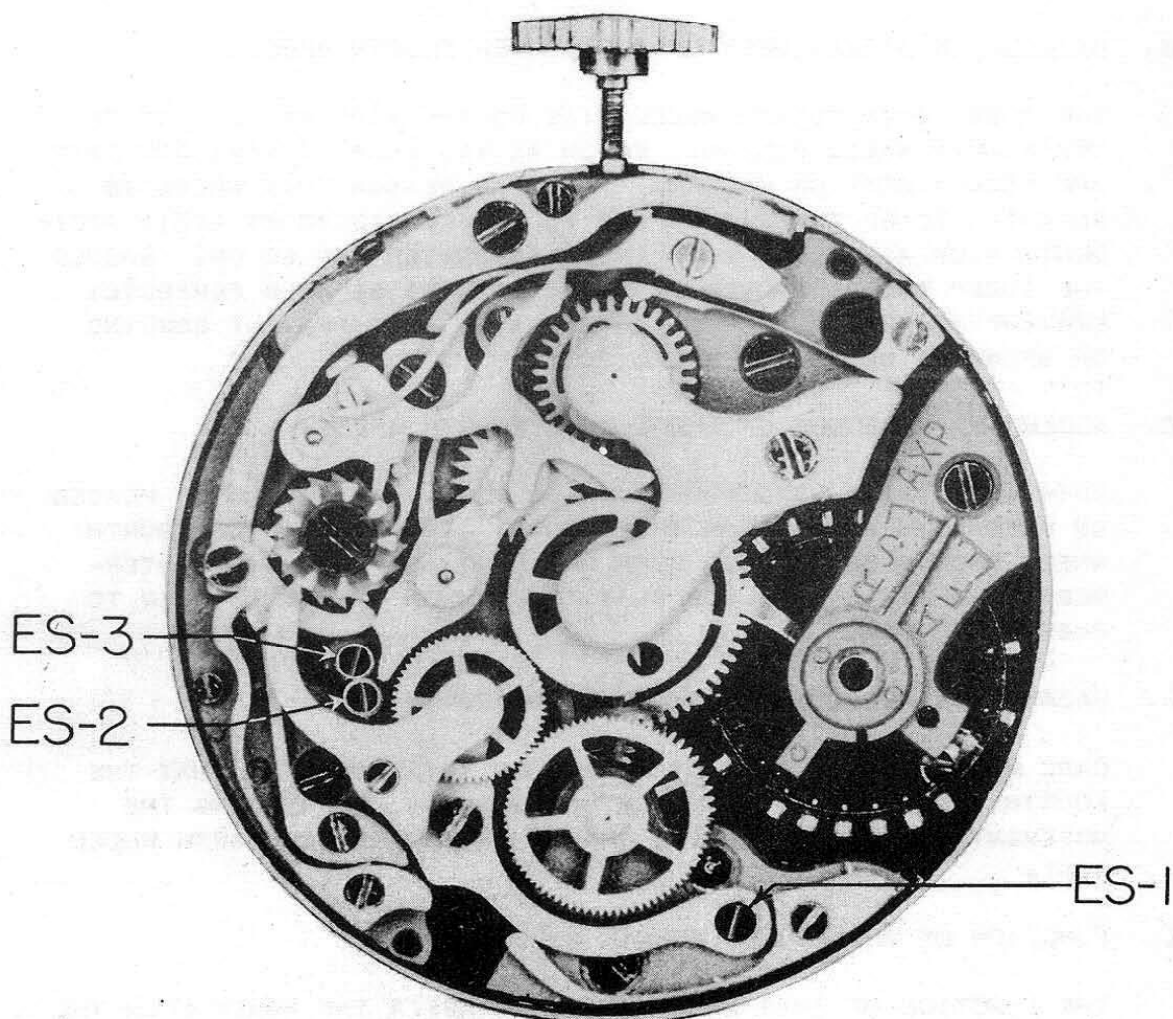

CAUTION

In disassembling or assembling chronograph it is a good policy not to turn eccentric studs. These eccentric studs are used to adjust one part to another and naturally in turning these studs you will lose the desired adjustment of the chronograph mechanism which will cause the chronograph to function incorrectly. Another reason for not turning these studs unless it is necessary is that they soon become loose and will not hold the desired adjustment.

PART NO. 1

A. DISASSEMBLY PROCEDURE OF WHEEL OVER FOURTH WHEEL:

THE WHEEL OVER FOURTH WHEEL FITS FRICTION TIGHT ON THE POST OF FOURTH WHEEL PINION. THIS WHEEL SHOULD BE REMOVED WITH A SWEEP WHEEL REMOVER. BUT CAN BE REMOVED WITH TWO SMALL THIN EDGE SCREWDRIVERS. THE SCREWDRIVERS ARE PLACED OPPOSITE EACH OTHER UNDER HUB OF WHEEL. ONE SCREWDRIVER IS TURNED CLOCKWISE WHILE THE OTHER ONE IS TURNED COUNTER-CLOCKWISE.

B. HAZARDS IN DISASSEMBLY OF WHEEL OVER FOURTH WHEEL:

THE WHEEL OVER FOURTH WHEEL FITS ON THE VERY SMALL POST OF THE FOURTH WHEEL PINION. WHICH AS YOU KNOW IS VERY DELICATE AND EASILY BENT OR BROKEN. THE MAIN REASON THIS WHEEL IS SELECTED TO BE THE FIRST PART TO BE REMOVED IS TO AVOID ACCIDENTS SUCH AS A SLIP WITH THE SCREWDRIVER AND SO ON. SHOULD THE SWEEP WHEEL REMOVER BE USED, IT MUST BE HELD PERFECTLY UPRIGHT IN REMOVING WHEEL. THIS WILL HELP PREVENT BENDING OR BREAKING OF FOURTH WHEEL POST.

C. ASSEMBLY PROCEDURE OF WHEEL OVER FOURTH WHEEL:

THIS WHEEL FITS OVER FOURTH WHEEL POST. IT SHOULD BE PLACED ON POST WITH HUB "A" ON WHEEL DOWN. THE WHEEL OVER FOURTH WHEEL SHOULD BE PRESSED DOWN UNTIL IT IS FLUSH WITH INTERMEDIARY WHEEL. A HOLLOW FLAT FACE PUNCH SHOULD BE USED TO PUSH WHEEL DOWN.

D. HAZARDS IN ASSEMBLY OF WHEEL OVER FOURTH WHEEL:

CARE MUST BE USED WHEN STAKING DOWN THIS WHEEL SO THAT THE FOURTH WHEEL POST IS NOT BENT OR BROKEN. BY HOLDING THE MOVEMENT LEVEL WILL LESSEN CHANCE OF DAMAGE TO FOURTH WHEEL POST.

E. FUNCTION OF WHEEL OVER FOURTH WHEEL:

THE FUNCTION OF THIS WHEEL IS TO TRANSFER THE POWER FROM THE TRAIN OF THE WATCH TO THE CHRONOGRAPH MECHANISM. THIS WHEEL CONTINUES TO TURN AS LONG AS WATCH IS RUNNING.

F. REMARKS:

MECHANICALLY, WE SHOULD REGARD THIS WHEEL AS THE INTERMEDIATE CHRONOGRAPH WHEEL, AS IT IS THE MAIN WHEEL WHICH TRANSFERS THE POWER FROM THE MOVEMENT TRAIN TO THE CHRONOGRAPH MECHANISM. THE SWISS TERM FOR THIS PART IS WHEEL OVER FOURTH WHEEL AND WE WILL USE THIS TERM TO DESCRIBE THIS WHEEL IN THIS TEXT.

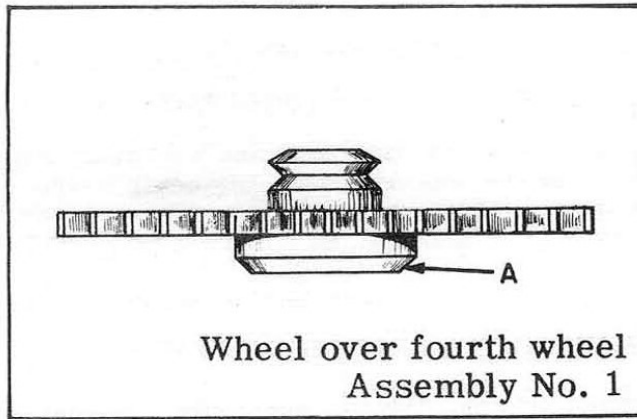

OILING

The wheel over fourth wheel should not be oiled.

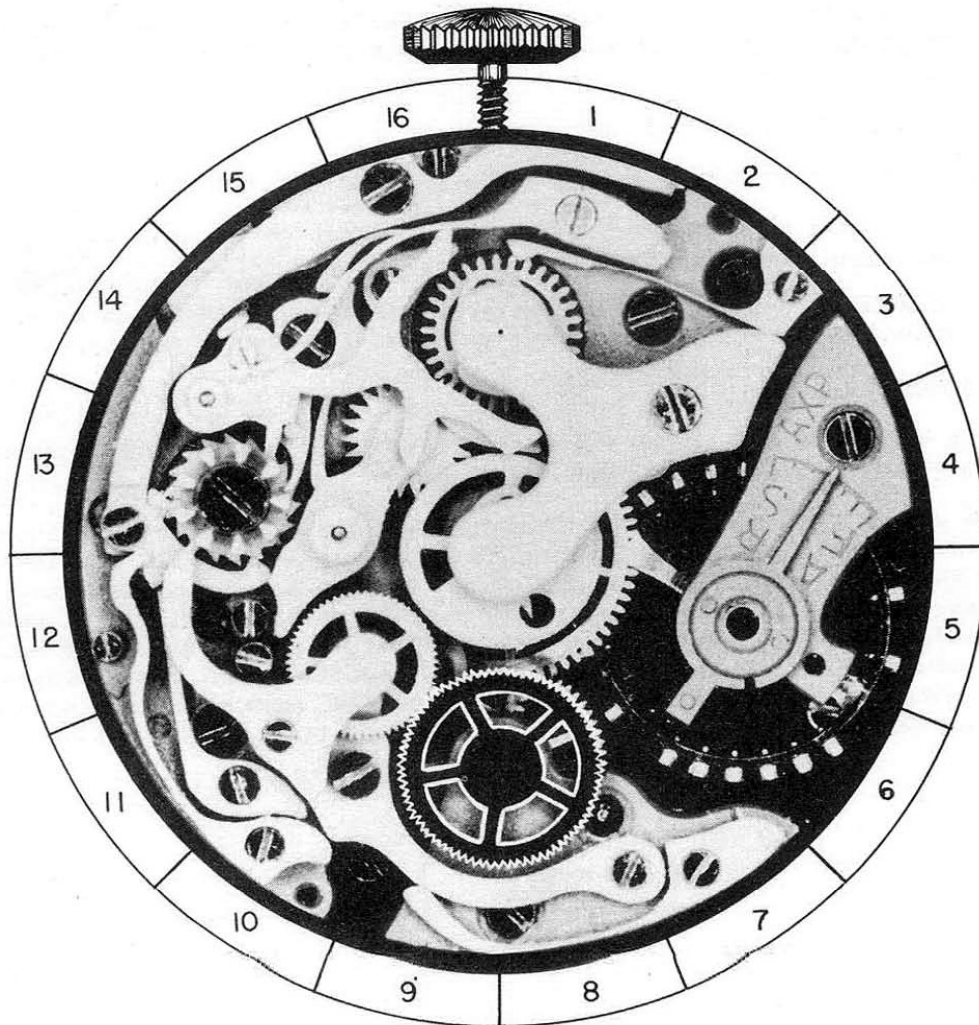

1-A

PART NO. 2

A. DISASSEMBLY PROCEDURE OF MINUTE REGISTER PAWL:

THE MINUTE REGISTER PAWL IS HELD IN PLACE BY STEADY PINS AND BEVELED COUNTERSINK SCREW BS-1. REMOVE SCREW AND LOOSEN PAWL FROM PLATE BY SLIDING A THIN BLADE SCREWDRIVER BETWEEN PAWL AND PLATE. WHEN STEADY PINS ARE FREE IN PLATE, PAWL MAY BE LIFTED FROM MOVEMENT.

(THE SHAPE OF SCREW FOR THIS PART IS SHOWN AT BOTTOM OF PAGE)

B. HAZARDS IN DISASSEMBLY OF MINUTE REGISTER PAWL:

THE TENSION SPRING ON THIS PAWL IS VERY THIN AND EASILY BENT. IT SHOULD BE REMOVED VERY CAREFULLY TO PREVENT BENDING, WHICH WILL CAUSE IT NOT TO FUNCTION PROPERLY.

C. ASSEMBLY PROCEDURE OF MINUTE REGISTER PAWL:

PLACE PAWL ON PLATE WITH STEADY PINS IN PAWL OVER PROPER HOLES IN PLATE. PRESS PAWL DOWN TO PROPER PLACE WITH BACK OF TWEEZERS AND REPLACE BEVELED COUNTERSINK SCREW BS-1.

D. HAZARDS IN ASSEMBLY OF MINUTE REGISTER PAWL:

BEFORE PRESSING PAWL TO PROPER PLACE ON PLATE, BE SURE END OF SPRING "A" IS NOT ON TOP OF TEETH ON MINUTE REGISTER WHEEL BUT IN THE CENTER OF TWO TEETH.

E. FUNCTION OF THE MINUTE REGISTER PAWL:

THE MINUTE REGISTER PAWL SERVES TWO PURPOSES:

1. IT HOLDS A TENSION ON MINUTE REGISTER WHEEL SO IT MOVES EXACTLY ONE TOOTH EACH MINUTE.
2. IT HOLDS A MINUTE REGISTER WHEEL IN A STATIONARY POSITION SO A BUMP CANNOT ALTER POSITION OF WHEEL UNTIL IT IS MOVED MECHANICALLY.

F. REMARKS:

AFTER REPLACING PAWL, PUSH FLY BACK TO CENTER OF WATCH UNTIL IT RETURNS MINUTE REGISTER WHEEL TO A ZERO POSITION.

WITH MINUTE REGISTER WHEEL IN THIS POSITION THE END "A" OF PAWL SHOULD LIE DIRECTLY IN THE CENTER OF TWO TEETH ON THIS WHEEL. THE TENSION OF THE END "A" OF PAWL ON TEETH OF MINUTE REGISTER WHEEL MUST BE VERY LIGHT AS ANY EXCESS TENSION WILL CAUSE THE MINUTE REGISTER WHEEL TO BE UNNECESSARILY HARD TO TURN. YET THE TENSION MUST BE STRONG ENOUGH TO HOLD THE MINUTE REGISTER WHEEL IN A STATIONARY POSITION UNTIL IT IS MOVED BY THE CHRONOGRAPH MECHANISM. THE END "A" OF PAWL MUST BE HIGHLY POLISHED AS ANY ROUGHNESS HERE WILL HINDER PROPER OPERATION OF CHRONOGRAPH.

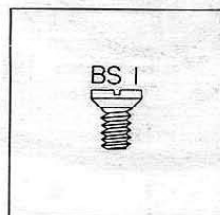

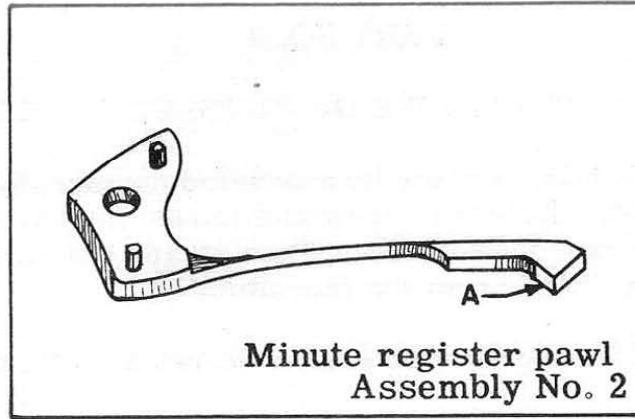

OILING

The minute register pawl should not be oiled.

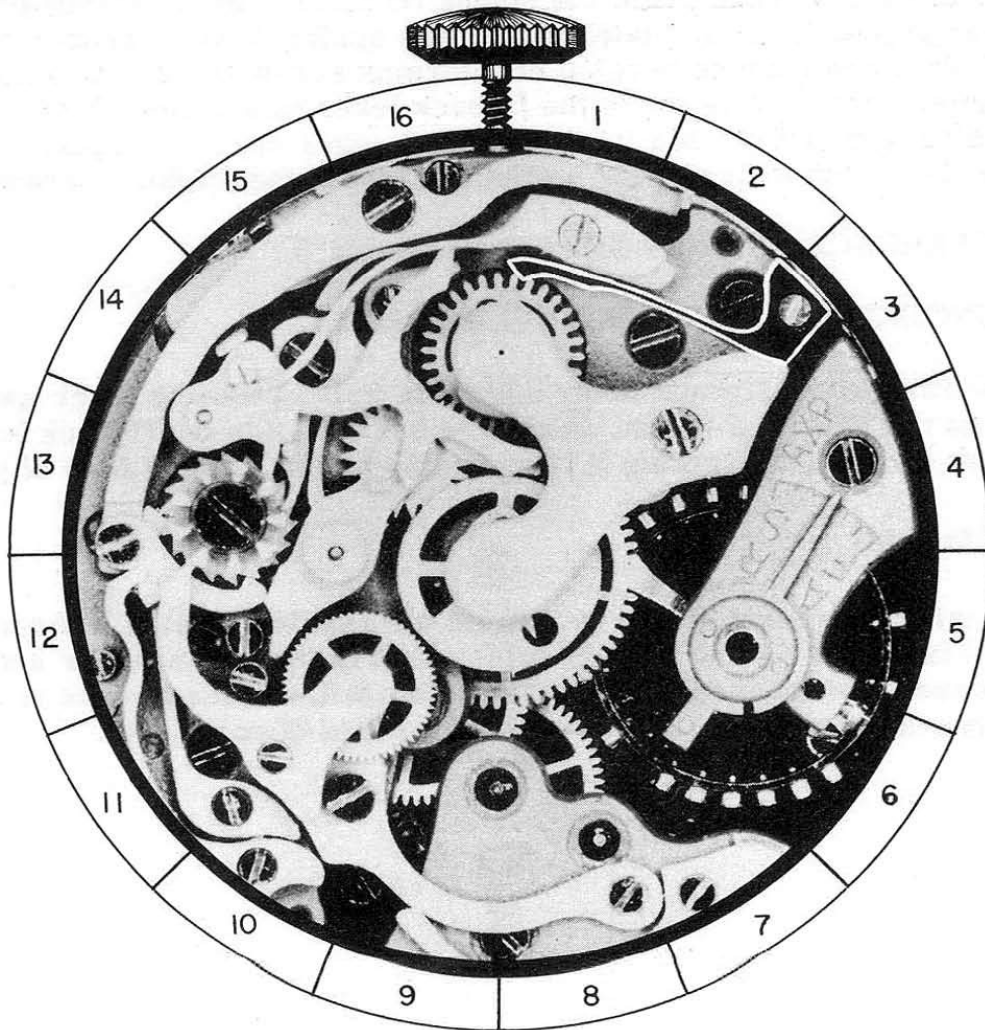

2-A

PART NO. 3

A. DISASSEMBLY PROCEDURE OF FLYBACK LEVER SPRING:

This spring is held in place by a beveled countersink screw BS-2 and steady pins. Remove screw and loosen the spring from plate with a thin blade screwdriver. When steady pins are free in plate, spring may be lifted from the movement.

(The shape of screw for this part is shown at bottom of page.)

B. HAZARDS IN DISASSEMBLY OF FLYBACK LEVER SPRING:

The screwdriver should be used carefully when loosening spring from plate to prevent marring of plate or spring.

C. ASSEMBLY PROCEDURE OF FLYBACK LEVER SPRING:

To replace this spring, first move the flyback lever in toward center of watch. Then place the spring on plate with the steady pins over proper holes in plate. Press the spring down to proper place on plate and replace beveled countersink screw BS-2 but do not tighten screw. Now move the flyback lever to position shown in photograph and lift end "A" of flyback lever spring and place it on inside of screw-head "C" on flyback lever; then tighten screw.

REFERENCE: Flyback lever is Assembly 5.

D. FUNCTION OF FLYBACK LEVER SPRING:

The function of flyback lever spring is to hold flyback lever away from the center of watch. Also, the spring holds the flyback lever down on post, preventing it from riding up and coming free of post.

REMARKS:

At this place I would like to remind the repairer that it is important that in removing and replacing these parts the screwdriver and tweezers be sharpened correctly. This will eliminate a lot of unnecessary breakage, marring of plate, loss of parts, etc.

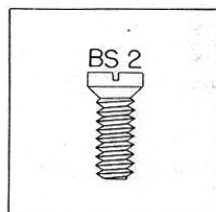

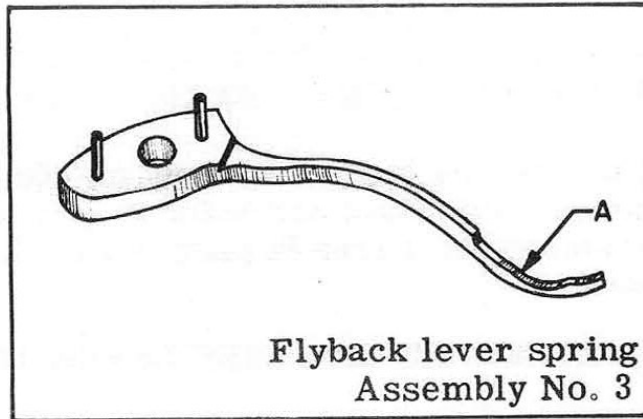

OILING

The end "A" of flyback lever spring should be slightly moistened with oil at the point it contacts screw "C" on flyback lever.

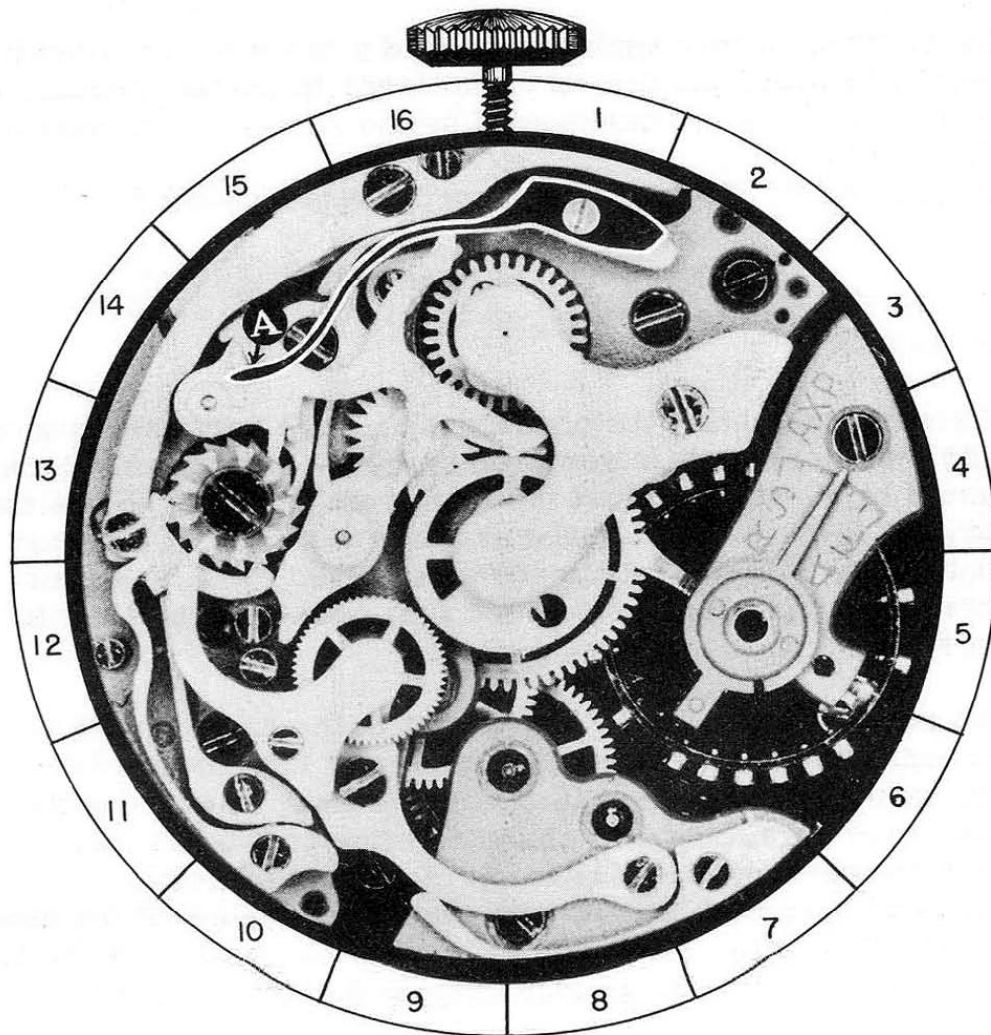

PART NO. 4

A. DISASSEMBLY PROCEDURE OF BRAKE LEVER SPRING:

This spring is now held in place by a steady pin. Remove spring by sliding a thin blade screwdriver between spring and plate. When steady pin is free in plate, spring may be lifted from movement.

B. ASSEMBLY PROCEDURE OF BRAKE LEVER SPRING:

Place spring on plate in position shown in photograph with the steady pin in spring over proper hole in plate. Now press spring down to proper place. The steady pins of the flyback lever pass through the brake lever spring into the plate holding this spring in position. The screw to hold this part in place is replaced after the flyback lever spring is replaced.

C. FUNCTION OF BRAKE LEVER SPRING:

The function of this spring is to hold a tension on the brake lever. This tension forces brake lever to contact seconds wheel when it is not disengaged by the chronograph mechanism.

REFERENCE: Flyback lever spring is Assembly 3.
Seconds wheel is Assembly 7.
Brake lever is Assembly 9.

REMARKS:

When disassembling the chronograph, each part should be carefully examined as it is removed from the movement. Each part should be checked against the isometric drawings to see that the part is the correct shape and is not broken. Each part should also be checked for any pits of rust, roughness, or burrs, and for worn parts which may cause the part not to work properly.

The replacement of a defective part in the chronograph may necessitate the complete disassembly of the chronograph. It will save time in the end to make this examination and the necessary corrections to each defective part while disassembling the chronograph. Through this close examination, you will soon become familiar with the various parts of the mechanism. This will enable you to quickly recognize a defective part and repair it before replacing in the chronograph.

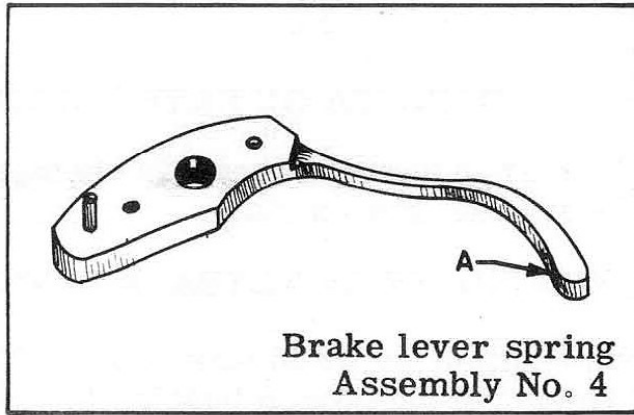

OILING

The end "A" of brake lever spring should be slightly moistened with oil at point it contacts brake lever.

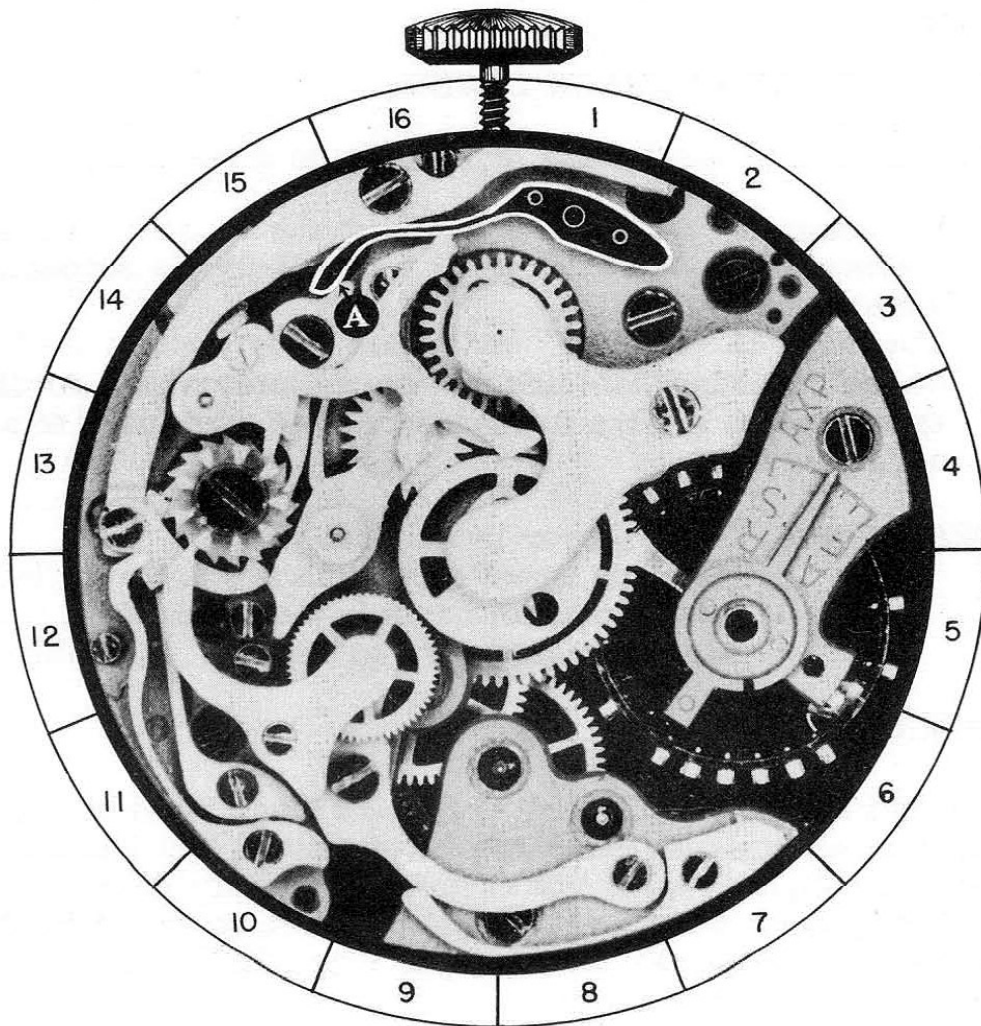

4-A

PART NO. 5

A. DISASSEMBLY PROCEDURE OF FLYBACK LEVER:

Move flyback lever to position shown in photograph. Then lift flyback lever from post in plate.

B. ASSEMBLY PROCEDURE OF FLYBACK LEVER:

Place lever in position shown in photograph. The screw-head "C" should be up and the hole in bushing in flyback lever over the post in plate. Now press lever down to proper position on post.

C. HAZARDS IN ASSEMBLY OF FLYBACK LEVER:

When pressing the flyback lever down to proper place, be sure that end "A" of flyback lever does not catch on seconds wheel and minute register wheel bridge, as this may damage lever.

D. FUNCTION OF FLYBACK LEVER:

The function of the flyback lever is to do three things:

1. It disengages the brake lever from the seconds wheel.
2. It disengages the intermittent wheel from the seconds wheel dart tooth.
3. The ends "A" and "B" of flyback lever contact the hearts on the seconds wheel and minute register wheel, forcing these wheels and the hands attached to them back to a zero position.

REFERENCE: Brake lever is Assembly 9.

Seconds wheel dart tooth is Assembly 7-C.

Seconds wheel heart is Assembly 7-B.

Minute register wheel heart is Assembly 10-B.

REMARKS:

The flat ends "A" and "B" of flyback lever must be highly polished as any roughness or pits of rust at this location may cause the flyback lever not to function correctly. When polishing these ends, care should be taken so as not to shorten one end more than the other, or they will not function correctly as described above.

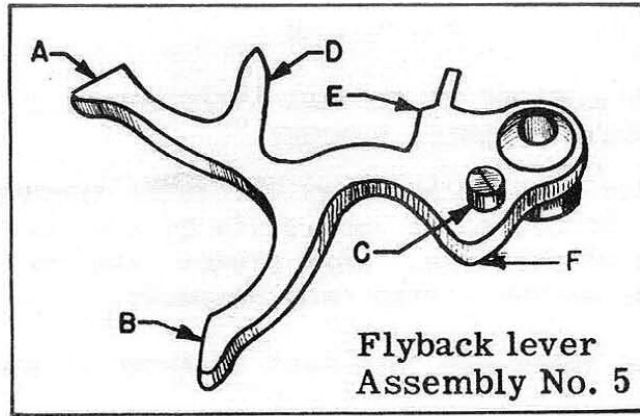

Flyback lever
Assembly No. 5

OILING

The flyback lever should be slightly moistened with oil at these points.

1. Stud that flyback lever pivots on.
2. Point 'D' on flyback lever that contacts intermittent lever.
3. Point 'E' on flyback lever that contacts pin 'C' on brake lever.
4. Point 'F' on flyback lever that contacts pushpiece for setting back to zero.

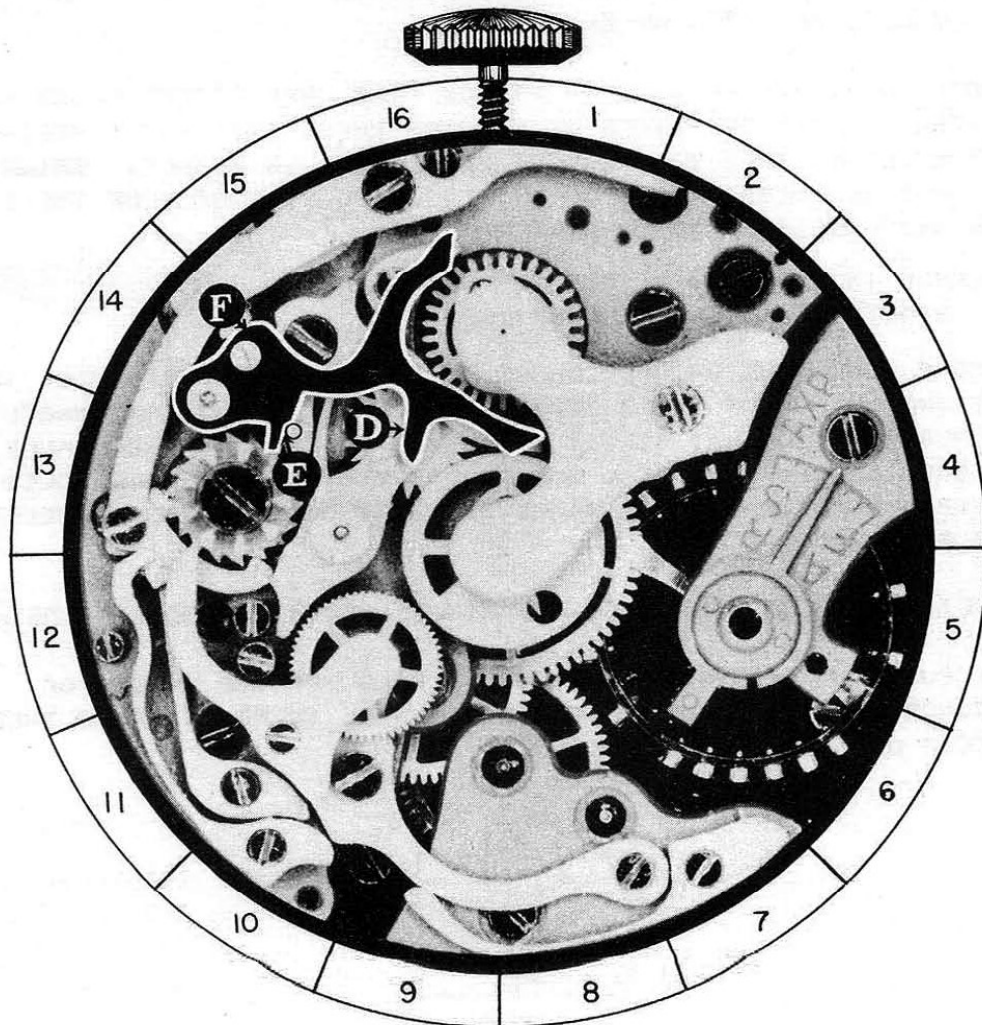

5-A

PART NO. 6

A. DISASSEMBLY PROCEDURE OF SECONDS WHEEL AND
MINUTE REGISTER WHEEL BRIDGE:

THIS BRIDGE IS HELD IN PLACE BY FILLISTER SCREW FS-1 AND
STEADY PINS, REMOVE SCREW AND LOOSEN BRIDGE FROM PLATE WITH
A THIN BLADE SCREWDRIVER. WHEN STEADY PINS ARE FREE IN
PLATE, BRIDGE MAY BE LIFTED FROM MOVEMENT.

(THE SHAPE OF SCREW FOR THIS PART IS SHOWN AT BOTTOM OF PAGE)

B. HAZARDS IN DISASSEMBLY OF SECONDS WHEEL AND
MINUTE REGISTER WHEEL BRIDGE:

WHEN LOOSENING BRIDGE FROM PLATE, AVOID TWISTING BRIDGE AS THIS
MAY DAMAGE PIVOTS ON WHEELS OR MAY CHIP JEWELS IN BRIDGE. THE
SCREWDRIVER SHOULD BE CAREFULLY USED TO PREVENT MARRING OF
BRIDGE AND PLATE.

C. ASSEMBLY PROCEDURE OF SECONDS WHEEL AND
MINUTE REGISTER WHEEL BRIDGE:

PLACE BRIDGE ON PLATE WITH STEADY PINS OVER PROPER HOLES IN
PLATE. PLACE TOP PIVOTS OF SECONDS WHEEL AND MINUTE REGIS-
TER WHEEL SO THEY WILL ENTER JEWEL HOLES IN BRIDGE. BRIDGE
MAY NOW BE PRESSED DOWN TO PROPER PLACE WITH BACK OF TWEEZ-
ERS AND FILLISTER SCREW FS-1 REPLACED.

D. HAZARDS IN ASSEMBLY OF SECONDS WHEEL AND
MINUTE REGISTER WHEEL BRIDGE:

BEFORE REPLACING BRIDGE, CHECK TO SEE THAT SECONDS WHEEL IS NOT
SETTING ON TOP OF BRAKE LEVER. FAILURE TO HAVE THIS WHEEL IN
PROPER POSITION MAY RESULT IN DAMAGE TO SECONDS WHEEL WHEN
BRIDGE IS REPLACED. THE TOP PIVOTS MUST BE IN JEWEL HOLES
BEFORE PRESSING DOWN TO PLACE ON PLATE OR PIVOTS OR JEWELS
MAY BE DAMAGED.

E. FUNCTION OF SECONDS WHEEL AND MINUTE REGISTER WHEEL BRIDGE:

THE FUNCTION OF THIS BRIDGE IS TO HOLD THE TOP PIVOTS OF
SECONDS WHEEL AND MINUTE REGISTER WHEEL IN POSITION SO THESE
WHEELS CAN FUNCTION PROPERLY.

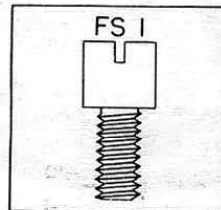

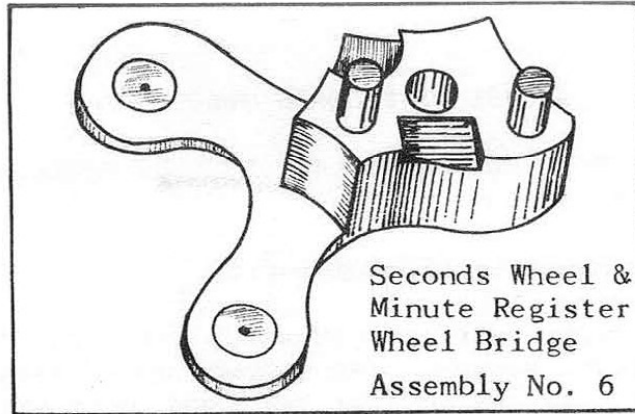

OILING

The pivots in the jewels in this bridge should be oiled as you would properly oil a train pivot in a watch.

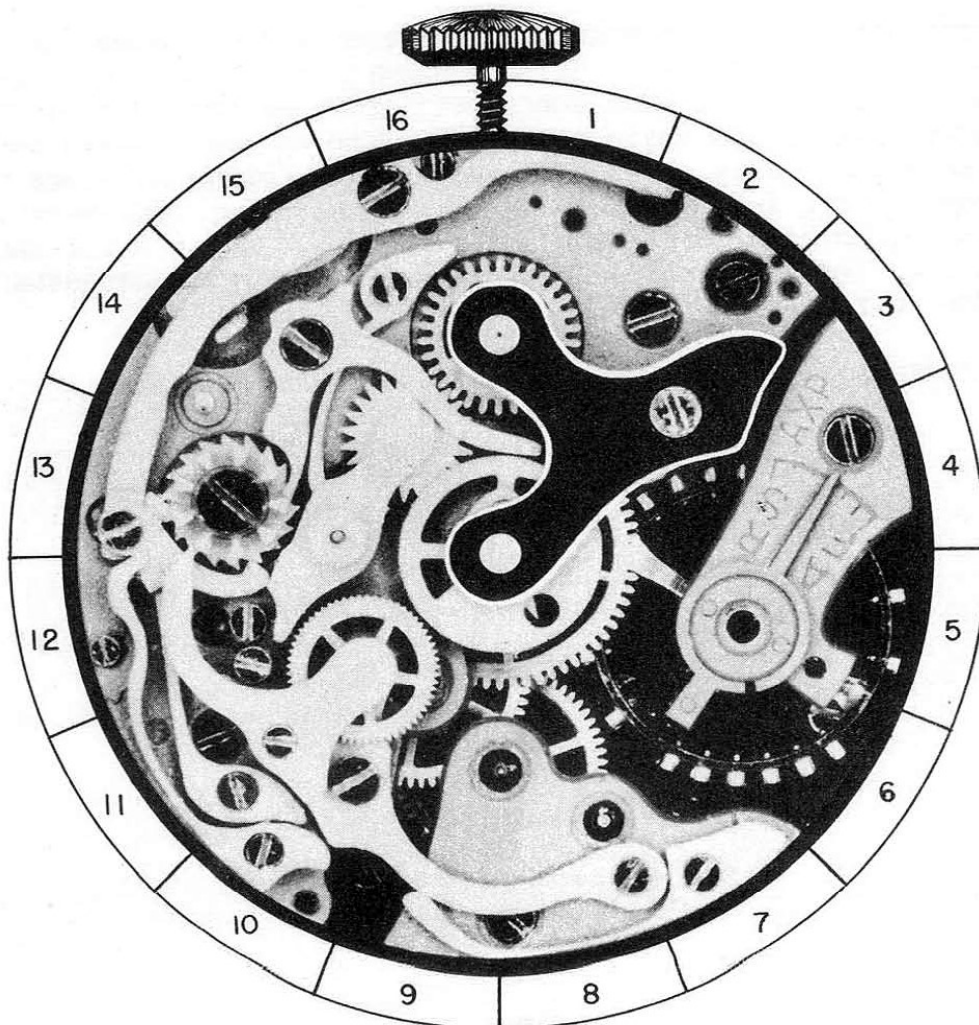

6-A

PART NO. 7

A. DISASSEMBLY PROCEDURE OF SECONDS WHEEL:

TO REMOVE THIS WHEEL SIMPLY LIFT SECONDS WHEEL POST OUT OF HOLLOW CENTER PINION.

B. ASSEMBLY PROCEDURE OF SECONDS WHEEL:

THE SECONDS WHEEL IS PLACED IN WATCH WITH LONG POST "A" DOWN IN HOLLOW CENTER PINION. THE SECONDS WHEEL BRAKE LEVER SHOULD BE MOVED OUT SLIGHTLY SO THAT THE WHEEL DOES NOT SET ON TOP OF BRAKE LEVER.

C. HAZARDS IN ASSEMBLY OF SECONDS WHEEL:

FAILURE TO MOVE THE SECONDS WHEEL BRAKE FROM UNDER SECONDS WHEEL MAY RESULT IN WHEEL BEING BENT WHEN BRIDGE IS REPLACED.

D. FUNCTIONS OF SECONDS WHEEL:

THE FUNCTION OF THIS WHEEL IS TO REGISTER THE SECONDS ON THE DIAL BY MEANS OF A HAND BEING ATTACHED TO THE SECONDS WHEEL POST. ALSO THE SECONDS WHEEL MUST MOVE THE MINUTE REGISTER WHEEL FORWARD ONE TOOTH EVERY TIME SECONDS WHEEL MAKES ONE REVOLUTION. THIS IS DONE BY A DART TOOTH BEING ATTACHED TO SECOND WHEEL THAT MESHES WITH TEETH ON INTERMITTENT WHEEL. THE INTERMITTENT WHEEL MOVES THE MINUTE REGISTER WHEEL ONE TOOTH. THE SECONDS WHEEL HAS A HEART ON IT FOR RETURNING HAND TO ZERO.

REFERENCE: SECONDS WHEEL DART TOOTH IS ASSEMBLY 7-C
SECONDS WHEEL HEART IS ASSEMBLY 7-B
INTERMITTENT WHEEL IS ASSEMBLY 12-A

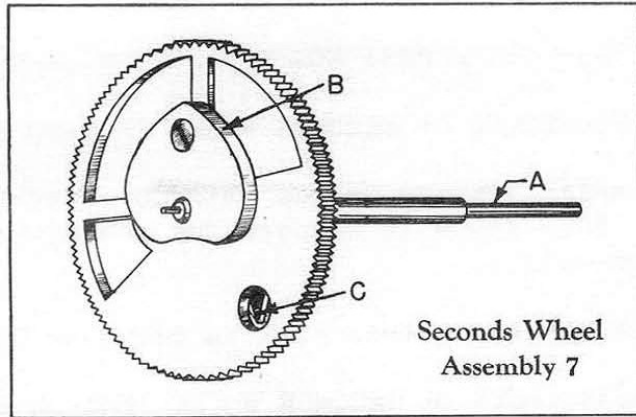

OILING

The top pivot of seconds wheel should be oiled after bridge for this wheel is placed in watch.

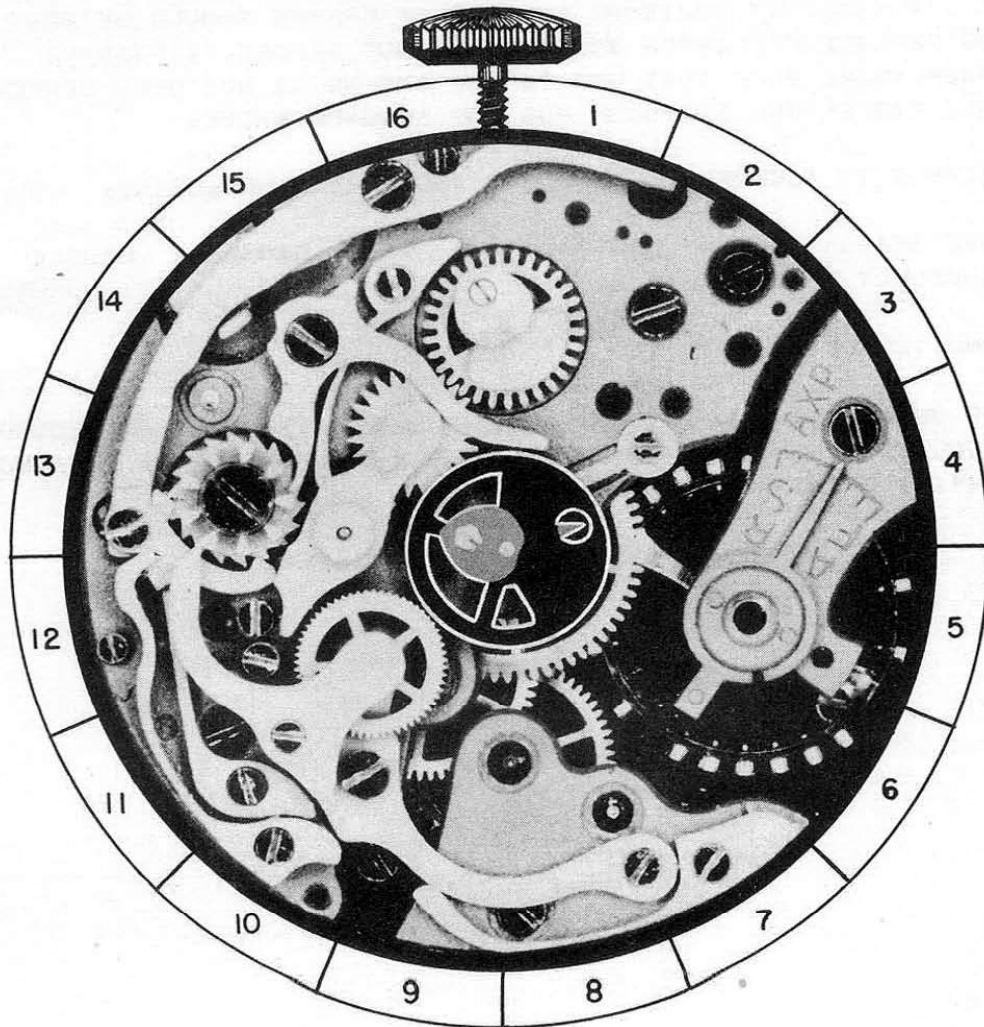

PART NO. 8

A. DISASSEMBLY PROCEDURE OF SECONDS WHEEL TENSION SPRING:

THE SECONDS WHEEL TENSION SPRING IS HELD IN PLACE BY FILLISTER SCREW FS-2. WHEN SCREW IS REMOVED THE SPRING MAY BE LIFTED FROM PLATE OF WATCH.

(THE SHAPE OF SCREW FOR THIS PART IS SHOWN AT BOTTOM OF PAGE)

B HAZARDS IN DISASSEMBLY OF SECONDS WHEEL TENSION SPRING:

THE TENSION SPRING SHOULD BE HANDLED WITH CARE AS THIS SPRING IS VERY DELICATE AND MAY EASILY BE DAMAGED.

C. ASSEMBLY PROCEDURE OF SECONDS WHEEL TENSION SPRING:

THE TENSION SPRING IS PLACED ON PLATE WITH HOLE IN SPRING OVER PROPER HOLE IN PLATE. MAKE SURE SPRING IS RIGHT SIDE UP. THE HIGHLY POLISHED END "A" OF SPRING SHOULD BE UP. NOW REPLACE FILLISTER SCREW FS-2, BUT BEFORE TIGHTENING SCREW, MAKE SURE THAT END "A" OF SPRING IS NOT OVER CENTER HOLE FAR ENOUGH TO TOUCH POST OF SECONDS WHEEL.

D. HAZARDS IN ASSEMBLY OF SECONDS WHEEL TENSION SPRING:

THIS SPRING IS VERY DELICATE AND EASILY DAMAGED. HANDLE CAREFULLY WHEN REPLACING.

E. FUNCTION OF SECONDS WHEEL TENSION SPRING:

THE SECONDS WHEEL TENSION SPRING HOLDS A TENSION ON SECONDS WHEEL TO KEEP IT TURNING WITH A SMOOTH EVEN ACTION WITH NO JUMPING OR JERKING.

REFERENCE: SECONDS WHEEL IS ASSEMBLY 7

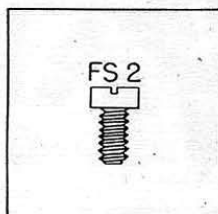

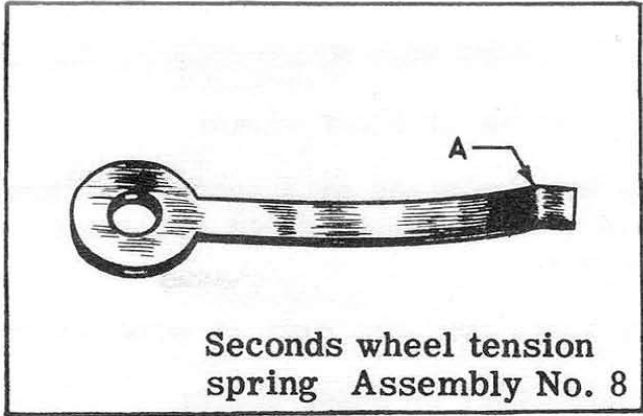

OILING
Seconds wheel tension spring should not be oiled.

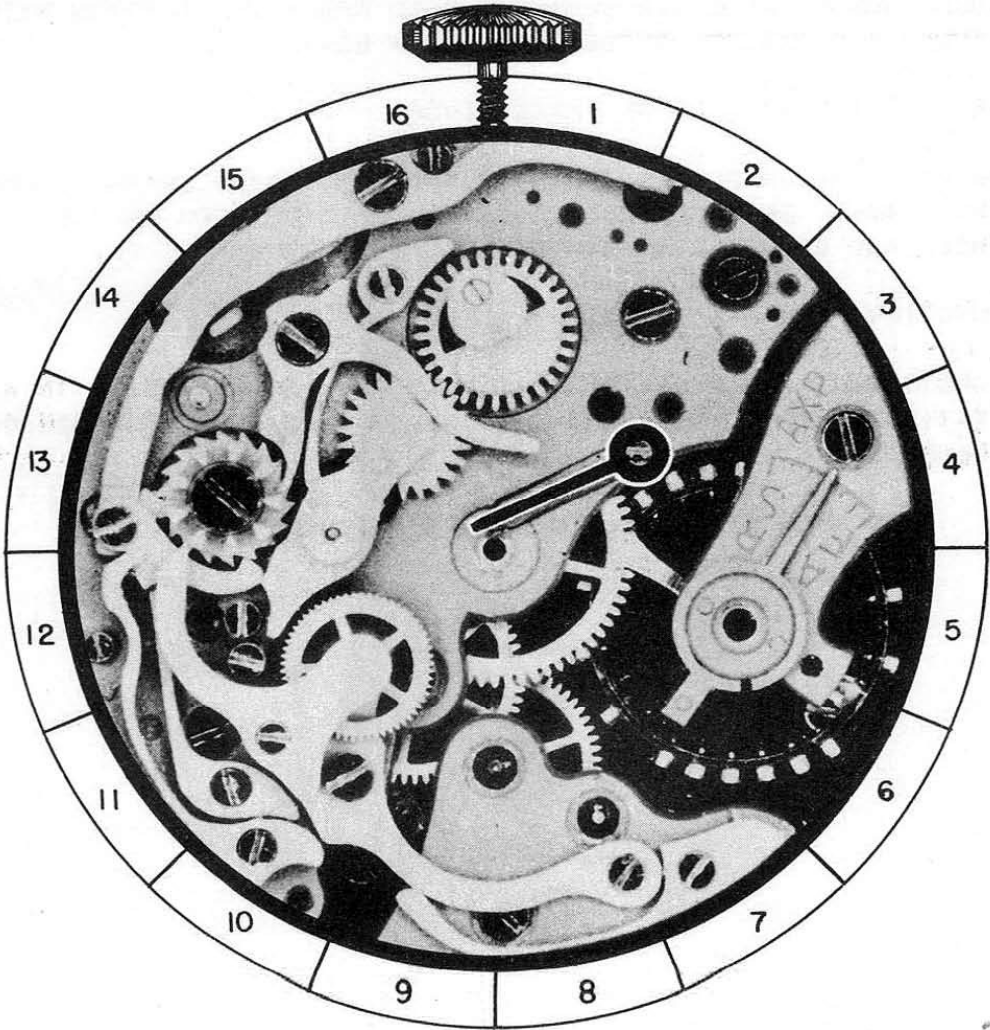

8-A

PART NO. 9

A. DISASSEMBLY PROCEDURE OF BRAKE LEVER:

THIS LEVER IS HELD IN PLACE BY A SHOULDERED SCREW SS-1 AND PIVOTS ON THIS SCREW. REMOVE SCREW AND BRAKE LEVER MAY BE LIFTED FROM PLATE.

(THE SHAPE OF SCREW FOR THIS PART IS SHOWN AT BOTTOM OF PAGE)

B. HAZARDS IN DISASSEMBLY OF BRAKE LEVER:

HOLD FINGER ON BRAKE LEVER WHEN REMOVING SCREW SO THAT LEVER OR SCREW DOES NOT SHOOT AWAY.

C. ASSEMBLY PROCEDURE OF BRAKE LEVER:

PLACE BRAKE ON PLATE WITH PIN "C" UP. SLIDE BRAKE ON PLATE TO ITS PROPER POSITION WITH END "A" OF BRAKE BETWEEN CASTLE WHEEL AND BRAKE LEVER SPRING. HOLD BRAKE IN POSITION WITH FINGER AND REPLACE SHOULDERED SCREW SS-1.

D. HAZARDS IN ASSEMBLY OF BRAKE LEVER:

DO NOT SCRATCH PLATES OR LEVER WHEN REPLACING BRAKE TO PROPER PLACE. BE SURE END "A" OF BRAKE IS BETWEEN CASTLE WHEEL AND BRAKE LEVER SPRING BEFORE REPLACING SCREW.

E. FUNCTION OF BRAKE LEVER:

FUNCTION OF BRAKE LEVER IS TO HOLD THE SECONDS WHEEL IN A STATIONARY POSITION WHEN IT IS DISENGAGED FROM CHRONOGRAPH MECHANISM.

REFERENCE: CASTLE WHEEL IS ASSEMBLY 22

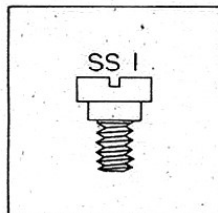

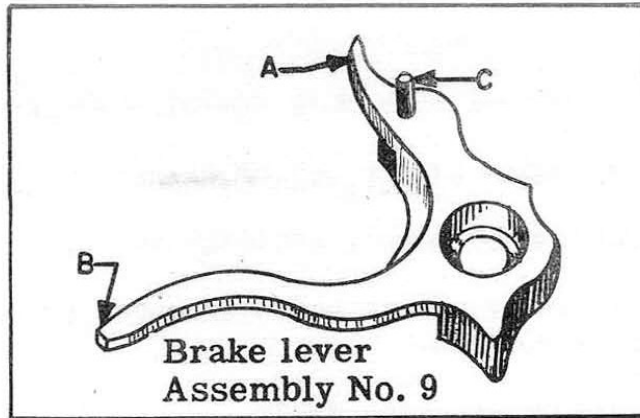

Brake lever
Assembly No. 9

OILING

The shouldered screw SS-1 that brake lever pivots on should be slightly moistened with oil.

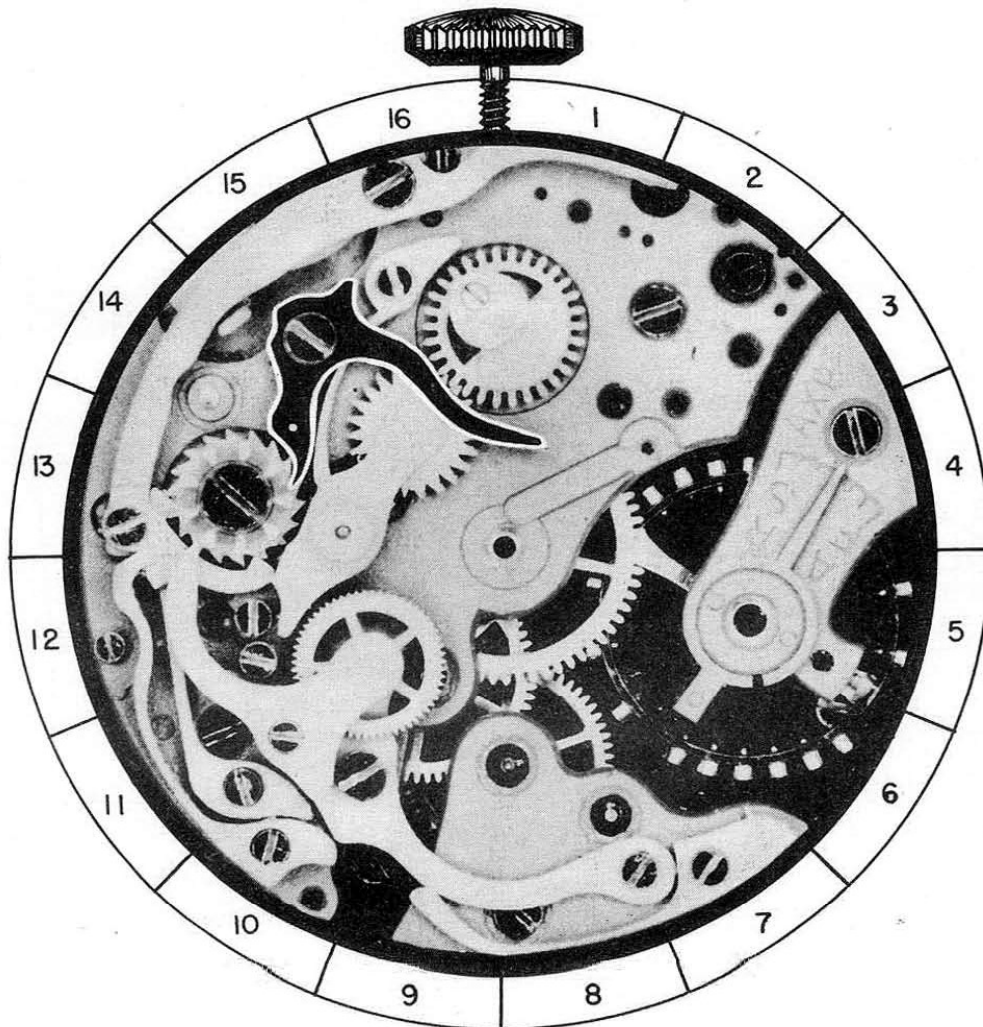

9-A

PART NO. 10

A. DISASSEMBLY PROCEDURE OF MINUTE REGISTER WHEEL:

THIS WHEEL IS SIMPLY LIFTED OUT OF PLACE.

B. ASSEMBLY PROCEDURE OF MINUTE REGISTER WHEEL:

THE LONG POST "A" OF MINUTE REGISTER WHEEL SHOULD BE PLACED DOWN IN HOLE IN BUSHING.

C. FUNCTION OF MINUTE REGISTER WHEEL:

THE FUNCTION OF THIS WHEEL IS TO RECORD THE MINUTES ON THE DIAL; THIS IS DONE BY A HAND BEING ATTACHED TO THE POST "A" ON THE MINUTE REGISTER WHEEL PINION. THIS WHEEL IS ALSO EQUIPPED WITH A HEART FOR RETURNING THE HAND TO ZERO.

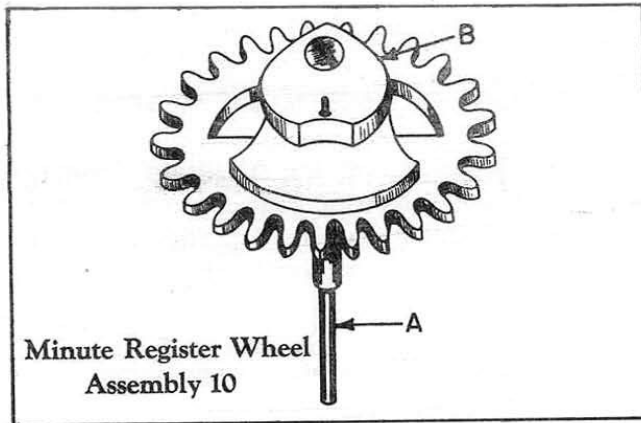

OILING

The top and bottom pivots of minute register wheel should be oiled after bridge for this wheel is placed in watch. Oil these pivots as you would normally oil a train pivot in a watch.

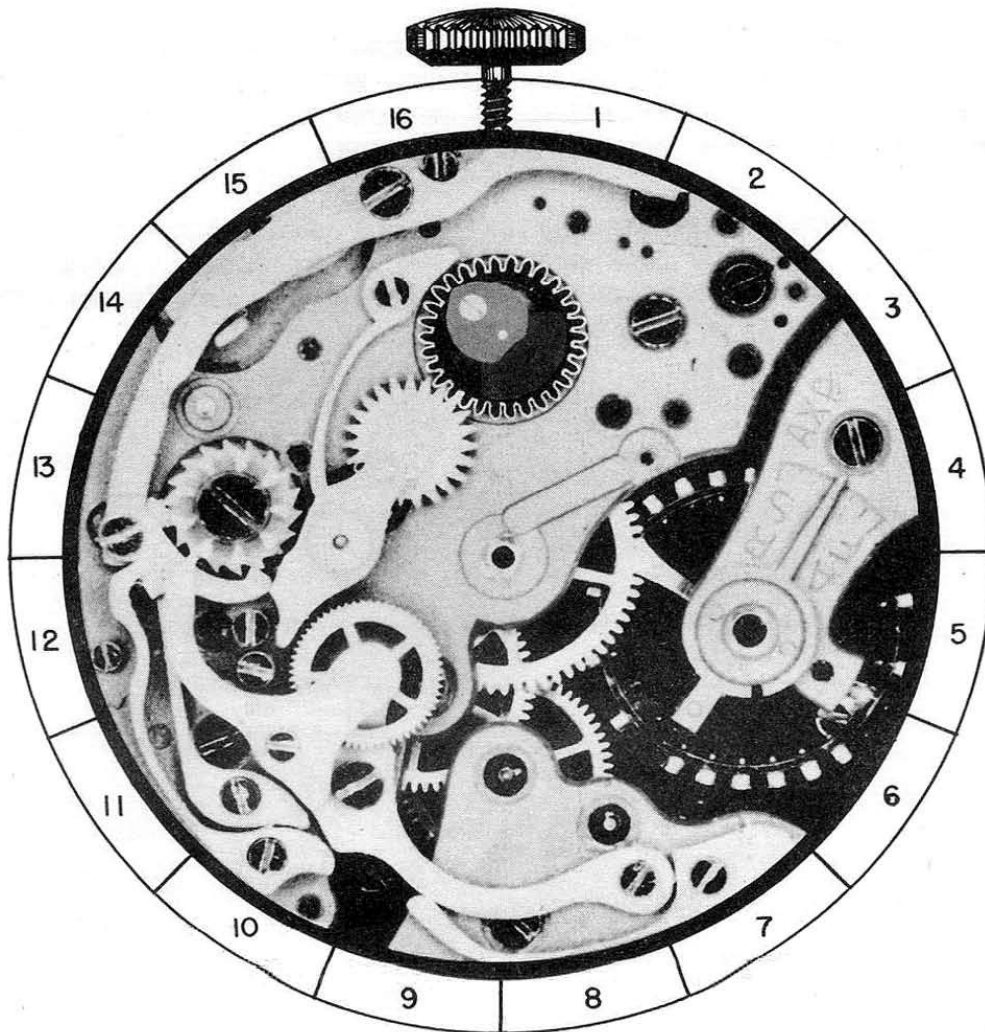

10-A

PART NO. 11

A. DISASSEMBLY PROCEDURE OF INTERMITTENT LEVER SPRING:

THIS SPRING IS HELD IN PLACE BY BEVELED COUNTERSINK SCREW BS-3 AND STEADY PIN. REMOVE SCREW AND LOOSEN SPRING FROM PLATE BY SLIDING A THIN BLADE SCREWDRIVER BETWEEN PLATE AND SPRING. WHEN STEADY PIN IS FREE IN PLATE, SPRING MAY BE LIFTED FROM MOVEMENT.

(THE SHAPE OF SCREW FOR THIS PART IS SHOWN AT BOTTOM OF PAGE)

B. ASSEMBLY PROCEDURE OF INTERMITTENT LEVER SPRING:

PLACE SPRING IN PLACE ON PLATE WITH STEADY PIN IN PROPER HOLE. END "A" OF SPRING SHOULD BE ON TOP OF PART "B" ON INTERMITTENT LEVER. WITH SPRING IN THIS POSITION, PRESS DOWN IN PLACE AND REPLACE BEVELED COUNTERSINK SCREW BS-3.

C. FUNCTION OF INTERMITTENT LEVER SPRING:

THIS SPRING HOLDS A TENSION ON INTERMITTENT LEVER TO ENGAGE THE INTERMITTENT WHEEL WITH SECONDS WHEEL DART TOOTH. IT ALSO HOLDS THE INTERMITTENT LEVER DOWN ON POST, PREVENTING IT FROM RIDING UP AND COMING OUT OF PLACE.

REFERENCE: INTERMITTENT LEVER IS ASSEMBLY 12
INTERMITTENT WHEEL IS ASSEMBLY 12-A
SECONDS WHEEL DART TOOTH IS ASSEMBLY 7-C

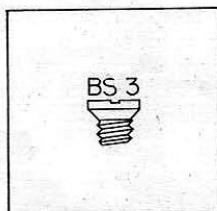

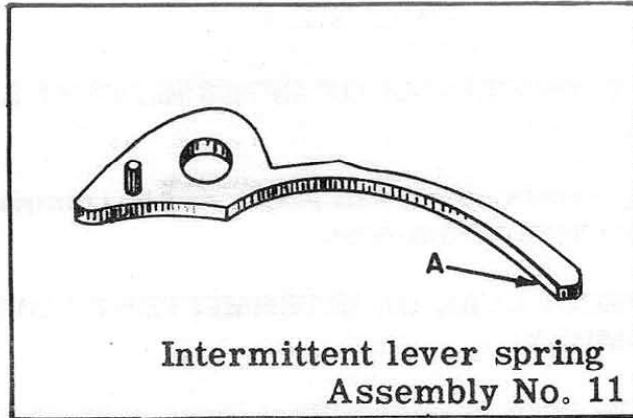

OILING

The end "A" of intermittent lever spring should be slightly moistened with oil at point it contacts intermittent lever.

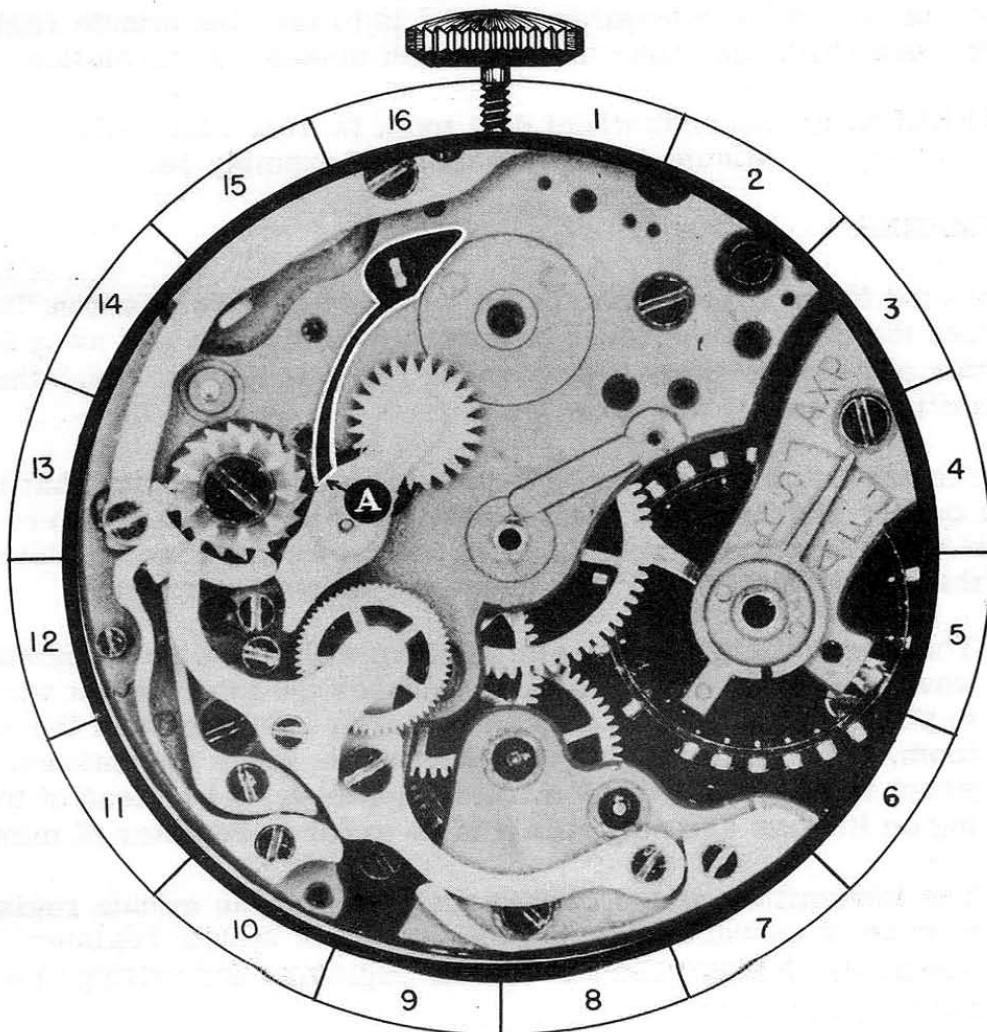

11-A

PART NO. 12

A. DISASSEMBLY PROCEDURE OF INTERMITTENT LEVER AND WHEEL ASSEMBLY:

This assembly pivots on post in plate, and to remove it, simply lift intermittent lever from post.

B. ASSEMBLY PROCEDURE OF INTERMITTENT LEVER AND WHEEL ASSEMBLY:

Place hole in bushing in intermittent lever over proper post in plate as shown in photograph. Now push assembly down to proper place. Assembly should pivot freely on post.

C. FUNCTION OF INTERMITTENT LEVER AND WHEEL ASSEMBLY:

The function of the intermittent lever is to engage and disengage the intermittent wheel with the seconds wheel dart tooth.

The function of the intermittent wheel is to turn the minute register wheel one tooth each time the dart tooth makes one revolution.

REFERENCE: Seconds wheel dart tooth is Assembly 7-C.
Minute register wheel is Assembly 10.

REMARKS:

When the flyback lever returns the wheels to a zero position, it forces the intermittent lever to move intermittent wheel away from center of watch, making it impossible for dart tooth to touch the intermittent wheel at this time.

The intermittent wheel should be carefully checked to see that it has proper endshake and spins freely in the intermittent lever. This wheel must, of necessity, spin freely, as any excess friction on the intermittent wheel may cause the following errors:

1. The intermittent wheel teeth meshing with the minute register wheel teeth which are stationary causes the intermittent wheel to pivot and turn on its axis as it moves to engage with the dart tooth. When engaging with the dart tooth, if the intermittent wheel is binding, it turns minute register wheel instead of turning on its axis and may result in an error in register of minutes.
2. The intermittent wheel binding may prevent the minute register pawl from correctly spacing the turning of minute register wheel, which may result in minute register hand setting at an incorrect position.

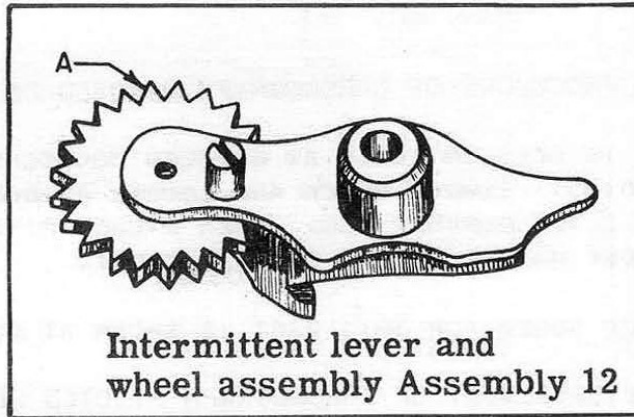

OILING

The stud that intermittent lever pivots on should be slightly moistened with oil. The intermittent wheel should not be oiled.

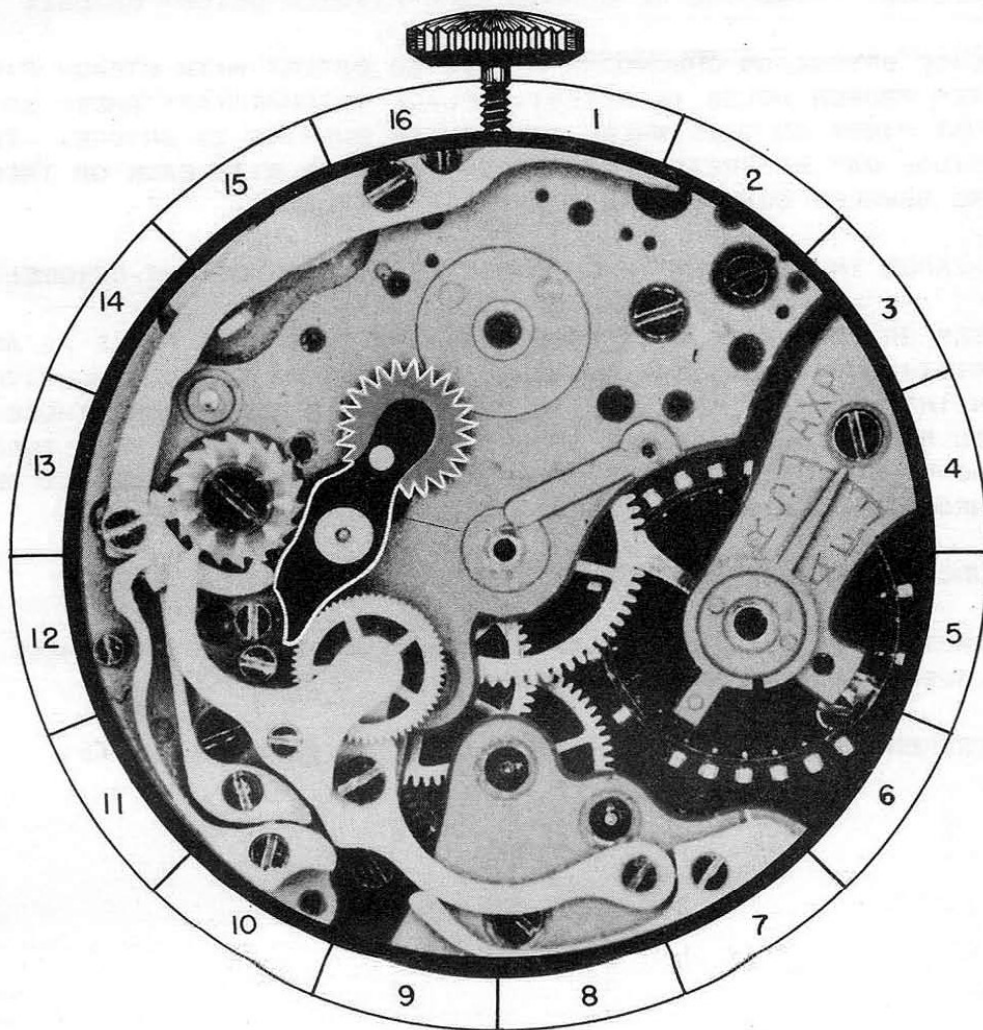

12-A

PART NO. 13

A. DISASSEMBLY PROCEDURE OF CHRONOGRAPH PIVOTED DETENT BRIDGE:

THIS BRIDGE IS HELD IN PLACE BY BEVELED COUNTERSINK SCREW BS-4 AND STEADY PINS. REMOVE SCREW AND LOOSEN BRIDGE FROM DETENT WITH A THIN BLADE SCREWDRIVER. WHEN STEADY PINS ARE FREE OF DETENT, BRIDGE MAY BE LIFTED FROM MOVEMENT.

(THE SHAPE OF SCREW FOR THIS PART IS SHOWN AT BOTTOM OF PAGE)

B. HAZARDS IN DISASSEMBLY OF CHRONOGRAPH PIVOTED DETENT BRIDGE:

WHEN USING A SCREWDRIVER TO LOOSEN BRIDGE FROM DETENT, CARE SHOULD BE TAKEN TO KEEP BRIDGE LEVEL AS ANY TWISTING MAY DAMAGE THE PIVOTS ON INTERMEDIARY WHEEL OR BURR THE BUSHINGS IN BRIDGE OR PIVOTED DETENT. THE SCREWDRIVER SHOULD BE CAREFULLY USED SO AS NOT TO MAR CHRONOGRAPH PIVOTED DETENT OR BRIDGE.

C. ASSEMBLY PROCEDURE OF CHRONOGRAPH PIVOTED DETENT BRIDGE:

PLACE BRIDGE ON CHRONOGRAPH PIVOTED DETENT WITH STEADY PINS OVER PROPER HOLES IN DETENT. PLACE INTERMEDIARY WHEEL SO THAT PIVOT ON THIS WHEEL WILL ENTER BUSHING IN BRIDGE. THE BRIDGE MAY BE PRESSED TO PROPER POSITION WITH BACK OF TWEEZERS AND BEVELED COUNTERSINK SCREW BS-4 REPLACED.

D. HAZARDS IN ASSEMBLY OF CHRONOGRAPH PIVOTED DETENT BRIDGE:

KEEP BRIDGE LEVEL WHEN PRESSING DOWN TO PROPER PLACE AS ANY TWISTING MAY BURR THE BUSHING IN BRIDGE OR DAMAGE THE PIVOT ON INTERMEDIARY WHEEL. THE BRIDGE AND DETENT WHERE THESE TWO PARTS COME TOGETHER SHOULD BE CHECKED TO SEE THAT THERE ARE NO BURRS THAT WOULD PREVENT BRIDGE SETTING PROPERLY ON CHRONOGRAPH PIVOTED DETENT.

E. FUNCTION OF CHRONOGRAPH PIVOTED DETENT BRIDGE:

FUNCTION OF THIS BRIDGE IS TO HOLD THE INTERMEDIARY WHEEL IN PLACE SO IT CAN FUNCTION PROPERLY.

REFERENCE: CHRONOGRAPH PIVOTED DETENT IS ASSEMBLY 15

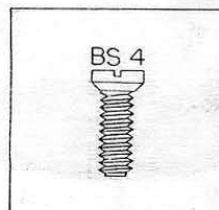

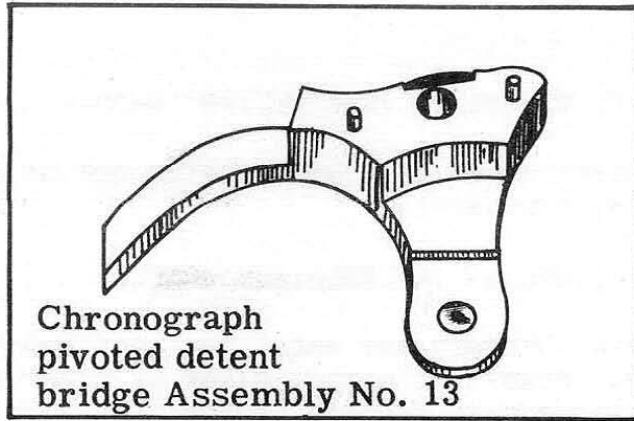

OILING

The pivot in bushing in chronograph pivoted detent bridge, should be oiled as you would properly oil a train pivot in a watch.

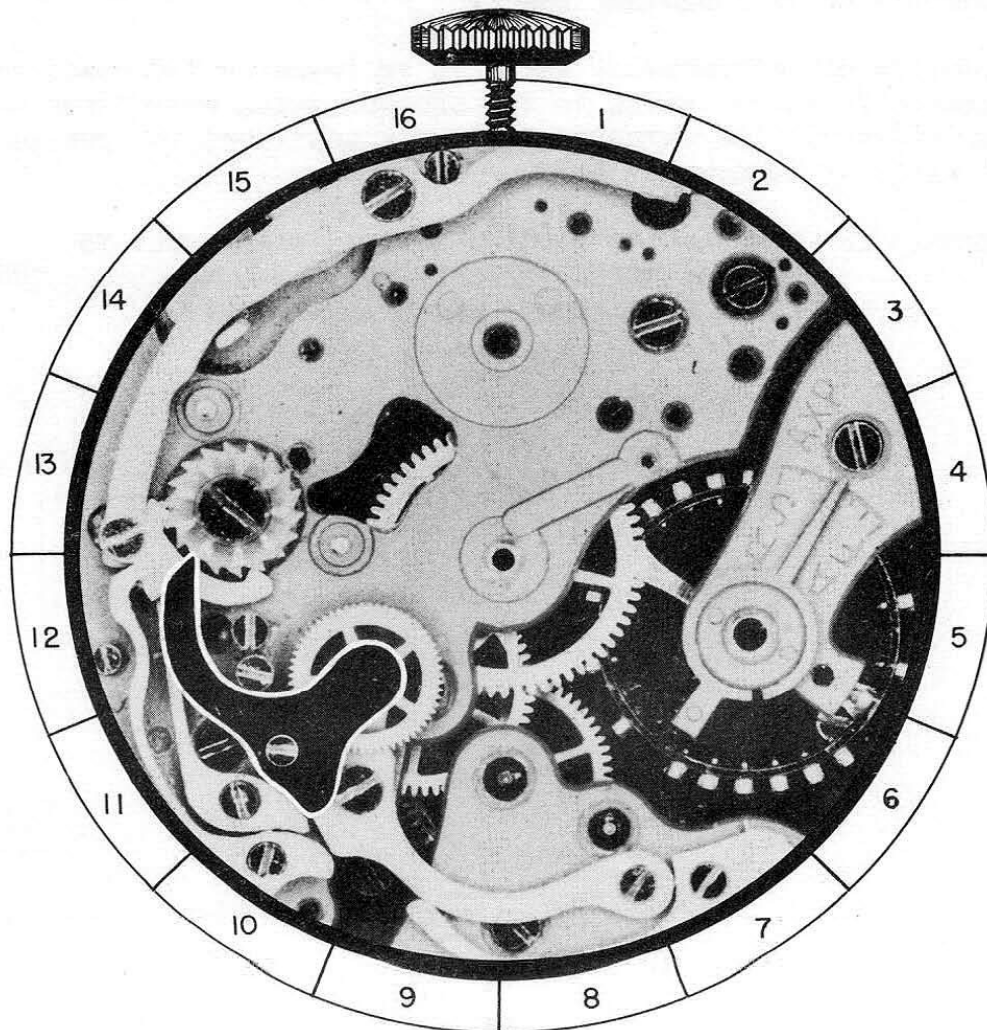

13-A

PART NO. 14

A. DISASSEMBLY PROCEDURE OF INTERMEDIARY WHEEL:

THE INTERMEDIARY WHEEL IS SIMPLY LIFTED OUT OF BUSHING IN CHRONOGRAPH PIVOTED DETENT.

B. ASSEMBLY PROCEDURE OF INTERMEDIARY WHEEL:

WHEN REPLACING INTERMEDIARY WHEEL THE LONG END "A" OF STAFF SHOULD BE UP. PLACE THE BOTTOM PIVOT OF STAFF IN HOLE IN BUSHING OF CHRONOGRAPH PIVOTED DETENT.

C. HAZARDS IN ASSEMBLY OF INTERMEDIARY WHEEL:

THE PIVOT HOLE IN BUSHING OF CHRONOGRAPH PIVOTED DETENT SHOULD BE CAREFULLY EXAMINED BEFORE REPLACING INTERMEDIARY WHEEL. ANY IMPERFECTION HERE WILL AFFECT THE TIMEKEEPING OF THE WATCH AND HINDER PROPER OPERATION OF CHRONOGRAPH.

D. FUNCTION OF INTERMEDIARY WHEEL:

FUNCTION OF INTERMEDIARY WHEEL IS TO TRANSFER THE POWER FROM WHEEL OVER FOURTH WHEEL TO THE SECONDS WHEEL WHEN THESE WHEELS ARE ENGAGED. THE INTERMEDIARY WHEEL CONTINUES TO TURN AS LONG AS WATCH IS RUNNING.

REFERENCE: CHRONOGRAPH PIVOTED DETENT IS ASSEMBLY 16
SECONDS WHEEL IS ASSEMBLY 7
WHEEL OVER FOURTH WHEEL IS ASSEMBLY 1

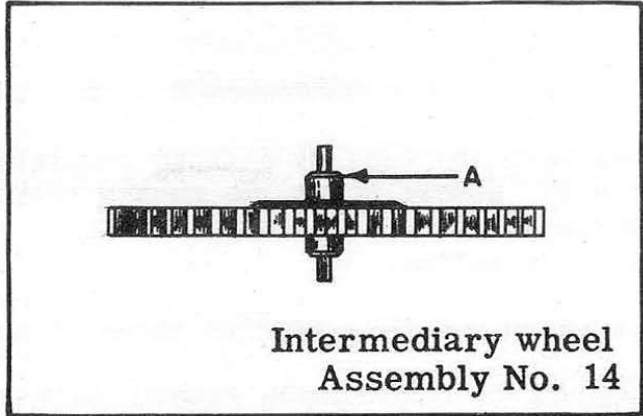

OILING

The bottom pivot of intermediary wheel should be oiled before placing pivot in chronograph pivoted detent. The top pivot should be oiled after bridge for this wheel is placed in watch.

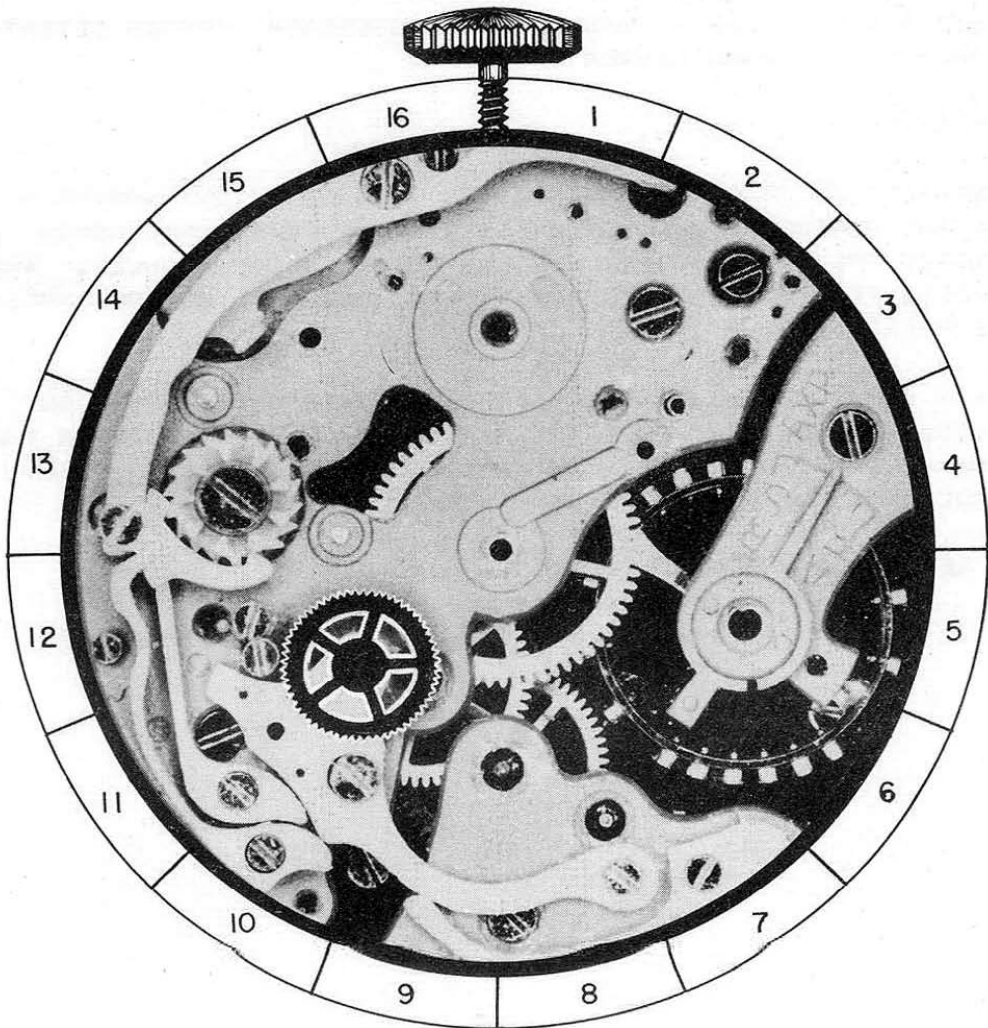

14-A

PART NO. 15

A. DISASSEMBLY PROCEDURE OF CHRONOGRAPH PIVOTED DETENT SPRING:

THIS SPRING IS HELD IN PLACE BY BEVELED COUNTERSINK SCREW BS-5 AND A STEADY PIN. REMOVE SCREW AND LOOSEN SPRING WITH A THIN BLADE SCREWDRIVER. WHEN STEADY PIN IS FREE IN PLATE, SPRING MAY BE LIFTED FROM WATCH.

(THE SHAPE OF SCREW FOR THIS PART IS SHOWN AT BOTTOM OF PAGE)

B. ASSEMBLY PROCEDURE OF CHRONOGRAPH PIVOTED DETENT SPRING:

PLACE SPRING IN PLACE ON PLATE WITH STEADY PIN IN PROPER HOLE. BEFORE PRESSING SPRING DOWN TO PLACE, CHECK TO SEE THAT END "A" OF SPRING IS NOT ON TOP OF DETENT LEVER. WHEN SPRING IS IN PROPER PLACE PRESS DOWN AND REPLACE BEVELED COUNTERSINK SCREW BS-5.

C. FUNCTION OF CHRONOGRAPH PIVOTED DETENT SPRING:

THIS SPRING HOLDS A TENSION ON CHRONOGRAPH PIVOTED DETENT, FORCING IT TOWARD CENTER OF WATCH.

D. REMARKS:

THE TENSION THAT THE CHRONOGRAPH PIVOTED DETENT SPRING HOLDS ON THE CHRONOGRAPH PIVOTED DETENT MUST BE STRONG ENOUGH TO ENGAGE THE INTERMEDIARY WHEEL WITH THE SECONDS WHEEL. ANY EXCESS TENSION TENDS TO MAKE THE CHRONOGRAPH BUTTON HARDER TO PUSH.

THIS SPRING IS ADJUSTABLE AS TO THE TENSION IT HOLDS ON DETENT LEVER, BY THE STEADY PIN BEING SOMEWHAT SMALLER THAN THE HOLE IN THE PLATE. THIS PERMITS THE SPRING TO PIVOT UNDER HEAD OF BEVELED COUNTERSINK SCREW BS-5.

REFERENCE: SECONDS WHEEL IS ASSEMBLY 7.
INTERMEDIARY WHEEL IS ASSEMBLY 14
CHRONOGRAPH PIVOTED DETENT IS ASSEMBLY 16.

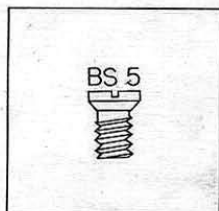

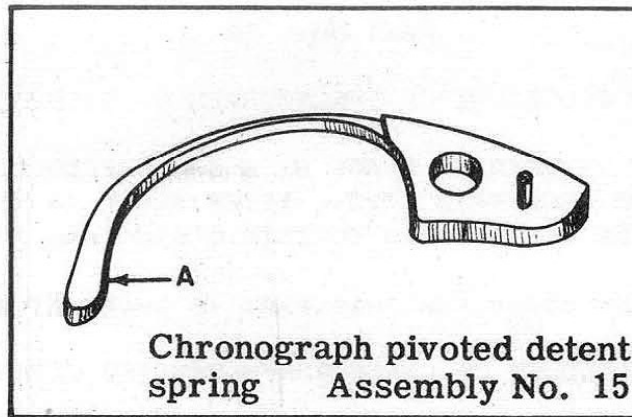

OILING

End "A" of chronograph pivoted detent spring that contacts chronograph pivoted detent should be slightly moistened with oil.

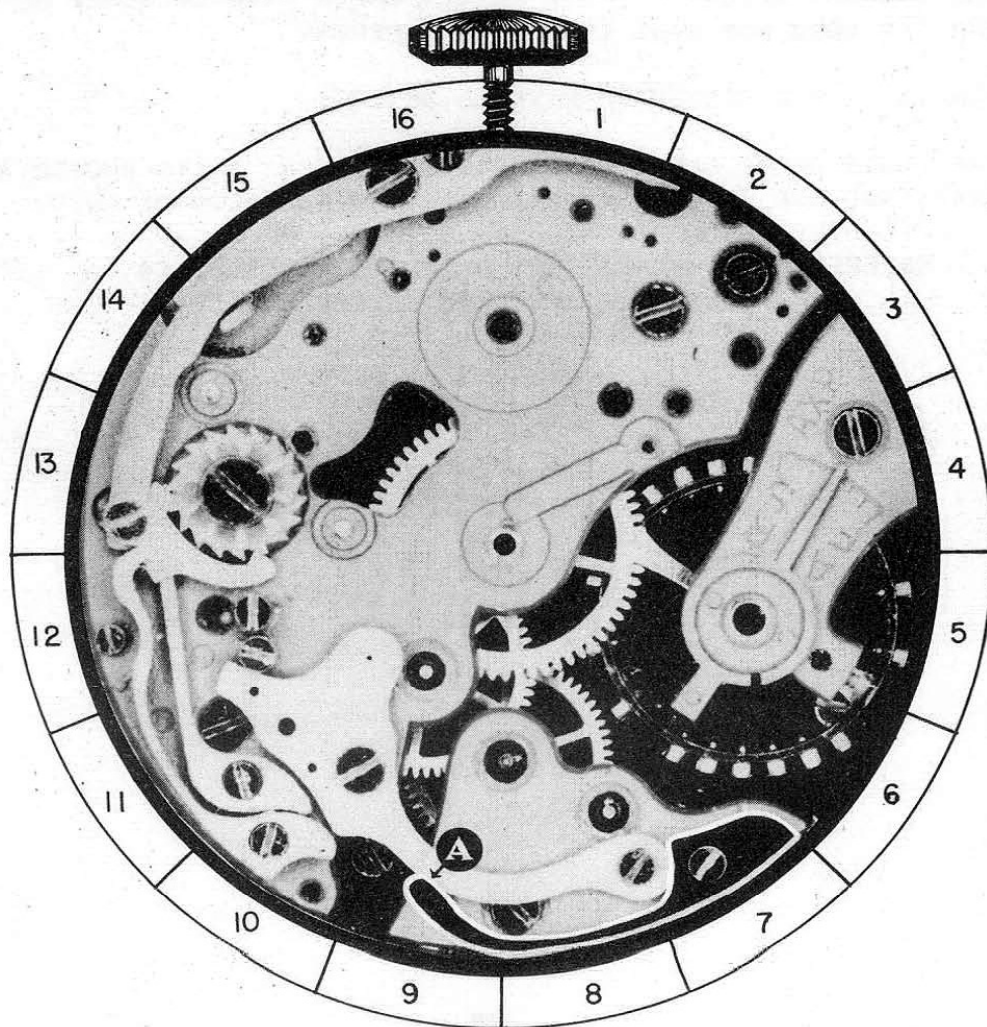

15-A

PART NO. 16

A. DISASSEMBLY PROCEDURE OF CHRONOGRAPH PIVOTED DETENT:

THIS DETENT IS HELD IN PLACE BY A SHOULDERED SCREW SS-2 AND PIVOTS ON AN ECCENTRIC STUD. AFTER SCREW IS REMOVED, THE DETENT MAY BE LIFTED FROM ECCENTRIC STUD AND FREE OF PLATE.

(THE SHAPE OF SCREW FOR THIS PART IS SHOWN AT BOTTOM OF PAGE)

B. ASSEMBLY PROCEDURE OF CHRONOGRAPH PIVOTED DETENT:

PLACE DETENT ON PLATE WITH HOLE IN END OF DETENT OVER ECCENTRIC STUD AS DETENT PIVOTS ON THIS STUD. WHEN DETENT IS IN PROPER PLACE, SHOULDERED SCREW SS-2 MAY BE REPLACED. THE DETENT MUST MOVE FREELY UNDER THE HEAD OF THIS SCREW.

C. HAZARDS IN ASSEMBLY OF CHRONOGRAPH PIVOTED DETENT:

AFTER REPLACING DETENT, IT SHOULD BE CHECKED TO SEE THAT IT HAS ENOUGH FREEDOM TO MOVE FREELY UNDER HEAD OF SCREW SS-2 AND YET DOES NOT HAVE EXCESSIVE FREEDOM.

D. FUNCTION OF CHRONOGRAPH PIVOTED DETENT:

THE FUNCTION OF CHRONOGRAPH PIVOTED DETENT IS TO ENGAGE AND DISENGAGE THE INTERMEDIARY WHEEL WITH THE SECONDS WHEEL.

REFERENCE: INTERMEDIARY WHEEL IS ASSEMBLY 14
SECONDS WHEEL IS ASSEMBLY 7

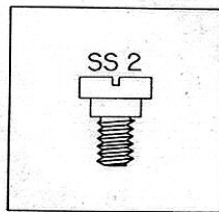

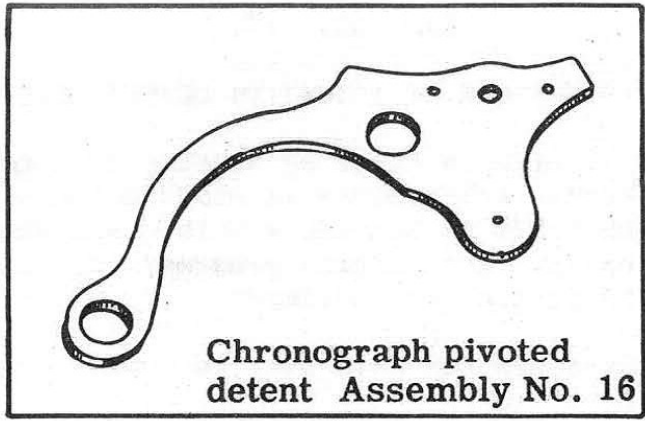

OILING

The eccentric stud that chronograph pivoted detent pivots on should be slightly moistened with oil.

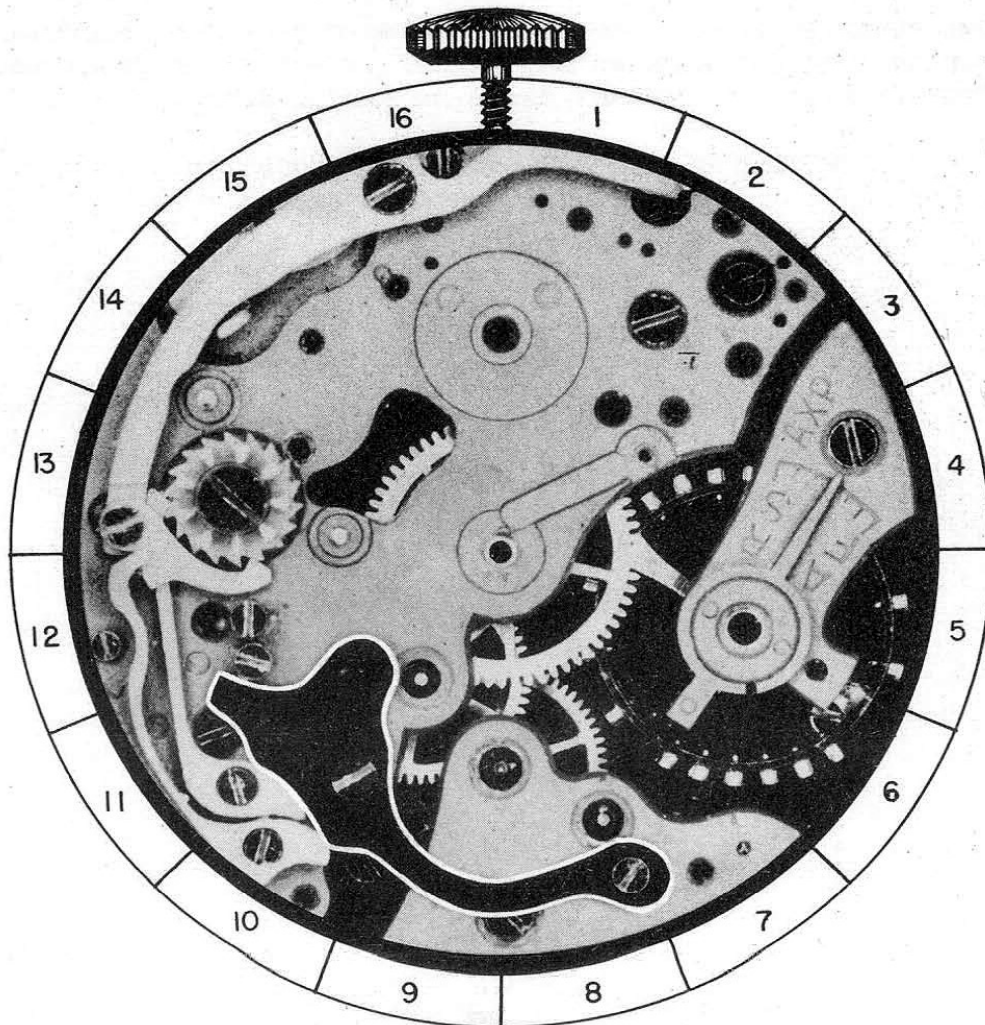

PART NO. 17

A. DISASSEMBLY PROCEDURE OF ACTUATING DETENT LEVER SPRING:

THIS SPRING IS HELD IN PLACE BY BEVELED COUNTERSINK SCREW BS-6 AND STEADY PINS. AFTER SCREW IS REMOVED THE SPRING MAY BE LOOSENED FROM PLATE BY SLIDING A THIN BLADE SCREWDRIVER BETWEEN PLATE AND SPRING. WHEN STEADY PINS ARE FREE IN PLATE, THE SPRING MAY BE LIFTED FROM MOVEMENT.

(THE SHAPE OF SCREW FOR THIS PART IS SHOWN AT BOTTOM OF PAGE)

B. ASSEMBLY PROCEDURE OF ACTUATING DETENT LEVER SPRING:

PLACE SPRING ON PLATE WITH STEADY PINS OVER PROPER HOLES IN PLATE. END "A" OF SPRING SHOULD BE ON TOP OF JOINT HOOK. WITH SPRING IN THIS POSITION, PRESS DOWN TO PROPER PLACE AND REPLACE BEVELED COUNTERSINK SCREW BS-6.

C. FUNCTION OF ACTUATING DETENT LEVER SPRING:

THE FUNCTION OF THIS SPRING IS TO MOVE THE JOINT HOOK IN TOWARD THE CENTER OF WATCH; ALSO, IT HOLDS THE JOINT HOOK IN CONTACT WITH THE RATCHET TEETH ON CASTLE WHEEL.

REFERENCE: JOINT HOOK IS ASSEMBLY 18
CASTLE WHEEL IS ASSEMBLY 22

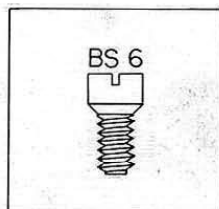

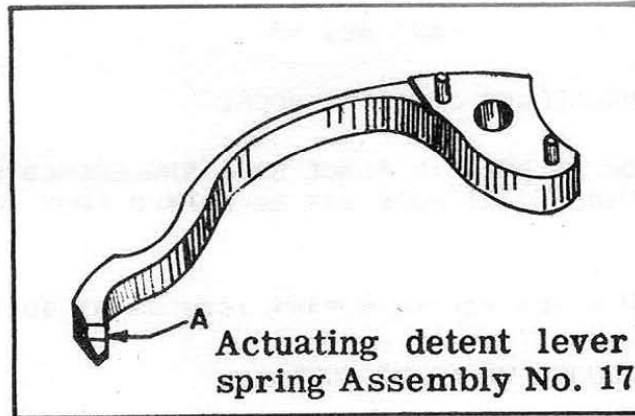

OILING

End "A" of actuating detent lever spring where it contacts joint hook should be slightly moistened with oil.

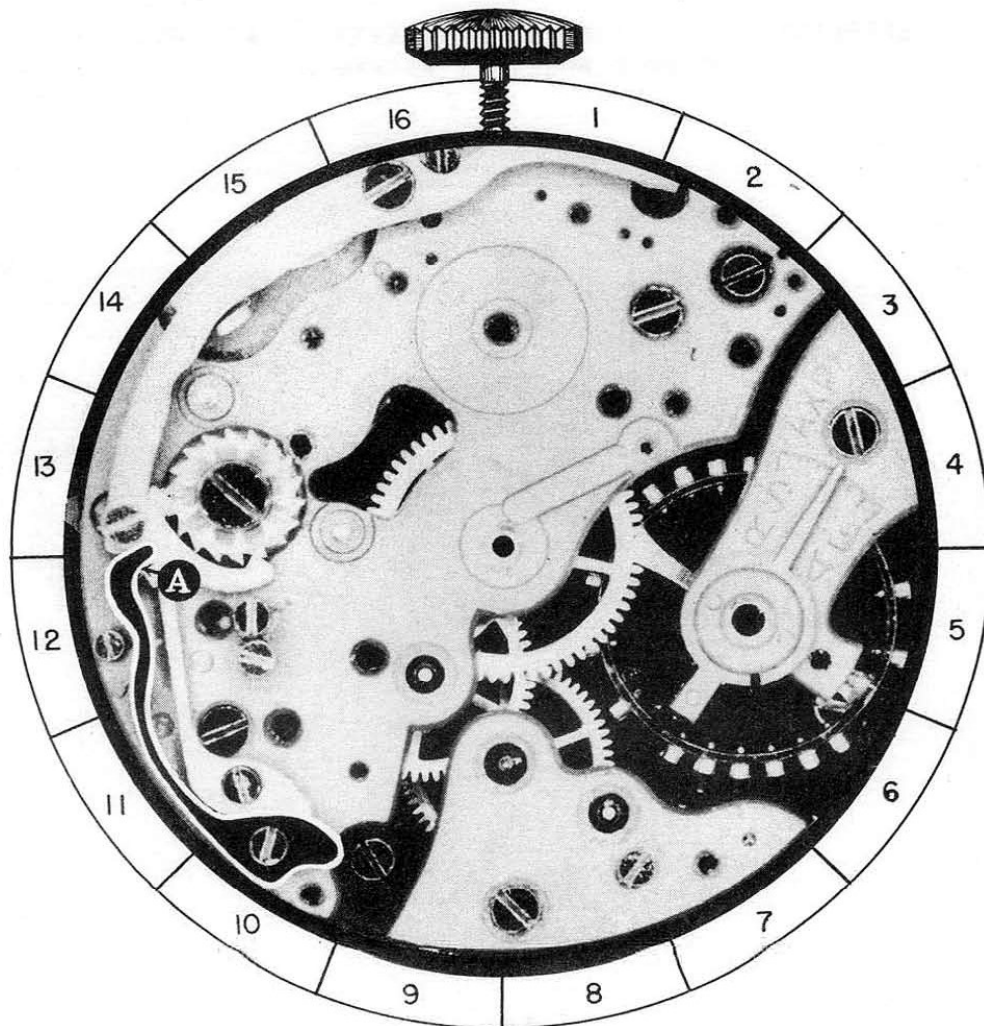

17-A

PART NO. 18

A. DISASSEMBLY PROCEDURE OF JOINT HOOK:

THE JOINT HOOK IS HELD IN PLACE BY A SHOULDERED SCREW SS-3. REMOVE SCREW AND JOINT HOOK MAY BE LIFTED FROM ACTUATING DETENT LEVER.

(THE SHAPE OF SCREW FOR THIS PART IS SHOWN AT BOTTOM OF PAGE)

B. ASSEMBLY PROCEDURE OF JOINT HOOK:

THE JOINT HOOK IS PLACED IN POSITION ON END "A" OF ACTUATING DETENT LEVER AND SHOULDERED SCREW SS-3 REPLACED. JOINT HOOK MUST PIVOT FREELY UNDER THE HEAD OF THIS SCREW.

C. FUNCTION OF JOINT HOOK:

THE FUNCTION OF THE JOINT HOOK IS TO TURN THE CASTLE WHEEL ONE TOOTH EACH TIME THE ACTUATING DETENT LEVER IS MOVED MANUALLY.

REFERENCE: ACTUATING DETENT LEVER IS ASSEMBLY 19
CASTLE WHEEL IS ASSEMBLY 22

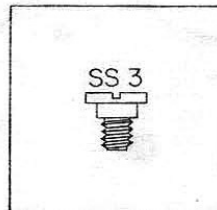

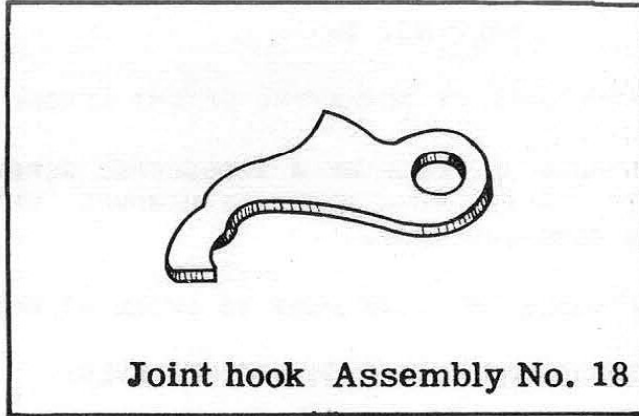

OILING

The shouldered screw SS-3 that joint hook pivots on should be slightly moistened with oil.

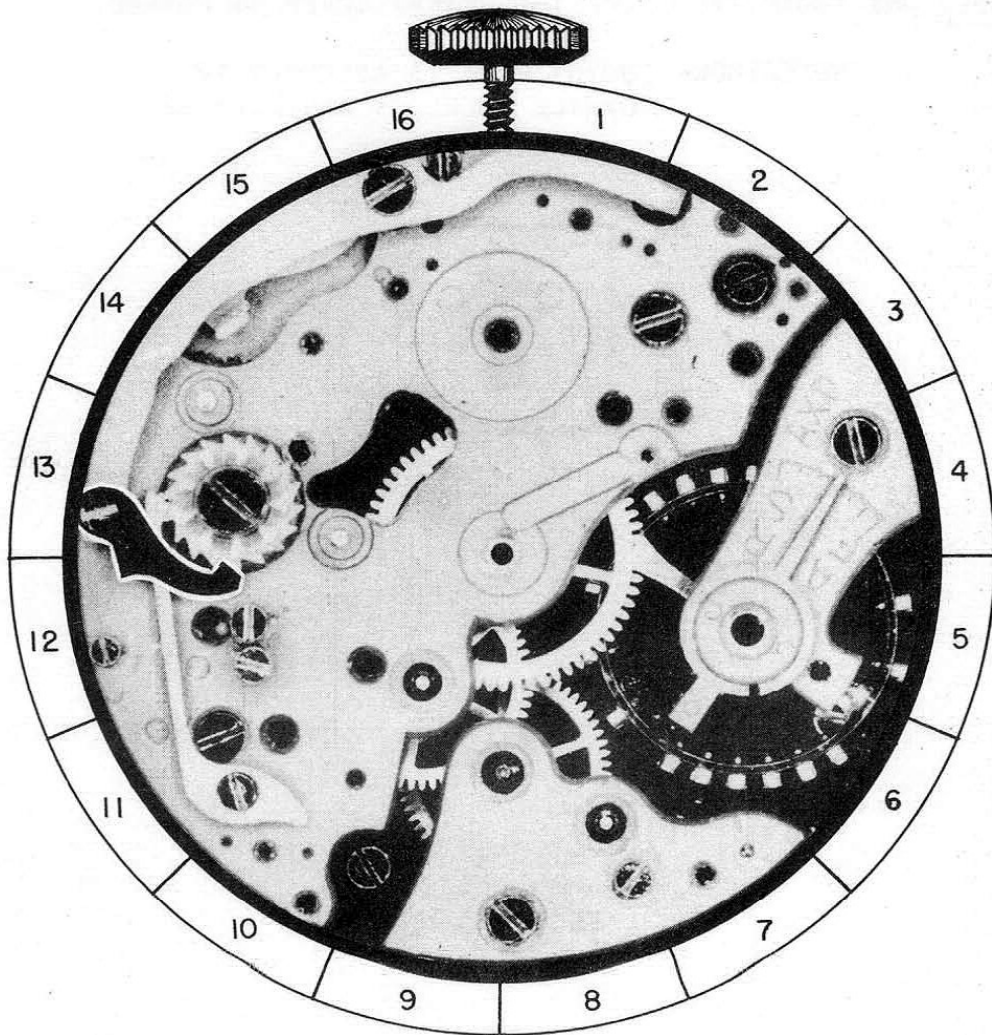

PART NO. 19

A. DISASSEMBLY PROCEDURE OF ACTUATING DETENT LEVER:

THIS LEVER IS HELD IN PLACE BY A SHOULDERED SCREW SS-4 AND PIVOTS ON THIS SCREW. WHEN SCREW IS REMOVED, DETENT LEVER MAY BE LIFTED FROM MOVEMENT.

(THE SHAPE OF SCREW FOR THIS PART IS SHOWN AT BOTTOM OF PAGE)

B. ASSEMBLY PROCEDURE OF ACTUATING DETENT LEVER:

PLACE DETENT LEVER IN PROPER POSITION ON PLATE AS SHOWN IN PICTURE AND REPLACE SHOULDERED SCREW SS-4. DETENT LEVER SHOULD PIVOT FREELY UNDER HEAD OF SCREW.

C. FUNCTION OF ACTUATING DETENT LEVER:

THE FUNCTION OF ACTUATING DETENT LEVER IS TO MOVE THE JOINT HOOK AWAY FROM THE CENTER OF WATCH. THIS TURNS THE CASTLE WHEEL ONE TOOTH EACH TIME THE DETENT LEVER IS PUSHED.

REFERENCE: JOINT HOOK IS ASSEMBLY 18
CASTLE WHEEL IS ASSEMBLY 22

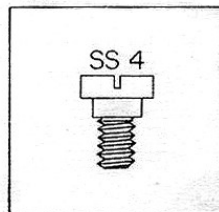

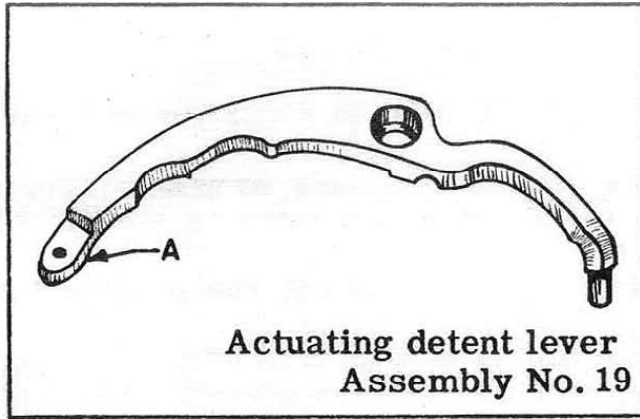

OILING

The shouldered screw SS-4 that actuating detent lever pivot on should be slightly moistened with oil.

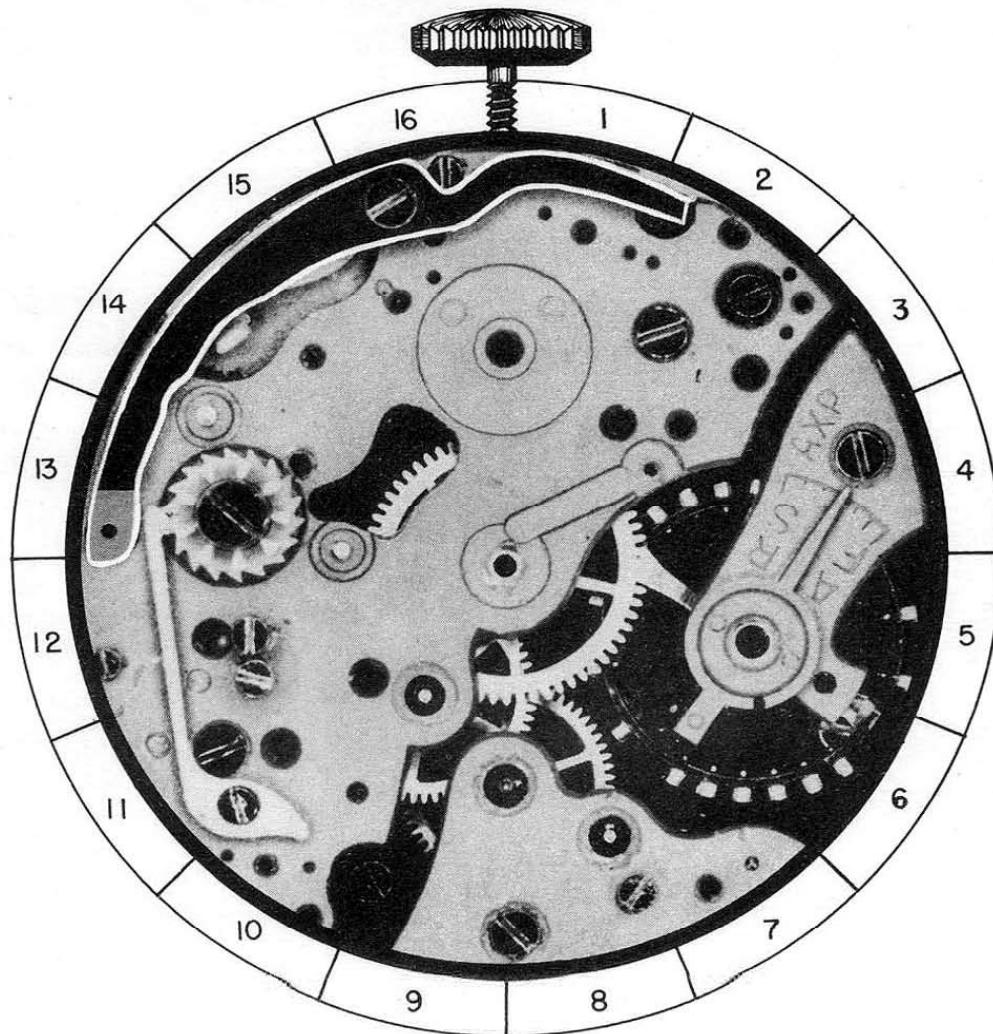

19-A

PART NO. 20

A. DISASSEMBLY PROCEDURE OF PUSH PIECE FOR SETTING BACK TO ZERO:

THE PUSH PIECE FOR SETTING BACK TO ZERO PIVOTS ON POST IN PLATE AND IS LIFTED FROM THIS POST TO REMOVE IT.

B. ASSEMBLY PROCEDURE OF PUSH PIECE FOR SETTING BACK TO ZERO:

HOLE IN PUSH PIECE IS PLACED OVER STUD IN PLATE. THE SCREW TO HOLD PUSH PIECE IN PLACE IS REPLACED AFTER REPLACING ACTUATING DETENT LEVER AS THE SAME SCREW HOLDS BOTH PARTS IN PLACE.

C. FUNCTION OF PUSH PIECE FOR SETTING BACK TO ZERO:

THE FUNCTION OF THIS PUSH PIECE IS, WHEN PUSHED, TO MOVE THE FLY BACK IN TOWARD THE CENTER OF WATCH.

REFERENCE: FLY BACK LEVER IS ASSEMBLY 5

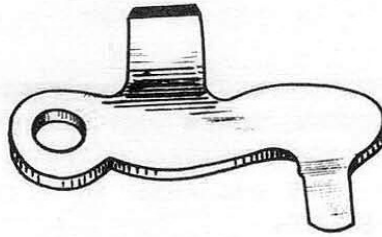

Push piece for setting back
to zero Assembly No. 20

OILING

The post that push piece for setting back to zero pivots
on should be slightly moistened with oil.

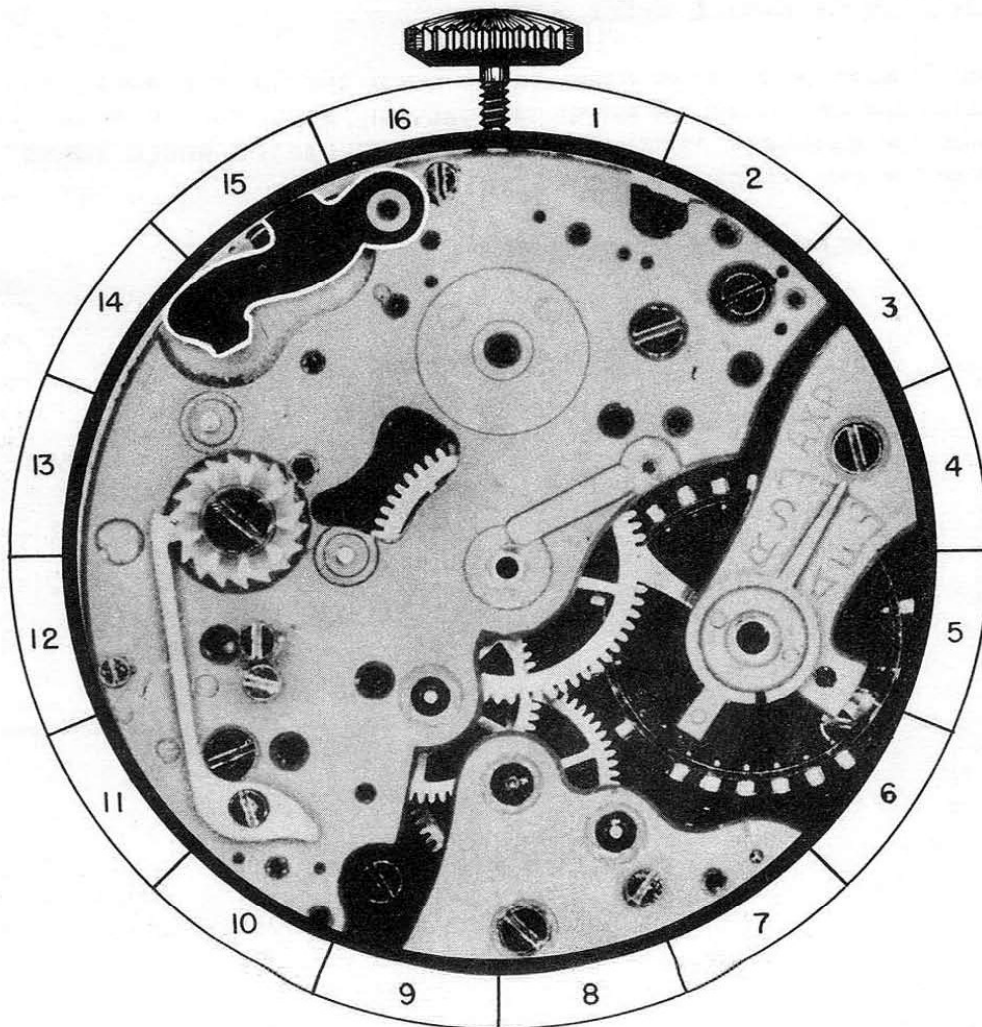

20-A

PART NO. 21

A. DISASSEMBLY PROCEDURE OF CASTLE WHEEL PAWL:

THIS PAWL IS HELD IN PLACE BY BEVELED COUNTERSINK SCREW BS-7 AND STEADY PINS. REMOVE SCREW AND LOOSEN PAWL FROM PLATE BY SLIDING A THIN BLADE SCREWDRIVER BETWEEN THE PLATE AND THE PAWL. AFTER STEADY PINS ARE FREE IN PLATE, THE PAWL MAY BE LIFTED FROM THE MOVEMENT.

(THE SHAPE OF SCREW FOR THIS PART IS SHOWN AT BOTTOM OF PAGE)

B. ASSEMBLY PROCEDURE OF CASTLE WHEEL PAWL:

PLACE PAWL ON PLATE WITH STEADY PINS IN PROPER HOLES. BEFORE PRESSING DOWN IN PLACE, CHECK TO SEE THAT END "A" OF PAWL IS BETWEEN TWO RATCHET TEETH ON THE CASTLE WHEEL. PRESS DOWN TO PLACE AND REPLACE BEVELED COUNTERSINK SCREW BS-7 TO HOLD THIS PART IN POSITION.

C. FUNCTION OF CASTLE WHEEL PAWL:

THE FUNCTION OF THIS PAWL IS TO HOLD THE CASTLE WHEEL IN POSITION UNTIL IT IS MOVED MANUALLY. ALSO THE TENSION OF PAWL ON RATCHETT TEETH MAKES SURE THE CASTLE WHEEL TURNS EXACTLY ONE TOOTH EACH TIME IT IS TURNED.

REFERENCE: CASTLE WHEEL IS ASSEMBLY 22

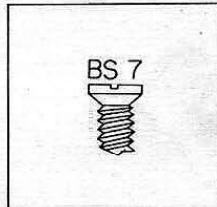

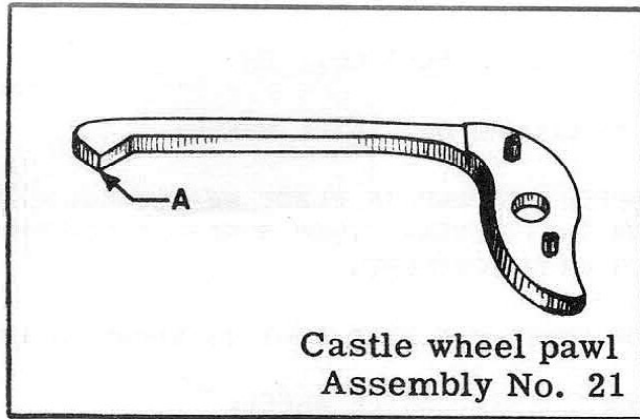

OILING

The castle wheel pawl should not be oiled.

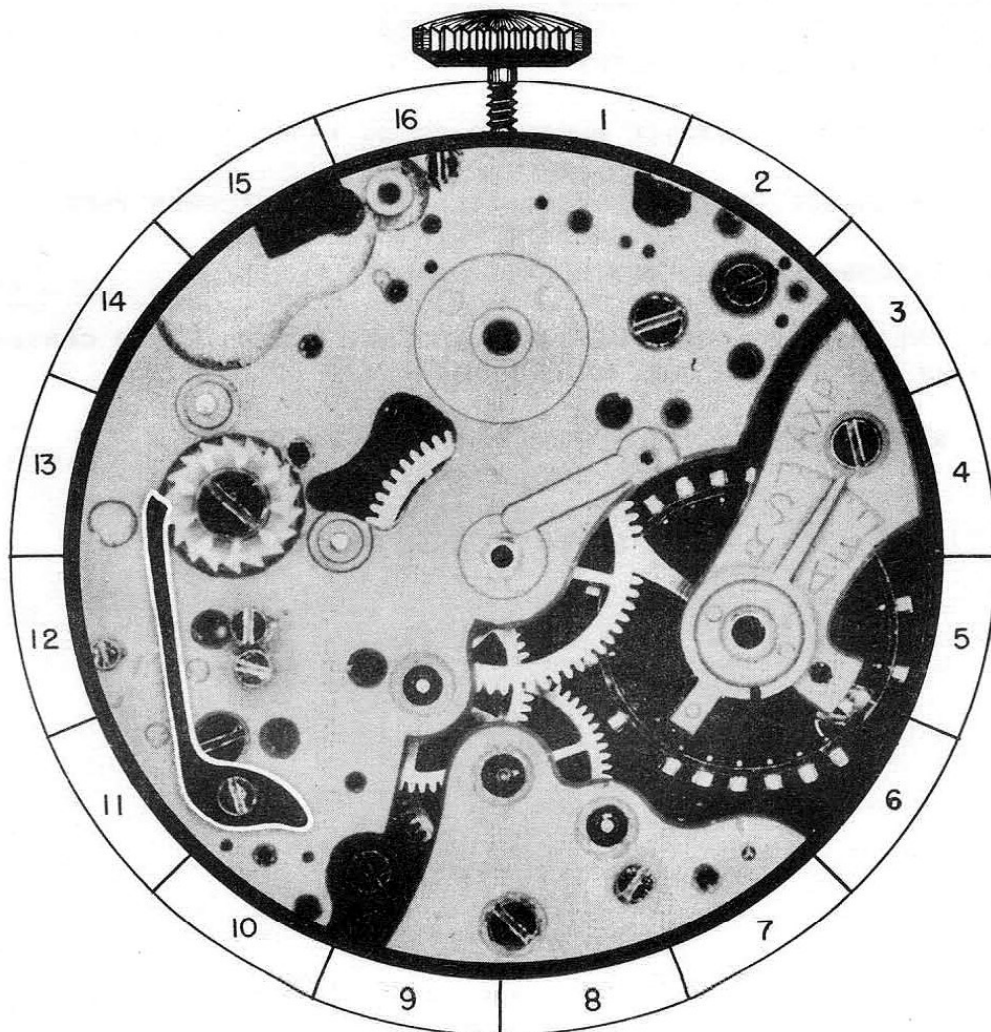

PART NO. 22

A. DISASSEMBLY PROCEDURE OF CASTLE WHEEL:

THE CASTLE WHEEL IS HELD IN PLACE BY A SHOULDERED SCREW SS-5 AND PIVOTS ON THIS SCREW. WHEN SCREW IS REMOVED, CASTLE WHEEL MAY BE LIFTED FROM MOVEMENT.

(THE SHAPE OF SCREW FOR THIS PART IS SHOWN AT BOTTOM OF PAGE)

B. ASSEMBLY PROCEDURE OF CASTLE WHEEL:

PLACE CASTLE WHEEL IN PROPER POSITION ON PLATE AND REPLACE SHOULDERED SCREW SS-5. THE CASTLE WHEEL SHOULD TURN FREELY UNDER HEAD OF SCREW, BUT SHOULD NOT HAVE EXCESS FREEDOM.

C. HAZARDS IN ASSEMBLY OF CASTLE WHEEL:

EXAMINE PLATE AND CASTLE WHEEL FOR BURRS THAT COULD PREVENT WHEEL FROM TURNING FREELY.

D. FUNCTION OF CASTLE WHEEL:

THE FUNCTION OF CASTLE WHEEL IS TO DO THREE THINGS:

1. DISENGAGE INTERMEDIARY WHEEL FROM THE SECONDS WHEEL.
2. DISENGAGE BRAKE LEVER FROM SECONDS WHEEL.
3. PREVENTS FLY BACK LEVER FROM BEING MOVED TOWARD CENTER OF WATCH WHEN CHRONOGRAPH MECHANISM IS ENGAGED.

REFERENCE: INTERMEDIARY WHEEL IS ASSEMBLY 14
SECONDS WHEEL IS ASSEMBLY 7
FLY BACK LEVER IS ASSEMBLY 5
BRAKE LEVER IS ASSEMBLY 9

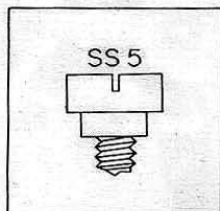

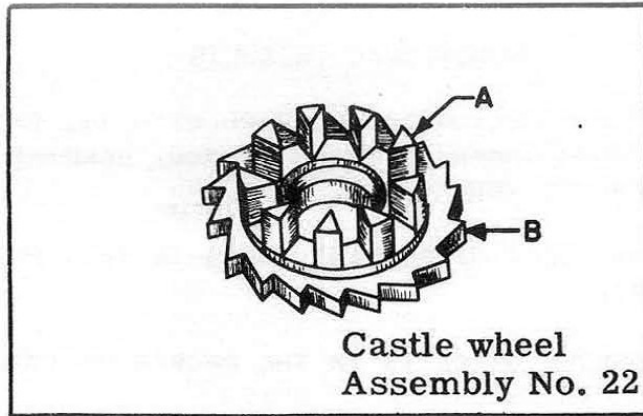

Castle wheel
Assembly No. 22

OILING

- These parts of castle wheel should be slightly moistened with oil.
1. The shouldered screw that castle wheel pivots on.
 2. The columns 'A' on castle wheel at the points they contact the parts of this mechanism.
 3. The ratchet teeth 'B' on castle wheel should be slightly moistened with oil.

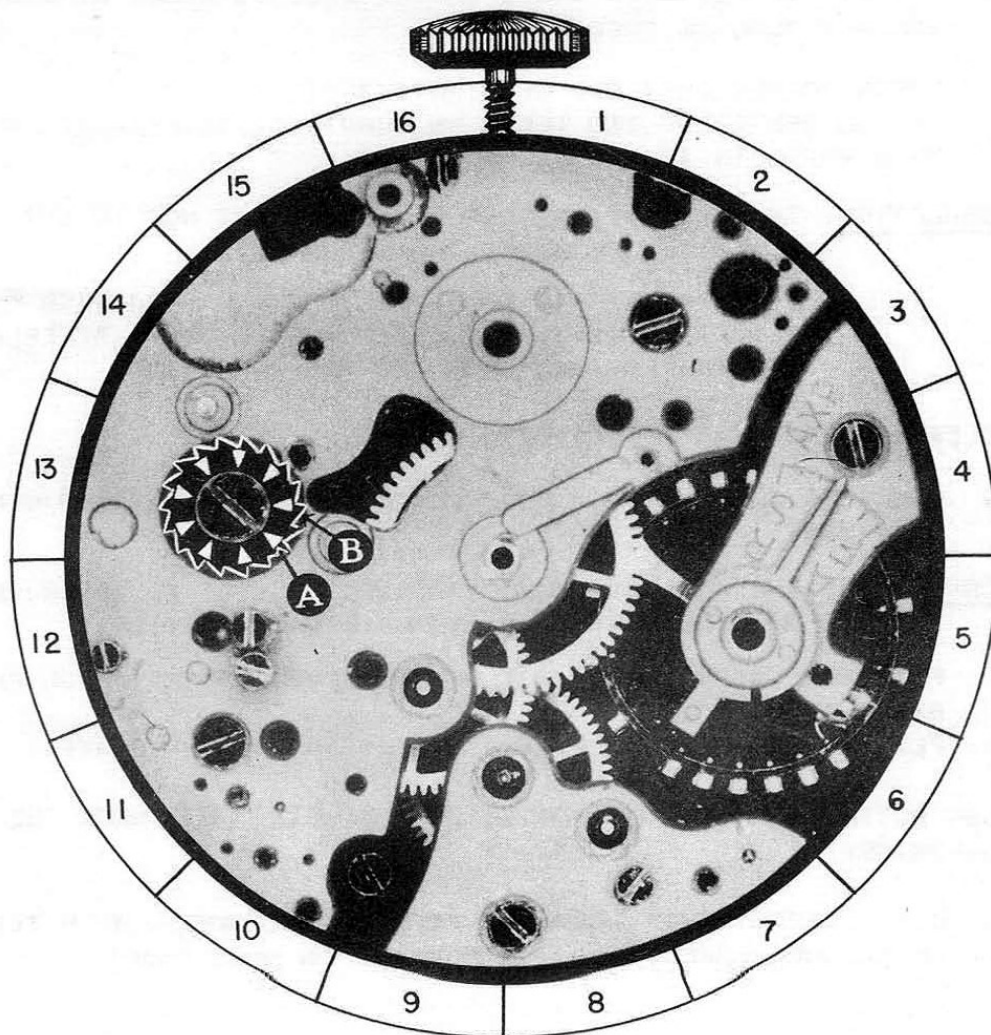

22-A

FUNCTIONAL RESULTS

AFTER COMPLETELY ASSEMBLING CHRONOGRAPH WITH THE EXCEPTION OF BACK OF CASE, PLACE CHRONOGRAPH IN FRONT OF YOU, PENDANT UP WITH BACK OF CHRONOGRAPH FACING YOU.

1. PUSH BUTTON AT LEFT OF PENDANT, HOLD IN THIS POSITION AND CHECK THE FOLLOWING:

(MAKE SURE CASTLE WHEEL IS IN THE PROPER POSITION SO BUTTON CAN BE PUSHED)

- A. CHECK TO SEE THAT SECONDS WHEEL AND MINUTE REGISTER WHEEL RETURN THE HANDS CONNECTED TO THESE WHEELS TO A ZERO POSITION.

CORRECTION: THE FOLLOWING ERRORS COULD PREVENT THESE HANDS FROM RETURNING TO ZERO POSITION.

1. LOOSE HANDS OR HANDS NOT BEING SET CORRECTLY.
2. THE MINUTE REGISTER WHEEL OR THE SECONDS WHEEL BINDING AND NOT TURNING FREELY.
- B. CHECK TO SEE THAT END OF MINUTE REGISTER PAWL LIES DIRECTLY IN THE CENTER OF TWO TEETH ON MINUTE REGISTER WHEEL WHEN THIS WHEEL IS AT A ZERO POSITION.

CORRECTION: THE PAWL BEING BENT WILL CAUSE IT NOT TO SET CORRECTLY ON MINUTE REGISTER WHEEL.

FAILURE TO HAVE THIS PAWL PROPERLY ADJUSTED WILL RESULT IN MINUTE REGISTER WHEEL MOVING AFTER FLY BACK MOVES AWAY FROM HEART.

2. RELEASE BUTTON AND CHECK THE FOLLOWING:

- A. CHECK TO SEE THAT FLY BACK LEVER RETURNS TO ITS ORIGINAL POSITION.

CORRECTION: THE FOLLOWING ERRORS COULD PREVENT FLY BACK LEVER FROM RETURNING TO ITS ORIGINAL POSITION.

1. FLY BACK LEVER SPRING NOT HOLDING ENOUGH TENSION ON FLY BACK LEVER.
2. FLY BACK LEVER NOT TURNING FREELY ON POST IN PLATE.

3. PUSH BUTTON AT RIGHT OF PENDANT, RELEASE IT AND CHECK THE FOLLOWING:

- A. CHECK DEPTHING OF TEETH ON INTERMEDIARY WHEEL WITH TEETH ON SECONDS WHEEL. (CONTINUED ON NEXT PAGE)

FUNCTIONAL RESULTS
(CONTINUED)

CORRECTION: THE FOLLOWING ERRORS COULD PREVENT CORRECT DEPTHING OF THESE TEETH.

1. CHRONOGRAPH PIVOTED DETENT SPRING NOT HOLDING ENOUGH TENSION ON CHRONOGRAPH PIVOTED DETENT.
2. CHRONOGRAPH PIVOTED DETENT NOT TURNING FREELY.
3. IMPROPERLY ADJUSTED ECCENTRIC STUDS COULD PREVENT THE PROPER DEPTHING OF THESE WHEELS.
(SEE ADJUSTMENT OF ECCENTRIC STUDS IN FRONT OF BOOK)

- B. CHECK DEPTHING OF SECONDS WHEEL DART TOOTH WITH INTERMITTENT WHEEL TEETH.

CORRECTION: THE FOLLOWING ERRORS COULD PREVENT PROPER DEPTHING OF DART TOOTH WITH INTERMITTENT WHEEL TEETH.

1. INTERMITTENT LEVER NOT TURNING FREELY ON POST IN PLATE.
2. IMPROPERLY ADJUSTED ECCENTRIC STUD COULD PREVENT PROPER DEPTHING OF THESE PARTS.
(SEE ADJUSTMENT OF ECCENTRIC STUDS IN FRONT OF BOOK)

REMARKS: IF THE DEPTHING OF THE INTERMITTENT WHEEL TEETH WITH THE SECONDS WHEEL DART TOOTH IS DEEP, THE MINUTE REGISTER WHEEL MAY MOVE TWO TEETH EACH TIME THE SECONDS WHEEL MAKES ONE REVOLUTION.

IF THE DEPTHING IS SHALLOW IT MAY CAUSE THE MINUTE REGISTER WHEEL NOT TO MOVE A FULL TOOTH AND THUS WILL NOT REGISTER THE MINUTES ON DIAL.

- C. CHECK TO SEE THAT SECONDS HAND MOVES FORWARD IN A STEADY MANNER WITH NO JUMPING OR JERKING.

CORRECTION: THIS IRREGULAR MOVEMENT OF THE SECONDS HAND IS USUALLY CAUSED BY THE SECONDS WHEEL TENSION SPRING NOT HOLDING ENOUGH TENSION ON SECONDS WHEEL

4. PUSH BUTTON AT RIGHT OF PENDANT A SECOND TIME, RELEASE IT AND CHECK THE FOLLOWING:
 - A. CHECK TO SEE THAT BRAKE LEVER IS IN CONTACT WITH SECONDS WHEEL.

CORRECTION: THE FOLLOWING ERRORS COULD PREVENT BRAKE LEVER CONTACTING SECONDS WHEEL.

1. BRAKE LEVER NOT TURNING FREELY UNDER HEAD OF SCREW.
2. BRAKE LEVER SPRING NOT HOLDING ENOUGH TENSION ON BRAKE LEVER.

DIRECTIONS FOR READING CHRONOGRAPH DIAL

THE TACHOMETER

- A. The tachometer is used to indicate the speed of an object in miles per hour. A tachometer can only indicate the average speed of an object traveling over a course of a measured mile.

METHOD OF USING TACHOMETER

1. Start chronograph sweep second hand at the exact moment the object starts to travel the measured distance of one mile.
2. When the object has traveled the course of one mile, stop the chronograph at the point on the tachometer scale where the sweep second hand stopped. It will indicate the average speed in miles per hour.

SPLIT SECOND SCALE

- B. This scale is divided into 300 divisions. Each indicating $1/5$ of a second every fifth division is marked with extra long lines denoting one second.

The main purpose of this scale is to measure a fraction of a second accurately.

SECOND HAND

- C. The second hand indicates the passing of seconds and should move one space each second. One complete revolution of hand denotes passage of one minute. This hand is independent of chronograph mechanism and continues to register the seconds as long as watch is running.

TELEMETER

- D. The telemeter is used to denote the number of miles between two points. This is done by comparing the speed of light to the speed of sound.

METHOD OF USING TELEMETER

1. Start chronograph sweep second hand when you see lightning.
2. Stop the chronograph sweep second hand when you hear the thunder. The point on the telemeter scale where the sweep second hand stopped will indicate the distance in miles the lightning is away from you.

MINUTE REGISTER

- E. The minute register hand registers the number of minutes the chronograph has been in operation. This hand should move forward one space each minute that the chronograph is in operation.

THE CHRONOGRAPH DIAL

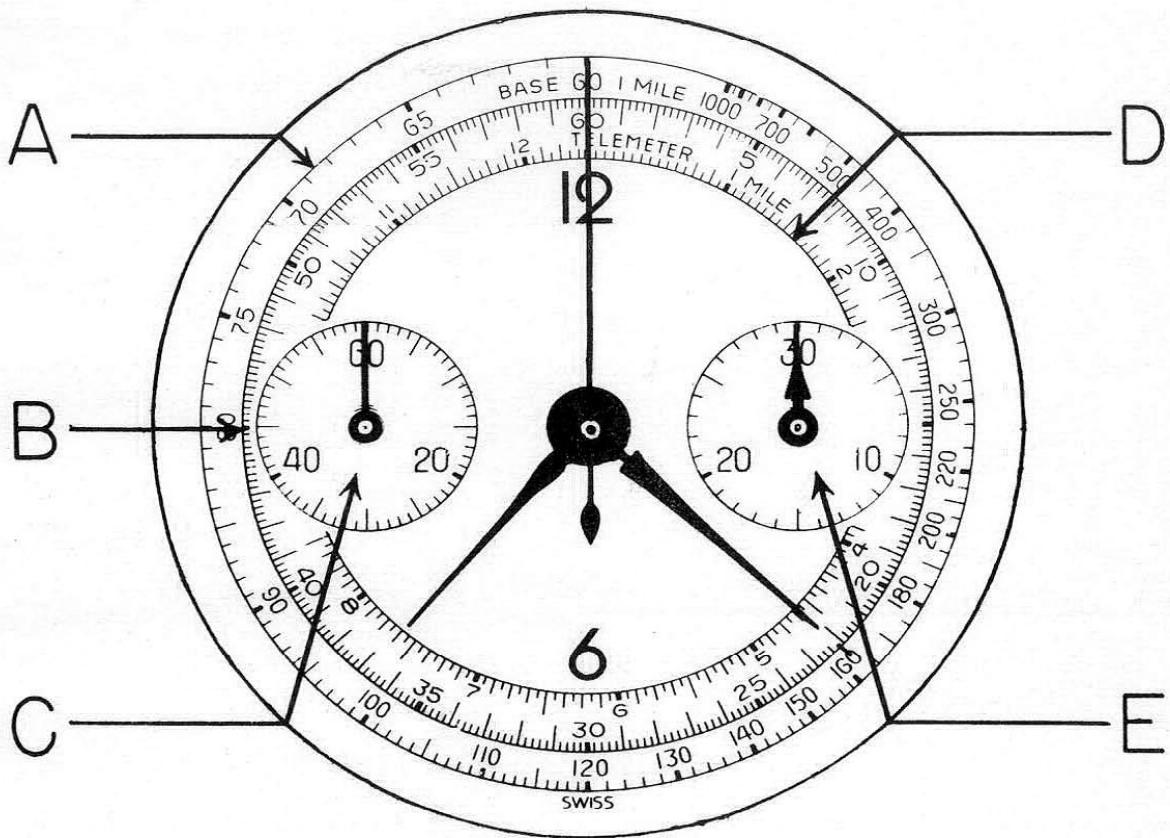

SETTING THE HANDS CORRECTLY ON A CHRONOGRAPH:

After the chronograph is completely assembled and in working condition, place chronograph in its case. Now replace the hands, replace the hour hand, minute hand and second hand as you would on a regular watch. At this point, do not replace the sweep second or the minute register hand. Now push the button and bring the flyback lever in toward the center of the watch. When the flyback lever is held in toward the center of the watch, place the sweep second hand at 60 on split second scale 'B'. Place the minute register hand at 30 on minute register scale 'E'. After these hands are replaced, start chronograph mechanism with sweep second hand turning. Leave chronograph mechanism run for at least one minute, now push the button to bring the flyback lever in toward the center of the watch again, and check to see that the minute register hand and the sweep second hand goes back to their original position.