

WORLD'S ONLY  
FULLY ILLUSTRATED  
**CHRONOGRAPH WATCH COURSE**  
VOLUME 9

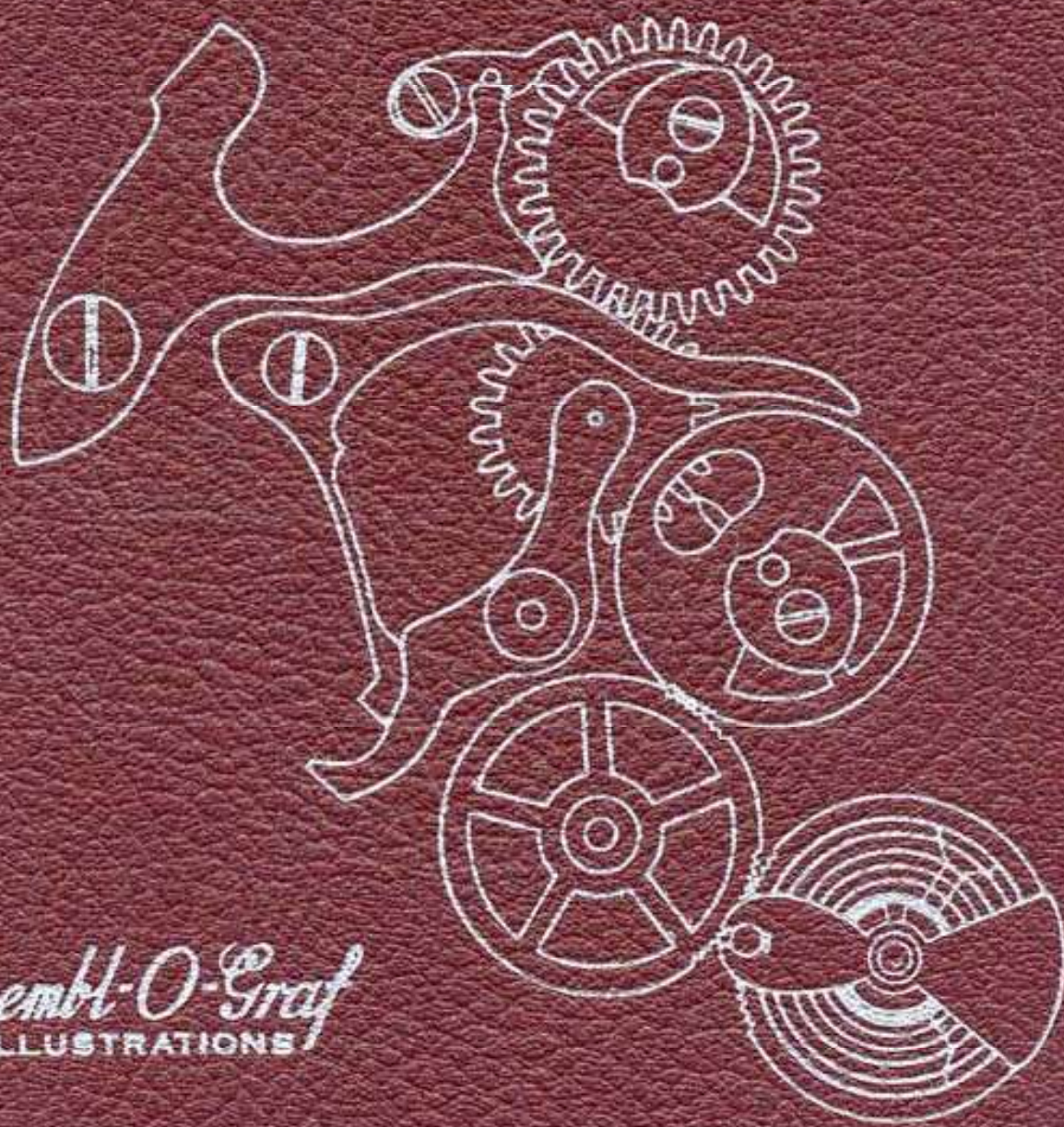

*Essemb-O-Graf*  
ILLUSTRATIONS



# IDENTIFICATION OF CHRONOGRAPH

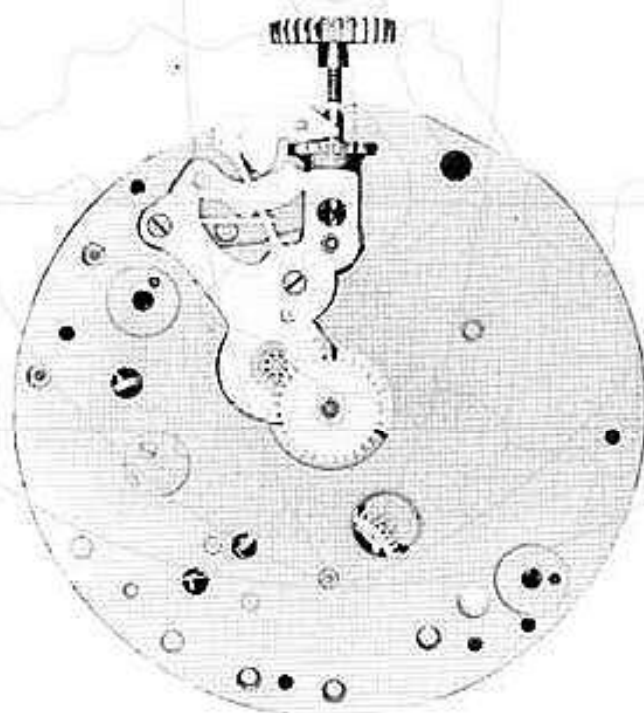

13L



VENUS  
CAL. 150



# ESEMBL-O-GRAF

THE WORLD'S FIRST FULLY  
ILLUSTRATED TEXT BOOK  
ON  
CHRONOGRAPH REPAIRING  
AND ADJUSTING

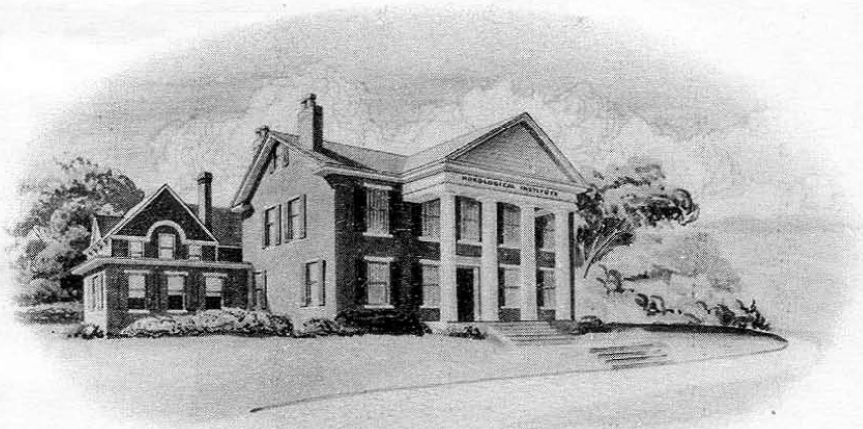

BY  
**William O. Smith, Sr.**  
PRESIDENT AND TECHNICAL DIRECTOR  
AND  
**William O. Smith, Jr.**  
CHIEF ENGINEER, RESEARCH LABORATORIES

WESTERN PENNSYLVANIA HOROLOGICAL INSTITUTE, INC.  
PITTSBURGH, PENNSYLVANIA



This page intentionally left blank

## INSTRUCTIONS

For use of book

### DISASSEMBLY OF THE CHRONOGRAPH MECHANISM:

1. Study the isometric drawing at top of page 1-A. The isometric drawing was made for the following purposes:
  - A. It helps to identify the part to be removed.
  - B. This drawing aids in pointing out certain locations on the part that are mentioned in the oiling procedure.
  - C. The text refers to certain points on the part. These points are shown in the isometric drawing. This should aid you in finding the exact location on the part that is described in the text.
  - D. It helps you to know the shape of the part in case a new part has to be made.
2. At the bottom of the page 1-A is a photograph of a chronograph. In this photograph is the same part painted in black. The part is in its exact location that this part occupies in the watch. Find this location in the watch.
3. Read the disassembly procedure and the hazards in disassembly on page 1 in this book.
4. Remove this part in the same procedure as described in the text.
5. A very important item in disassembling a chronograph is keeping the screws in order, much time will be lost in putting the chronograph together if screws are mixed up. This means you have to hunt for each screw, sometimes trying three or four screws before finding the correct one. It cannot be stressed too strongly that care should be taken so that screws are not mixed up. The system that we advise for beginners, is to replace each individual screw after each part is removed. This naturally eliminates the hazard of mixing up the screws and will save you much time in the end. Do this at least until you become so thoroughly familiar with the chronograph that you no longer feel it is necessary.
6. Continue to follow this procedure throughout the book and disassemble each part until the last part of the chronograph is removed.

### ASSEMBLY OF THE CHRONOGRAPH MECHANISM:

7. When you are ready to assemble the chronograph mechanism, study the isometric drawing on the last part in this book. This drawing should aid you in identifying the part to be assembled.
8. At the bottom of this page is a photograph of a chronograph. In this photograph is the same part painted in black. The part is in its exact location that this part occupies in the watch.
9. Read the assembly procedure and the hazards in assembling for the last part in this book. (Continued on next page)



## INSTRUCTIONS (Continued)

10. Replace the part in its exact location as shown in photograph, using the procedure as described in the text.

11. After you find the correct location for this part in the watch, read the oiling procedure for this part. The oiling procedure for this part is located underneath the isometric drawing. It is best to read the oiling procedure before you put each part in place as there are certain parts that must be oiled immediately as it may prove difficult to oil them later.

12. Replace the screw that holds this part in place. Of course, the screws should be kept in order as we advised above, but if the screws are not in order or the watch was received with screws mixed up, you will find a screw drawn for each part that requires a screw at the bottom of the text page.

13. After replacing this part, replace the next part, etc., until the last part is replaced, which will be part No. 1. Each part should be replaced using the same procedure as described in the text.

(Naturally, the assembly of the chronograph is exactly the reverse of the disassembly)

14. After disassembling and assembling the chronograph mechanism, start on page 1 and read the function of this part. After reading the function of this part, continue to read the function of each part throughout the book. Study each part, one at a time. This text should help you to understand more fully the purpose of each part in the chronograph mechanism.

15. Now put movement in its case with dial on, then replace hands.

16. Study the text on functional results in this book, and check the chronograph mechanism as described in this text.

### NOMENCLATURE OF PARTS FOR CHRONOGRAPH MECHANISM

17. After you have become familiar with the chronograph mechanism, you can disassemble and assemble the chronograph by using the nomenclature of parts as a guide. This makes it possible for you to use a procedure without going through each page in the book.

#### 18. ADJUSTMENT OF ECCENTRIC STUDS:

Read the text on adjustment of eccentric studs, this text should be read in reference to the eccentric stud picture. Now adjust each eccentric stud one at a time in the watch, as described in the text. Use the picture to show you the position of these studs.

19. On each page in this book the part number and the page number are the same. This makes it convenient for the reader and eliminates any confusion.

# NOMENCLATURE OF PARTS FOR CHRONOGRAPH MECHANISM

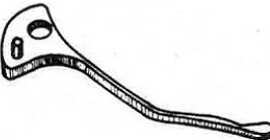
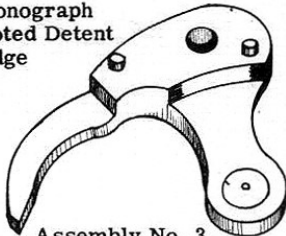
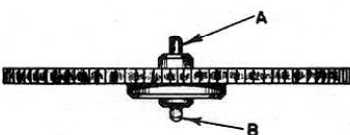
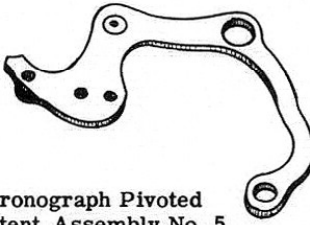
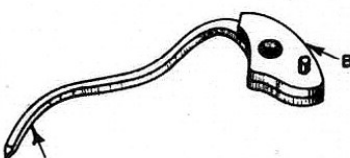
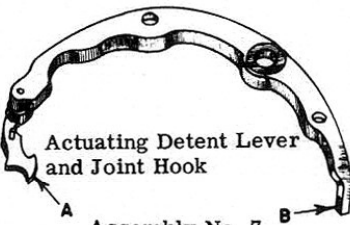
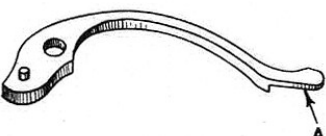
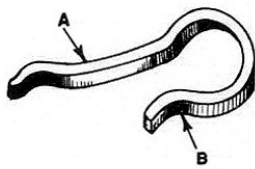
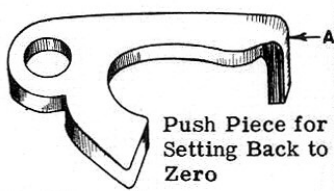
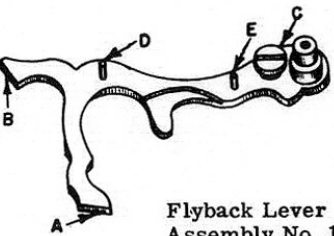
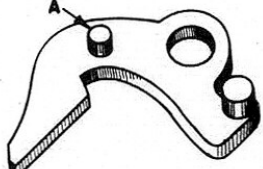
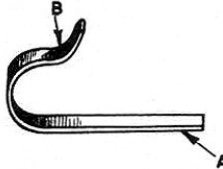
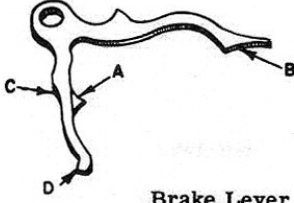
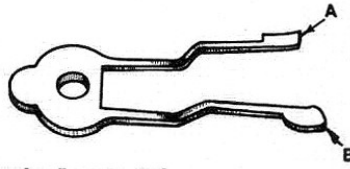
 <p style="text-align: center;">Wheel Over Fourth Wheel Assembly No. 1</p>	 <p style="text-align: center;">Chronograph Pivoted Detent Spring Assembly No. 2</p>	 <p style="text-align: center;">Chronograph Pivoted Detent Bridge Assembly No. 3</p>
 <p style="text-align: center;">Intermediary Wheel Assembly No. 4</p>	 <p style="text-align: center;">Chronograph Pivoted Detent Assembly No. 5</p>	 <p style="text-align: center;">Actuating Detent Lever Spring Assembly No. 6</p>
 <p style="text-align: center;">Actuating Detent Lever and Joint Hook Assembly No. 7</p>	 <p style="text-align: center;">Flyback Lever Spring Assembly No. 8</p>	 <p style="text-align: center;">Push Piece for Setting Back to Zero Spring Assembly No. 9</p>
 <p style="text-align: center;">Push Piece for Setting Back to Zero Assembly No. 10</p>	 <p style="text-align: center;">Flyback Lever Assembly No. 11</p>	 <p style="text-align: center;">Flyback Trip Lever Assembly No. 12</p>
 <p style="text-align: center;">Flyback Trip Lever Spring Assembly No. 13</p>	 <p style="text-align: center;">Brake Lever Assembly No. 14</p>	 <p style="text-align: center;">Brake Lever and Intermittent Lever Spring Assembly No. 15</p>

Continued on next page



# NOMENCLATURE OF PARTS FOR CHRONOGRAPH MECHANISM

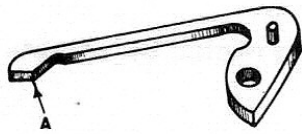

Castle Wheel Pawl  
Assembly No. 16

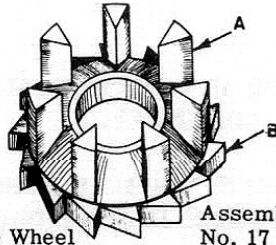

Castle Wheel  
Assembly No. 17

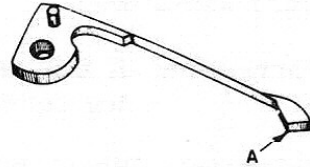

Minute Register Pawl  
Assembly No. 18

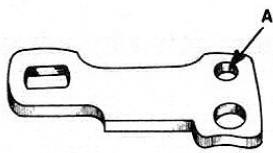

Minute Register Pawl  
Adjusting Plate Assembly No. 19

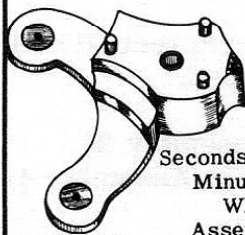

Seconds Wheel and  
Minute Register  
Wheel Bridge  
Assembly No. 20

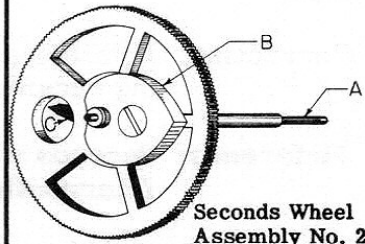

Seconds Wheel  
Assembly No. 21

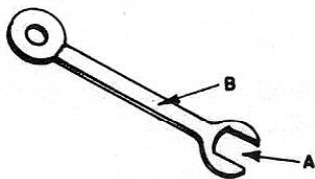

Seconds Wheel Tension Spring  
Assembly No. 22

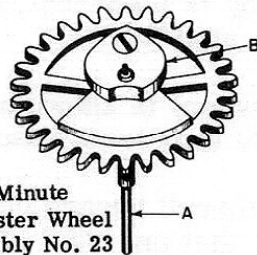

Minute  
Register Wheel  
Assembly No. 23

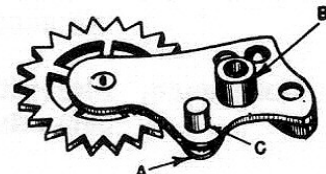

Intermittent Lever and Wheel  
Assembly Assembly No. 24

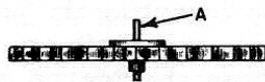

Intermittent Wheel  
Assembly No. 24-B

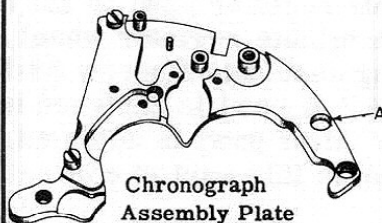

Chronograph  
Assembly Plate  
Assembly No. 25



Sweep Second Hand.



Minute Register Hand.

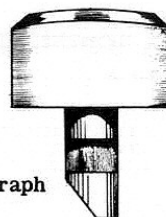

Chronograph  
Button.

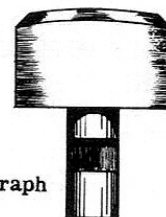

Chronograph  
Button.

## ADJUSTING ECCENTRIC STUDS - THINGS TO CHECK

Listed below are a number of depthings and adjustments controlled by the eccentric studs:

1. Check the depthing of the wheel over fourth wheel teeth with the intermediary wheel teeth.

**Correction:** If this depthing is incorrect, it can be corrected by adjusting eccentric stud ES-1.

**Reference:** Wheel over fourth wheel is Assembly 1.  
Intermediary wheel is Assembly 4.

2. Check depthing of the seconds wheel teeth with the intermediary wheel teeth.

**Correction:** If this depthing is incorrect, it can be corrected by adjusting eccentric stud ES-2.

**Reference:** Seconds wheel is Assembly 21.  
Intermediary wheel is Assembly 4.

3. Check depthing of intermittent wheel teeth with seconds wheel dart tooth.

**Correction:** If this depthing is incorrect, it can be corrected by adjusting eccentric stud ES-3.

**Reference:** Intermittent wheel is shown on Page 24-C.  
Seconds wheel dart tooth Assembly 21-C.

4. When the flyback lever is forced toward center of watch and held in this position, check to see that end "A" of minute register pawl is centered between two teeth on the minute register wheel.

**Correction:** If the minute register pawl is not centered between two teeth on the minute register wheel, this can be corrected by loosening shouldered screw SS-8 and adjusting the pawl until end "A" of pawl is centered between two teeth on this wheel. After pawl is adjusted, tighten shouldered screw SS-8 that holds this part in correct position.

**Reference:** Flyback lever is Assembly 11.  
Minute register pawl is Assembly 18.  
Minute register wheel is Assembly 23.

For more detailed information on adjusting the minute register pawl, see Page 28.



# ADJUSTING ECCENTRIC STUDS

DO NOT REMOVE THESE STUDS

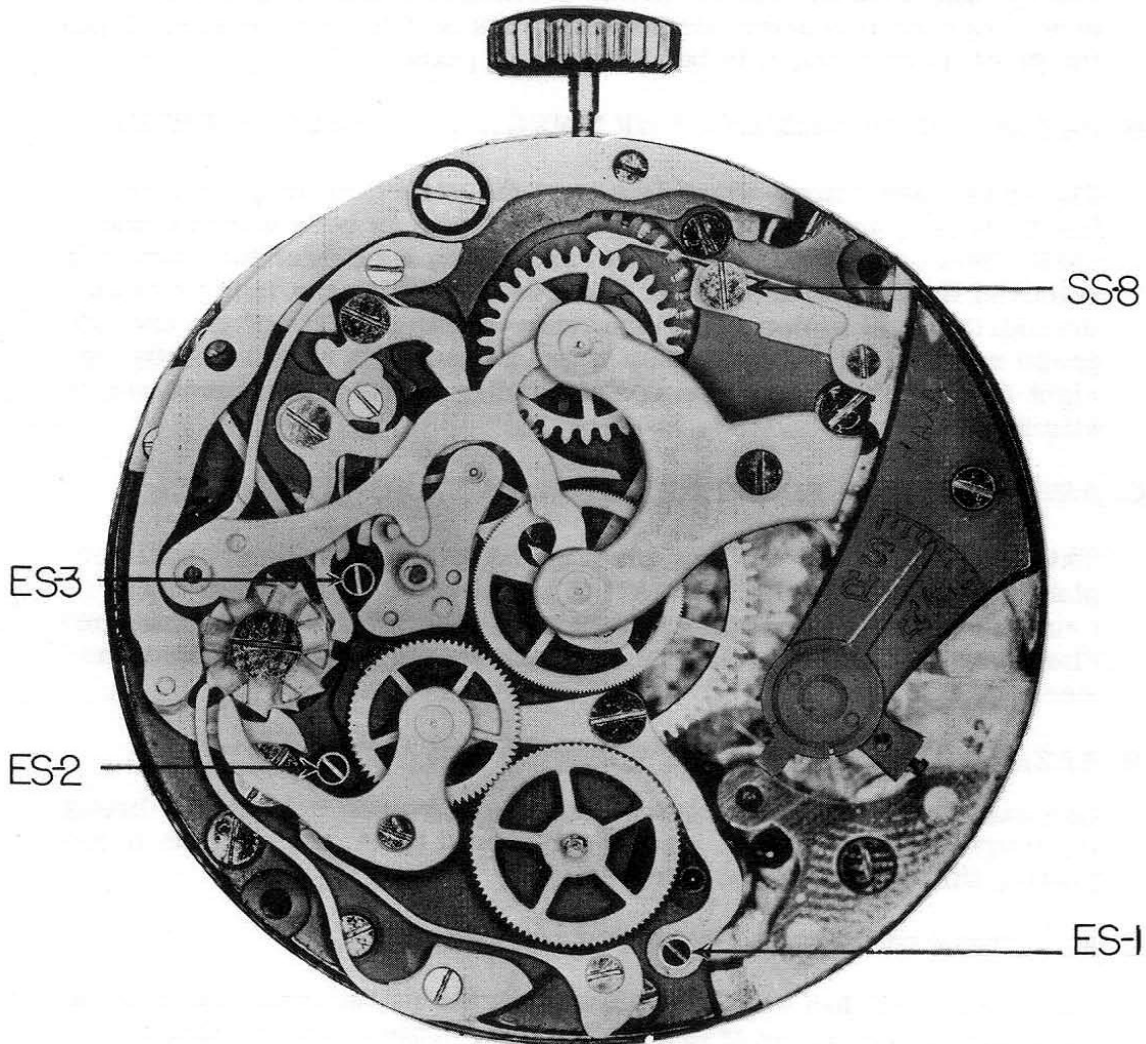

## CAUTION

In disassembling or assembling the chronograph, it is a good policy not to turn the eccentric studs. These eccentric studs are used to adjust one part to another. Naturally, in turning these studs, you will lose the desired adjustment of the chronograph mechanism. This will cause the chronograph to function incorrectly. Another reason for not turning these studs unless it is necessary is, that they soon become loose and will not hold the desired adjustment.

## PART NO. 1

### A. DISASSEMBLY PROCEDURE OF WHEEL OVER FOURTH WHEEL:

The wheel over fourth wheel fits friction tight on long pivot of the fourth wheel pinion. This wheel should be removed with a sweep wheel remover, but can be removed with two small, thin edge, screwdrivers. The screwdrivers are placed opposite each other under hub "A" of wheel. One screwdriver is turned clockwise while the other screwdriver is turned counter-clockwise. This will loosen the wheel from the pivot, permitting it to be lifted out of place.

### B. HAZARDS IN DISASSEMBLY OF WHEEL OVER FOURTH WHEEL:

The wheel over fourth wheel fits over the very thin, long pivot of fourth wheel pinion. This pivot, as you know, is very delicate and easily bent or broken. The main reason why we select this part to be removed first is, to lessen the hazards of bending the long pivot on the fourth wheel pinion when removing the other parts of the chronograph mechanism. If the sweep wheel remover is held perfectly upright in removing wheel, hazard of bending fourth wheel pivot will be eliminated.

### C. ASSEMBLY PROCEDURE OF WHEEL OVER FOURTH WHEEL:

This wheel fits over the long pivot of the fourth wheel and should be placed on the pivot with hub "A" of wheel down. The wheel over fourth wheel should be staked down until it is level with the intermediary wheel. A hollow, flat-faced punch should be used to stake the wheel down.

### D. HAZARDS IN ASSEMBLY OF WHEEL OVER FOURTH WHEEL:

Use care in staking down this wheel so that you do not bend or break the fourth wheel pivot. If movement is held level, the hazards in replacing this wheel will be eliminated.

### E. FUNCTION OF WHEEL OVER FOURTH WHEEL:

The function of this wheel is to transmit the power from the train of the watch to the chronograph mechanism. This wheel continues to turn, as long as the watch is running.

### REMARKS:

Mechanically, we should regard this wheel as an intermediate chronograph wheel, as it is the main wheel which transfers the power from the movement train to the chronograph mechanism. The Swiss term for this part is "wheel over fourth wheel", and we will use this term to describe this wheel.

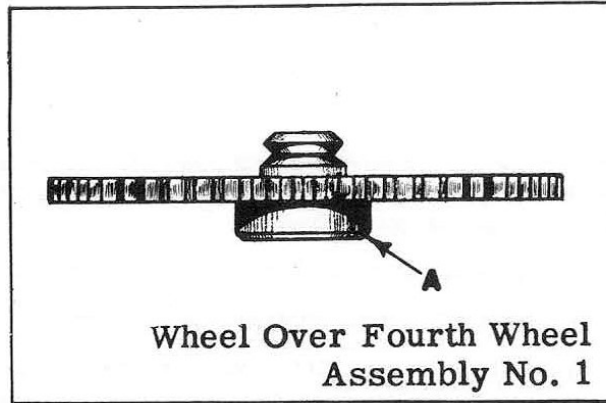

### OILING

The wheel over fourth wheel should not be oiled.



1A



## PART NO. 2

### A. DISASSEMBLY PROCEDURE OF CHRONOGRAPH PIVOTED DETENT SPRING:

This spring is held in place by beveled countersink screw BS-1 and a steady pin. Remove screw, and steady pin will be free in plate, and the detent spring may be lifted from the movement.

(The shape of screw for this part is shown at the bottom of the page.)

### B. ASSEMBLY PROCEDURE OF CHRONOGRAPH PIVOTED DETENT SPRING:

Place the spring in position on the plate, with steady pin in proper hole. End "A" of spring should be on lip "A" of the chronograph pivoted detent. Replace beveled countersink screw BS-1 that holds this spring in place.

### C. FUNCTION OF CHRONOGRAPH PIVOTED DETENT SPRING:

The functions of this spring are:

1. It holds a tension on the chronograph pivoted detent forcing it toward the center of the watch.
2. It helps to hold the chronograph pivoted detent down in position on the plate.

REFERENCE: Chronograph pivoted detent is Assembly 5.

#### REMARKS:

The tension of the chronograph pivoted detent spring on the chronograph pivoted detent must be strong enough to engage the intermediary wheel with the seconds wheel. Any excess tension tends to make the chronograph mechanism harder to work manually.

At this point, the intermediary wheel should be checked to see that it will not rise enough to be out of mesh with seconds wheel.

The endshake of the intermediary wheel, plus the vertical movement or endshake of chronograph pivoted detent under the screw-head that holds it in place, should not be enough to permit the intermediary wheel to rise enough to be out of mesh with the seconds wheel.

Any excess freedom of chronograph pivoted detent under the screwhead, plus the endshake of intermediary wheel, may permit the intermediary wheel to drop below the seconds wheel, when the chronograph is placed in dial up position.

REFERENCE: Seconds wheel is Assembly 21.  
Intermediary wheel is Assembly 4.

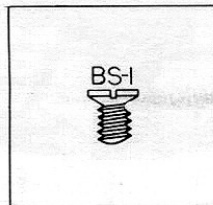

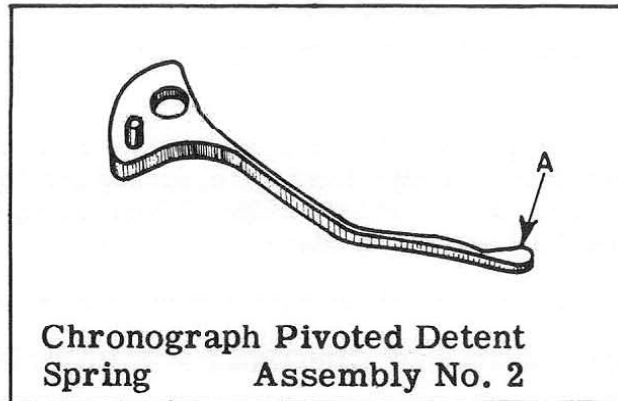

### OILING

End "A" on chronograph pivoted detent spring should be slightly moistened with oil at point of contact with chronograph pivoted detent.



2A

### PART NO. 3

#### A. DISASSEMBLY PROCEDURE OF CHRONOGRAPH PIVOTED DETENT BRIDGE:

This bridge is held in place by fillister head screw FS-1 and steady pins. Remove screw and loosen bridge from chronograph pivoted detent, by sliding a thin blade screw-driver under bridge. When steady pins are free in detent, bridge may be lifted out of place.

(The shape of screw for this part is shown at the bottom of page.)

#### B. HAZARDS IN DISASSEMBLY OF CHRONOGRAPH PIVOTED DETENT BRIDGE:

When using a screw-driver to loosen bridge from detent, care should be taken to keep bridge level, as any twisting may damage pivot on intermediary wheel or burr the bushing in bridge or pivoted detent. The screw-driver should be carefully used to prevent marring of bridge or detent.

#### C. ASSEMBLY PROCEDURE OF CHRONOGRAPH PIVOTED DETENT BRIDGE:

Place bridge on chronograph pivoted detent with steady pins over proper holes in detent. Place intermediary wheel so that pivot on this wheel will enter bushing in bridge. Bridge may now be pressed down to proper place with back of tweezers and fillister head screw FS-1 replaced in bridge.

REFERENCE: Chronograph pivoted detent is Assembly 5.  
Intermediary wheel is Assembly 4.

#### D. HAZARDS IN ASSEMBLY OF CHRONOGRAPH PIVOTED DETENT BRIDGE:

Keep bridge level when pressing down to proper place, as any twisting may burr the bushing in the bridge or damage the pivot on intermediary wheel. The bridge and detent, where these two parts come together, should be checked to see that there are no burrs which would prevent bridge from setting properly on chronograph pivoted detent. At this point it is advisable to check the intermediary wheel to see that it has proper endshake. Also check to see that it spins freely.

#### E. FUNCTION OF CHRONOGRAPH PIVOTED DETENT BRIDGE:

The function of this bridge is to hold the intermediary wheel in position, so that it can function properly.

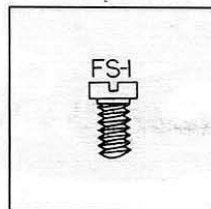



**Chronograph  
Pivoted Detent  
Bridge**

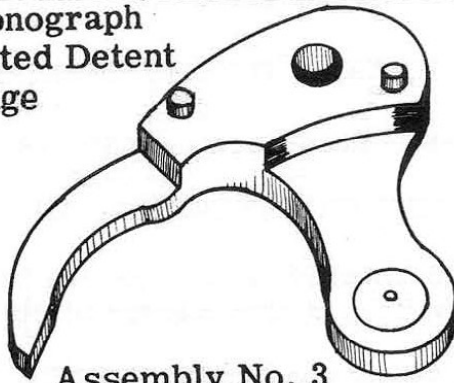

**Assembly No. 3**

**OILING**

The pivot in bushing hole in this bridge should be oiled as you usually oil a train pivot in a watch.



**3A**

## PART NO. 4

### A. DISASSEMBLY PROCEDURE OF INTERMEDIARY WHEEL:

To remove the intermediary wheel, simply lift it out of place.

### B. ASSEMBLY PROCEDURE OF INTERMEDIARY WHEEL:

The end "A" of staff should be up. Place the bottom pivot "B" of staff in hole in bushing in chronograph pivoted detent.

### C. HAZARDS IN ASSEMBLY OF INTERMEDIARY WHEEL:

Pivot hole in bushing in chronograph pivoted detent should be carefully examined before replacing intermediary wheel. Any imperfection here will affect the timekeeping of the watch and hinder the proper operation of the chronograph.

REFERENCE: Chronograph pivoted detent is Assembly 5.

### D. FUNCTION OF INTERMEDIARY WHEEL:

The function of the intermediary wheel is to transfer the power from the wheel over fourth wheel to the seconds wheel, when these wheels are engaged. The intermediary wheel continues to turn as long as the watch is running.

REFERENCE: Chronograph pivoted detent is Assembly 5.  
Seconds wheel is Assembly 21.  
Wheel over fourth wheel is Assembly 1.

### REMARKS:

A careful and detailed examination should be made of all wheels before replacing in the chronograph. Each wheel should be examined for burred pivots, bent or burred teeth, dirt or small pieces of grit wedged between the teeth.

When the VEE shaped teeth of one wheel meshes into the VEE shaped teeth of another wheel, there is very little clearance between the teeth. Because of this, even the smallest piece of grit or dirt wedged into one of these teeth may stop the chronograph. The intermediary wheel has VEE shaped teeth.

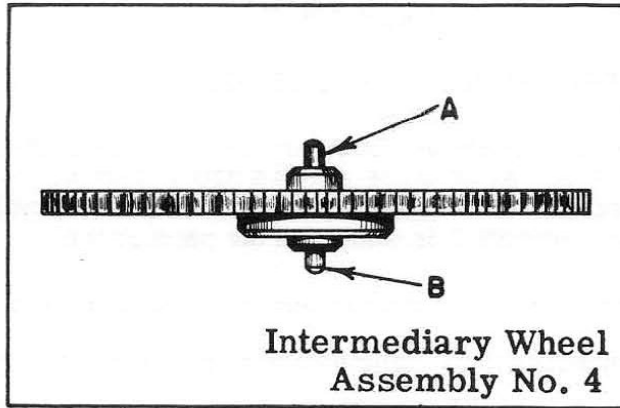

Intermediary Wheel  
Assembly No. 4

### OILING

The bottom pivot on intermediary wheel should be oiled before placing this wheel in chronograph pivoted detent. The top pivot is oiled after bridge for this wheel is replaced.



4A



## PART NO. 5

### A. DISASSEMBLY PROCEDURE OF CHRONOGRAPH PIVOTED DETENT:

This detent is held in place by shouldered screws SS-1 and SS-2, and pivots on an eccentric stud. After these screws are removed, the detent may be lifted from eccentric stud and free of movement. The position of shouldered screws SS-1 and SS-2 is shown in the photograph.

(The shape of screws for this part is shown at the bottom of page.)

### B. ASSEMBLY PROCEDURE OF CHRONOGRAPH PIVOTED DETENT:

Place the detent on the plate, with hole in end of detent over eccentric stud, as detent pivots on this stud. When detent is in place, shouldered screws SS-1 and SS-2 should be replaced. Detent must move freely under the heads of these screws. The positions of these screws are shown in the photograph.

### C. HAZARDS IN ASSEMBLY OF CHRONOGRAPH PIVOTED DETENT:

After replacing detent, check to see that it has enough freedom to move freely under the heads of shouldered screws, and yet does not have excess freedom.

### D. FUNCTION OF CHRONOGRAPH PIVOTED DETENT:

The function of the chronograph pivoted detent is to engage and disengage the intermediary wheel with the seconds wheel.

**REFERENCE:** Intermediary wheel is Assembly 4.  
Seconds wheel is Assembly 21.

#### REMARKS:

When disassembling the chronograph, each part should be carefully examined as it is removed from the movement. Each part should be checked against the isometric drawings to see that the part is the correct shape and is not broken. Each part should also be checked for any pits of rust, roughness, or burrs and for worn parts which may cause the part not to work properly.

The replacement of a defective part in the chronograph may necessitate complete disassembly of the chronograph. Through a close examination of each part, you will soon become familiar with the parts of the chronograph. This will enable you to quickly recognize a defective part and repair it before replacing it in the chronograph.

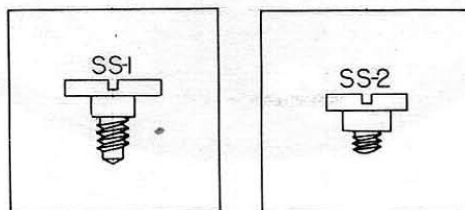

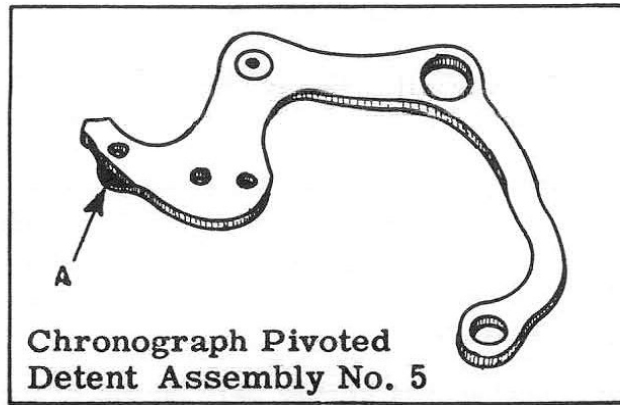

### OILING

The eccentric stud that the chronograph pivoted detent pivots on should be slightly moistened with oil.



5A

## PART NO. 6

### A. DISASSEMBLY PROCEDURE OF ACTUATING DETENT LEVER SPRING:

This spring is held in place by beveled countersink screw BS-2 and a steady pin. After screw is removed, the spring may be loosened from plate, by sliding a thin blade screwdriver between plate and spring. When steady pin is free in plate, this spring can be lifted out of place.

NOTE: You will notice this spring sets on top of a small plate shown as "B" in the isometric drawing. This small plate holds the spring above the level of the movement plate.

(The shape of screw for this part is shown at bottom of page.)

### B. ASSEMBLY PROCEDURE OF ACTUATING DETENT LEVER SPRING:

Place this spring in its proper position on the movement, as shown in the photograph. The steady pin on spring must pass through the plate "B" into the proper hole in the movement. Now press this spring down to proper place. Before replacing screw, make sure the end "A" is in contact with the pin "C" on joint hook, as shown in the photograph. Beveled countersink screw BS-2 can now be replaced.

REF: Actuating Detent Lever and Joint Hook is Assembly 7.

### C. FUNCTION OF ACTUATING DETENT LEVER SPRING:

The function of this spring is to do three things:

1. It holds the joint hook in toward the center of the watch.
2. It holds a tension on joint hook holding it engaged with the ratchet teeth on the castle wheel.
3. It helps hold joint hook down flush on plate.

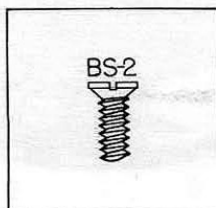



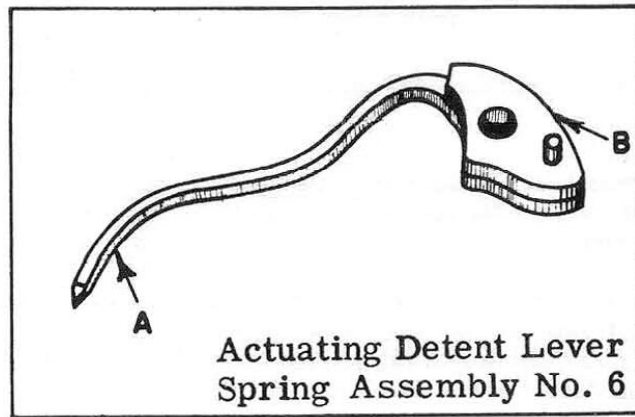

### OILING

End "A" on actuating detent lever spring should be slightly moistened with oil at point of contact with pin "B" on joint hook.

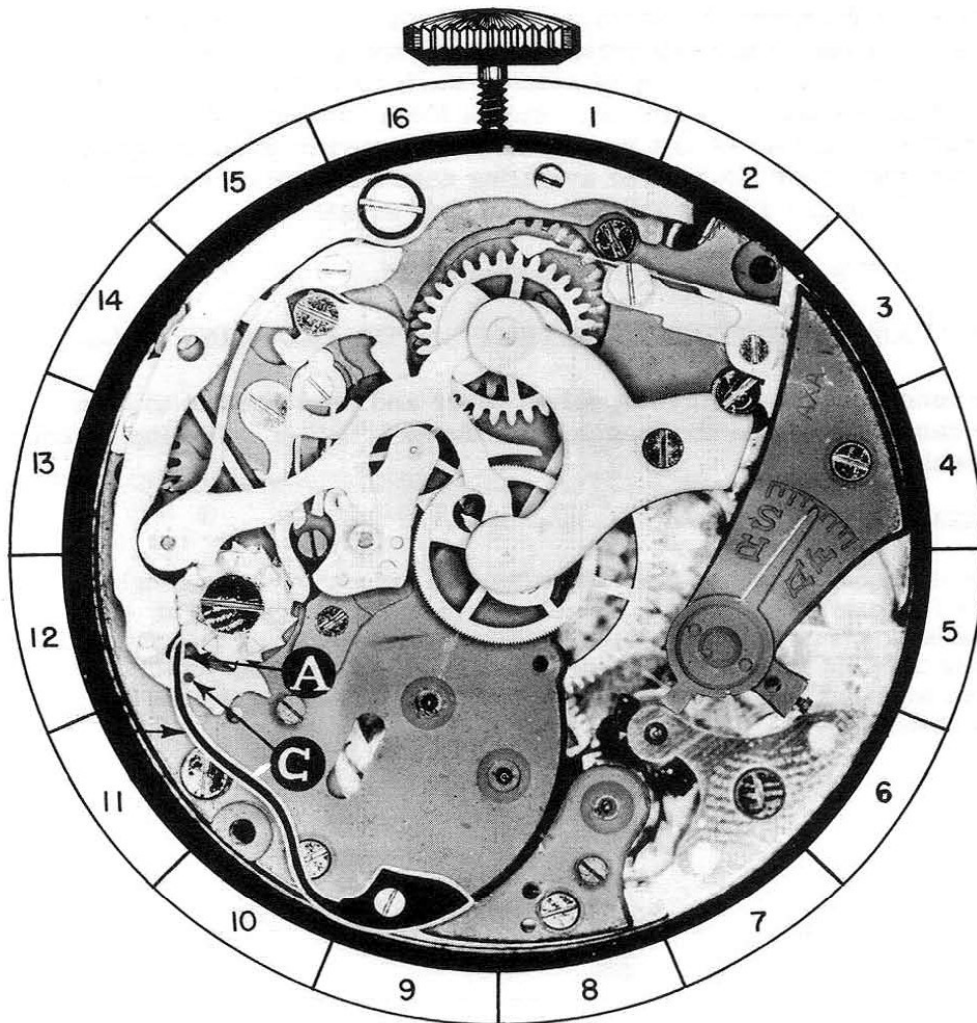

6A

## PART NO. 7

### A. DISASSEMBLY PROCEDURE OF ACTUATING DETENT LEVER AND JOINT HOOK:

The actuating detent lever is held in place by shouldered screw SS-3 and pivots on this screw. When screw is removed, detent lever may be lifted from movement.

NOTE: The joint hook is held to the actuating detent lever by shouldered screw SS-4. To remove the joint hook from the actuating detent lever, remove shouldered screw SS-4. This will free the joint hook from the actuating detent lever.

(The shape of screws for this part is shown at the bottom of page.)

### B. ASSEMBLY PROCEDURE OF ACTUATING DETENT LEVER AND JOINT HOOK:

Place the joint hook on the actuating detent lever and replace shouldered screw SS-4 that holds the joint hook to the actuating detent lever. Check joint hook to see that it pivots freely under head of screw. Now place the actuating detent lever and joint hook in proper position on plate as shown in photograph. Before replacing screw, be sure that joint hook is not on top of ratchet teeth on castle wheel. The joint hook should mesh into the ratchet teeth on castle wheel. When actuating detent lever and joint hook are in proper position, replace shouldered screw SS-3. The actuating detent should be checked to see that it pivots freely under head of this screw.

REFERENCE: Castle wheel is Assembly 17.

### C. FUNCTION OF ACTUATING DETENT LEVER AND JOINT HOOK:

The function of the actuating detent lever and joint hook is to turn the castle wheel one tooth each time the end "B" of actuating detent is pushed.

#### REMARKS:

The joint hook should be carefully examined for any burrs or roughness that may cause it not to function properly. The end "A" of joint hook should be highly polished, as any burrs or roughness may cause the joint hook not to engage properly with the ratchet teeth. When polishing this part, care should be taken that shape of hook is not changed.

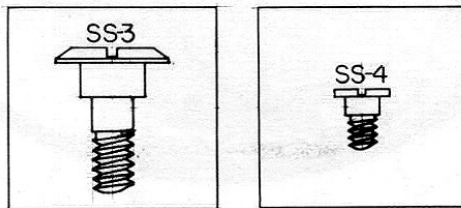

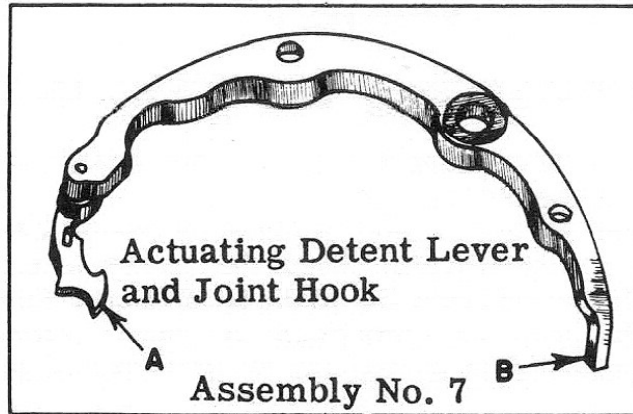

### OILING

These two points on actuating detent lever and joint hook should be slightly moistened with oil:

1. Shoulder of screw that actuating detent pivots on.
2. Shoulder of screw that joint hook pivots on.

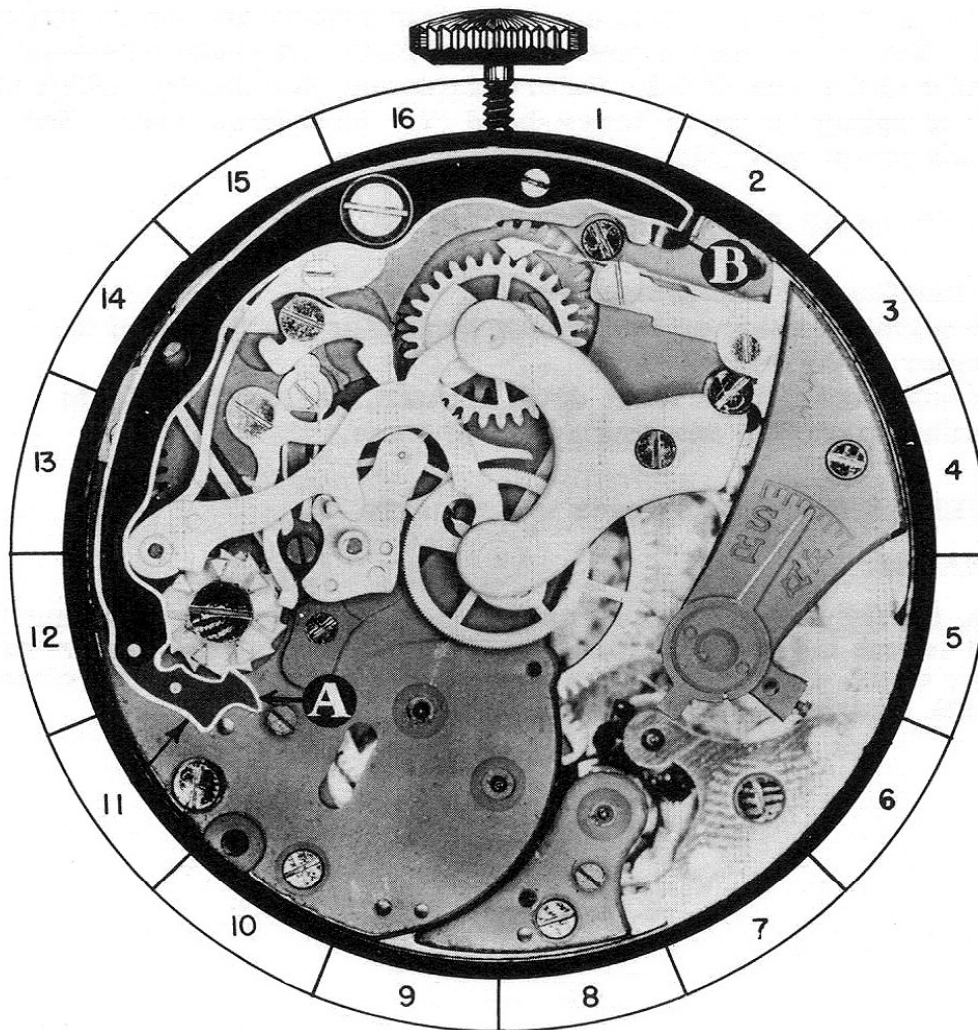

7A

## PART NO. 8

### A. DISASSEMBLY PROCEDURE OF FLYBACK LEVER SPRING:

(Before removing this spring make sure the flyback lever is in the position shown in the photograph.)

The flyback lever spring is held in place by beveled countersink screw B S -3 and a steady pin. When this screw is removed, this spring can be loosened from the plate by sliding a thin blade screw-driver between the spring and the plate. After steady pin is free in hole in plate, this spring can be lifted out of place.

**REFERENCE:** Flyback lever is Assembly 11.

(The shape of screw for this part is shown at the bottom of page.)

### B. ASSEMBLY PROCEDURE OF FLYBACK LEVER SPRING:

Before replacing this spring, make sure the flyback lever is in the position shown in the photograph. When this is done, place this spring in its proper position on the plate, with steady pin in proper hole. Now press spring down flush on plate, and replace beveled countersink screw B S-3. Before tightening this screw, hook end "A" of spring on top of screw-head "C" on flyback lever. Now tighten screw that holds this spring in place.

### C. FUNCTION OF FLYBACK LEVER SPRING:

The functions of this spring are:

1. It holds a tension on the flyback lever, forcing it toward the center of the watch.
2. It holds the flyback lever down in place, preventing it from riding up on post and coming out of place.

**REFERENCE:** Flyback lever is Assembly 11.

#### REMARKS:

When the flyback lever is released, the flyback lever spring must hold enough tension on flyback lever to force it toward the center of the watch with enough pressure to return the seconds wheel and minute register wheel to a zero position.

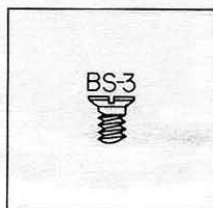



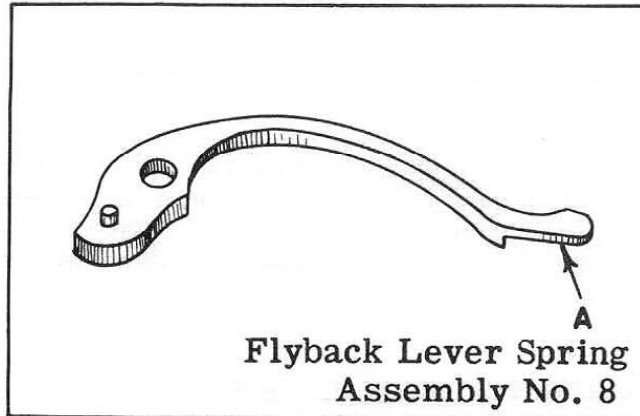

Flyback Lever Spring  
Assembly No. 8

### OILING

End "A" on flyback lever spring should be slightly moistened with oil at point of contact with flyback lever.

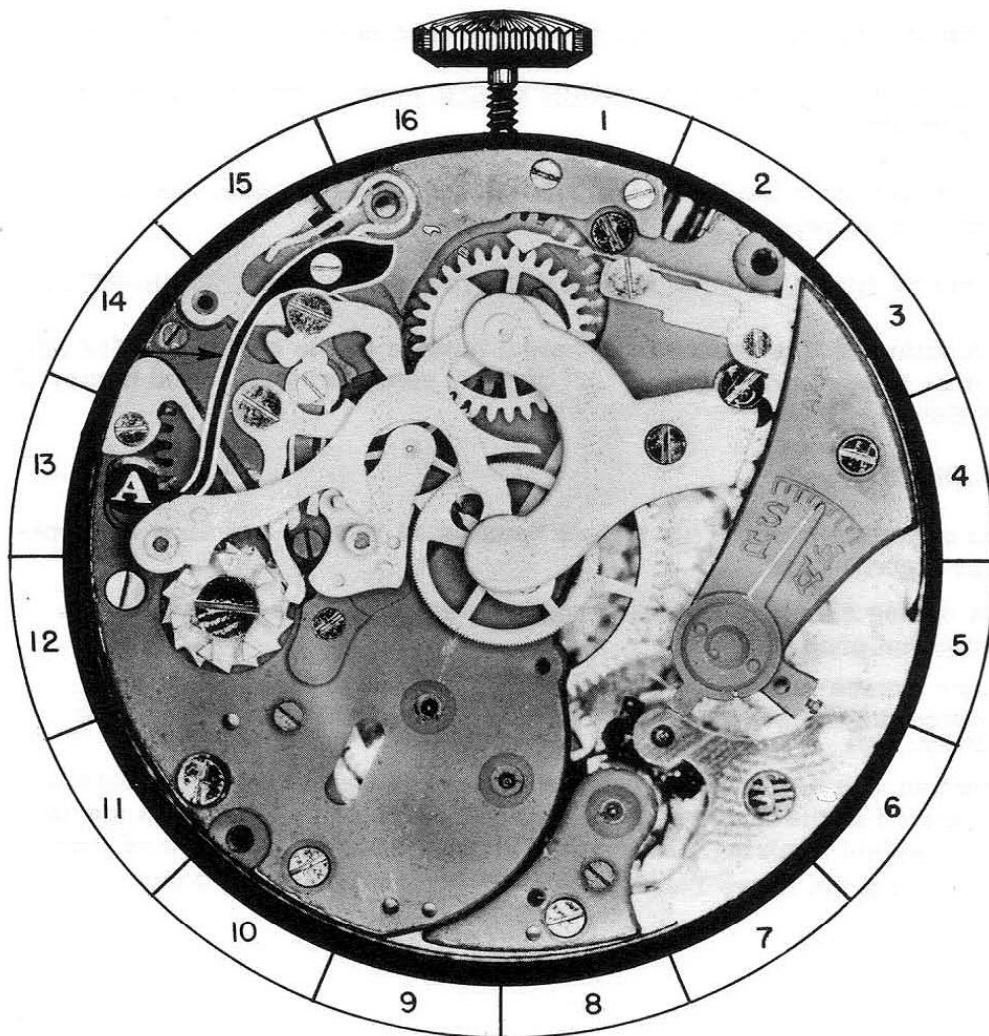

8A

## PART NO. 9

### A. DISASSEMBLY PROCEDURE OF PUSH PIECE FOR SETTING BACK TO ZERO SPRING:

Grip end "A" of spring with a pair of tweezers. Lift up, freeing it from the push piece for setting back to zero. After tension has been removed, it can be lifted from the hollow stud on the plate. When removing this spring, hold your finger over it to eliminate the hazard of it shooting away and becoming lost.

### B. ASSEMBLY PROCEDURE OF PUSH PIECE FOR SETTING BACK TO ZERO SPRING:

Place end "B" of spring in its proper position on the plate, as shown in the photograph. Now grip end "A" of spring with a pair of tweezers and force end "A" of spring in toward the center of the watch, hooking it on the inside of the push piece for setting back to zero. Hold finger over end "B" of spring when forcing end "A" of spring toward the center of the watch, to eliminate the hazard of the spring shooting away and becoming lost.

REFERENCE: Push piece for setting back to zero is Assembly 10.

### C. HAZARDS IN ASSEMBLY OF PUSH PIECE FOR SETTING BACK TO ZERO SPRING:

To help eliminate the hazard of this spring shooting away, use a sturdy pair of tweezers when replacing this spring.

### D. FUNCTION OF PUSH PIECE FOR SETTING BACK TO ZERO SPRING:

The function of this spring is to hold a tension on the push piece for setting back to zero, holding end "A" of push piece away from the center of the watch.

#### REMARKS:

When adjusting springs for proper tension, it is good to follow this policy as a general rule.

1. A spring should just hold enough tension on a part to perform its function properly.
2. Any excess tension on a part in a chronograph mechanism will cause the chronograph to be harder to work, also causing more wear, etc.

Of course, the amount of pressure the spring should hold on a part is determined in the factory; because of this it is seldom that you should have to adjust a spring. However, you may have to make one of these springs, and the above rules should aid you in setting the proper tension.

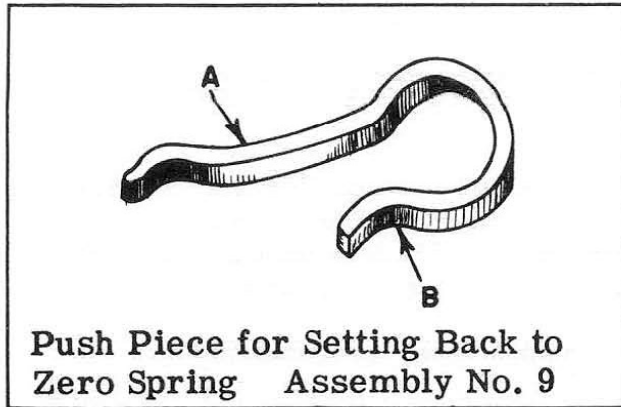

### OILING

End "A" of push piece for setting back to zero spring should be slightly moistened with oil at point of contact with push piece for setting back to zero.

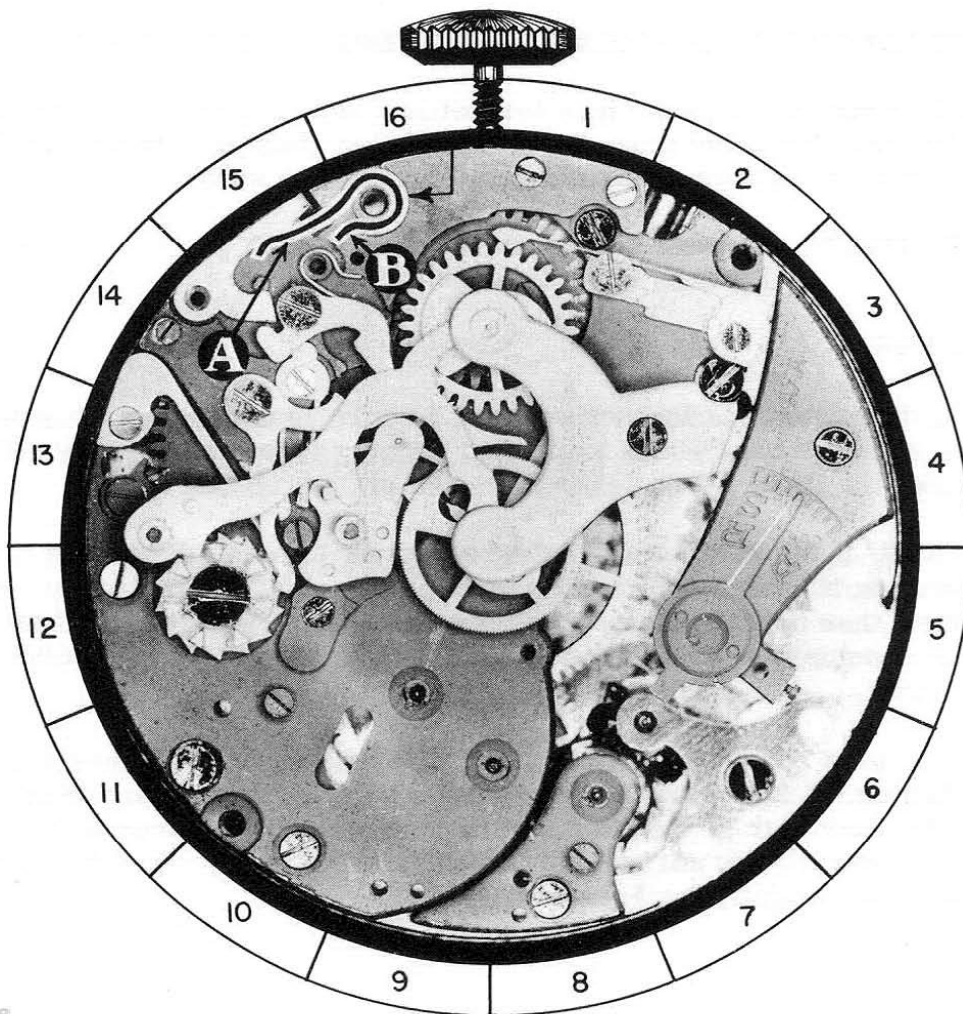

9A

PART NO. 10

**A. DISASSEMBLY PROCEDURE OF PUSH PIECE FOR SETTING BACK TO ZERO:**

Before removing this push piece, check to see that the flyback lever is all the way toward the center of the watch, as far as it will go as shown in the photograph. To remove this push piece, simply lift push piece from the hollow stud on plate.

**REFERENCE:** Flyback lever is Assembly 11.

**B. ASSEMBLY PROCEDURE OF PUSH PIECE FOR SETTING BACK TO ZERO:**

Before replacing this push piece, make sure that the flyback lever is in toward the center of the watch, as shown in the photograph. Now place the push piece for setting back to zero in its proper position on the plate, as shown in the photograph. The hole in this push piece should fit over a hollow stud on the plate.

**C. FUNCTION OF PUSH PIECE FOR SETTING BACK TO ZERO:**

The function of the push piece for setting back to zero is to unhook the flyback trip lever from the flyback lever thus permitting the flyback lever to be forced toward the center of the watch.

**REFERENCE:** Flyback trip lever is Assembly 12.  
Flyback lever is Assembly 11.

**REMARKS:**

When the push piece for setting back to zero is depressed, this push piece contacts the flyback trip lever forcing it to turn slightly. This unhooks the flyback trip lever from the pin on flyback lever.

**NOTICE:** If the head of a shouldered screw tightens down on a part, preventing it from functioning properly, the shoulder of the screw is shorter than the thickness of the lever. To correct this, the head of the shouldered screw must be cut back to lengthen the shoulder on the screw.

I do not want to give the impression that lengthening the shoulder on shouldered screw will always free a part under it, many times it is the diameter of the shoulder that is causing the lever to be tight. Naturally, to correct this, the diameter of the shoulder must be cut down slightly for freedom.



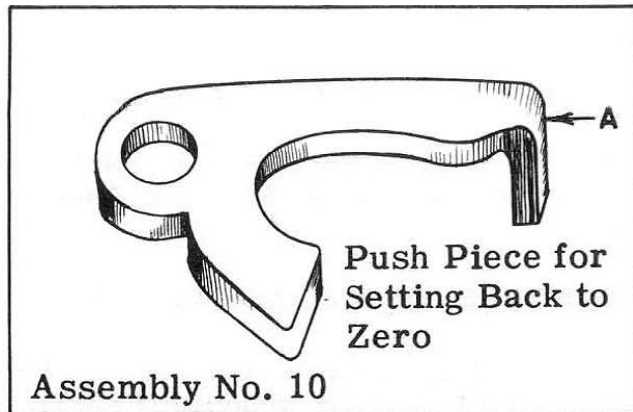

### OILING

These points on push piece for setting back to zero should be slightly moistened with oil:

1. The post that push piece pivots on.
2. Point "B" on push piece that contacts flyback trip lever.

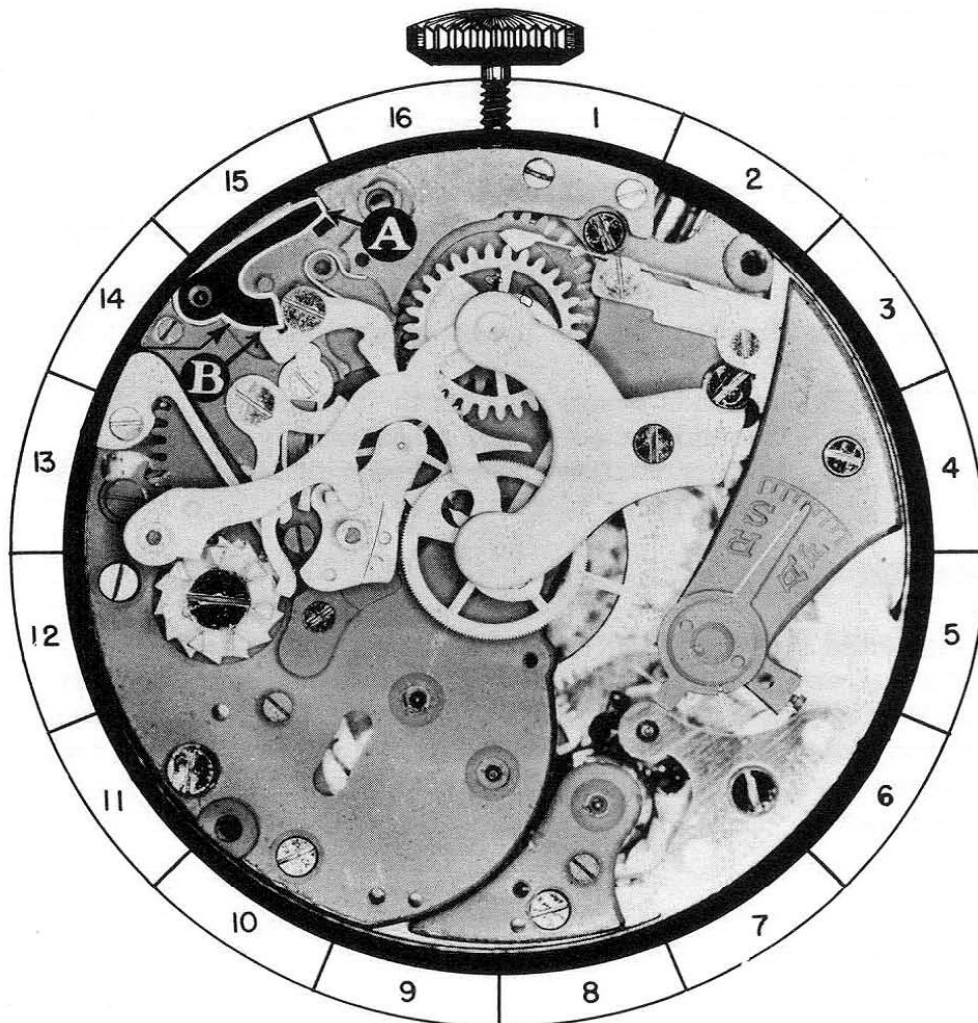

10A

## PART NO. 11

### A. DISASSEMBLY PROCEDURE OF FLYBACK LEVER:

To remove the flyback lever, place it in the position shown in photograph. Now lift straight up on the lever, freeing it from the post on plate.

### B. ASSEMBLY PROCEDURE OF FLYBACK LEVER:

The flyback lever should be replaced with the screw-head "C" down. Now place the flyback lever in position shown in photograph, with the hole in bushing over post on plate. Now press the flyback lever down and make sure that the pin "D" on flyback lever is not on top of the flyback trip lever. If this pin sets on top of the flyback trip lever, move the flyback trip lever away from this pin, permitting the flyback lever to be pressed down further into place.

REFERENCE: Flyback trip lever is Assembly 12.

### C. FUNCTION OF FLYBACK LEVER:

The functions of the flyback lever are:

1. It disengages the intermittent wheel from the seconds wheel dart tooth.
2. The ends "A" and "B" of flyback lever contact the heart on the seconds wheel and minute register wheel forcing these wheels to return to a zero position.
3. The pin "E" on flyback lever contacts the surface "C" on brake lever disengaging the brake lever from seconds wheel.

REFERENCE: Seconds wheel dart tooth is Assembly 21-C.  
Seconds wheel heart is Assembly 21-B.  
Minute register wheel heart is Assembly 23-B.  
Brake lever is Assembly 14.

### REMARKS:

The flat ends "A" and "B" of flyback lever must be highly polished as any roughness or pits of rust at this location may cause the flyback lever not to function properly. When polishing these ends, care should be taken as not to shorten one end more than the other or they will not function correctly as described above.

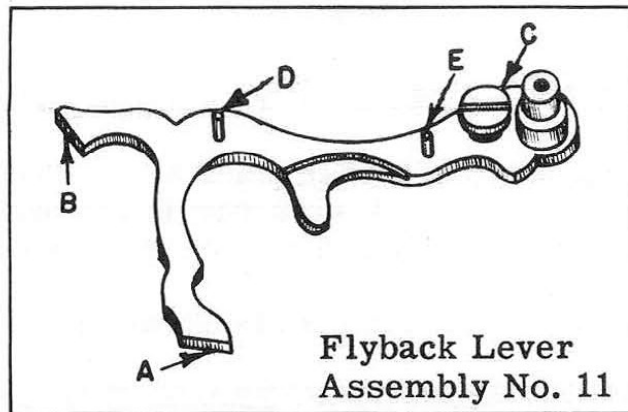

These points on flyback lever should be slightly moistened with oil:

1. Post on which flyback lever pivots
2. Pin "D" at point of contact with flyback trip lever
3. Pin "E" at point of contact with point "C" on brake lever
4. Point "F" at point of contact with pin "C" on intermittent lever.

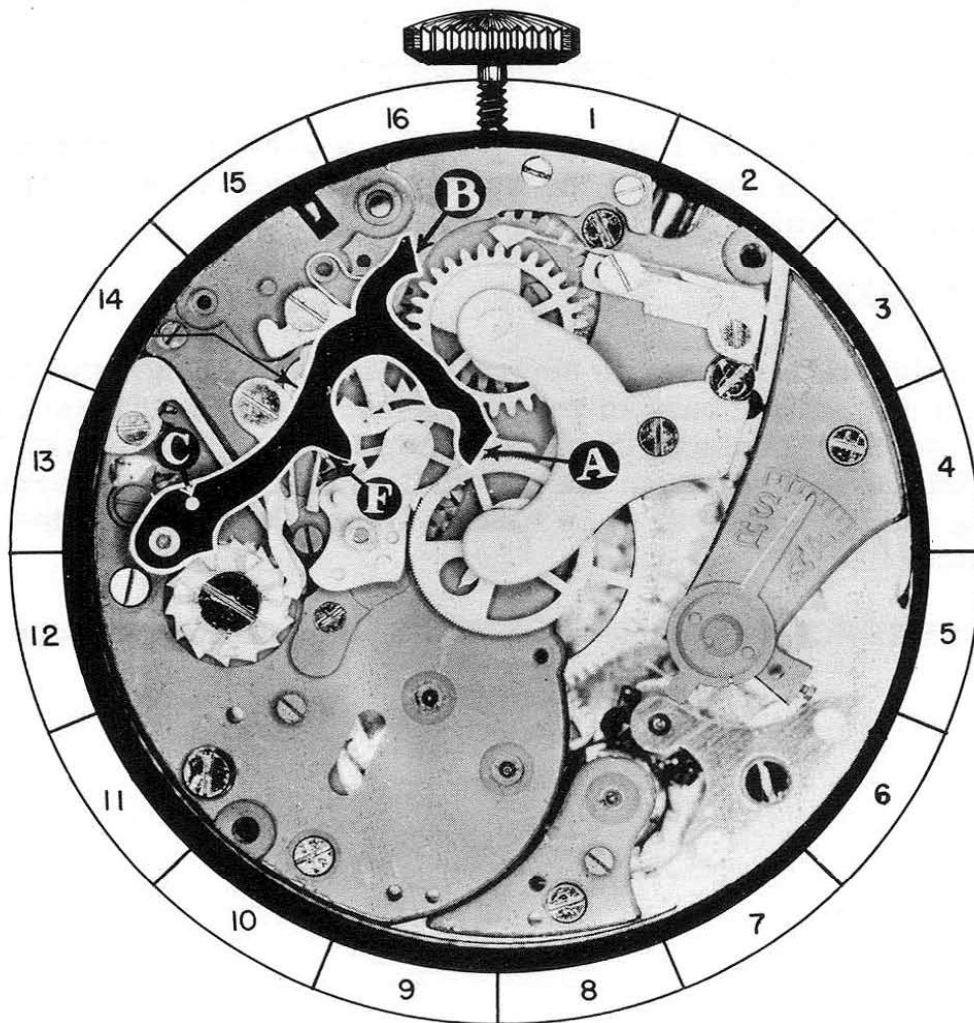

11A

## PART NO. 12

### A. DISASSEMBLY PROCEDURE OF FLYBACK TRIP LEVER:

The flyback trip lever is held in place by shouldered screw SS-5 and pivots on this screw. When screw is removed, this trip lever will be free on plate, and may be lifted out of place.

(The shape of screw for this part is shown at bottom of page.)

### B. ASSEMBLY PROCEDURE OF FLYBACK TRIP LEVER:

Place this lever on the plate, in the position shown in the photograph, with the pin "A" on the trip lever, on the outside surface of "A" of the flyback trip lever spring. Now replace shouldered screw SS-5 to hold this part in place. The trip lever should pivot freely under the head of this screw.

REFERENCE: Flyback trip lever spring is Assembly 13.

### C. FUNCTION OF FLYBACK TRIP LEVER:

The function of the flyback trip lever is to hold the flyback lever away from the center of the watch and release it, when the push piece for setting back to zero is pushed.

#### REMARKS:

The flyback trip lever is controlled manually. When the push piece for setting back to zero is pushed in toward the center of the watch, it contacts the flyback trip lever. This unlocks the flyback trip lever from the pin "D" on flyback lever, permitting the flyback lever to be forced toward the center of the watch.

REFERENCE: Push piece for setting back to zero is Assembly 10.

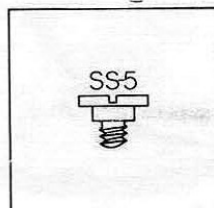



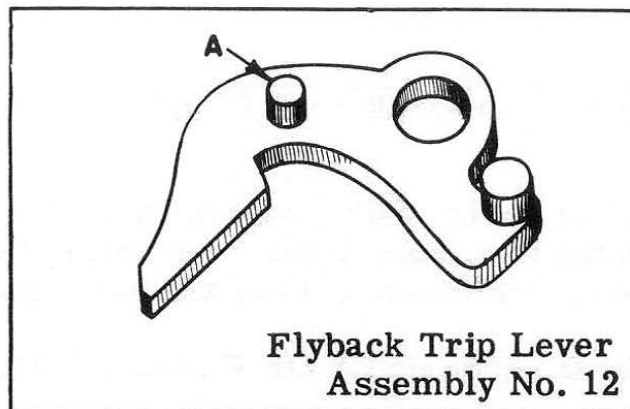

Flyback Trip Lever  
Assembly No. 12

### OILING

The flyback trip lever should be slightly moistened with oil at these points:

1. Shoulder of screw that flyback trip lever pivots on.
2. Pin "A" that contacts flyback trip lever spring.

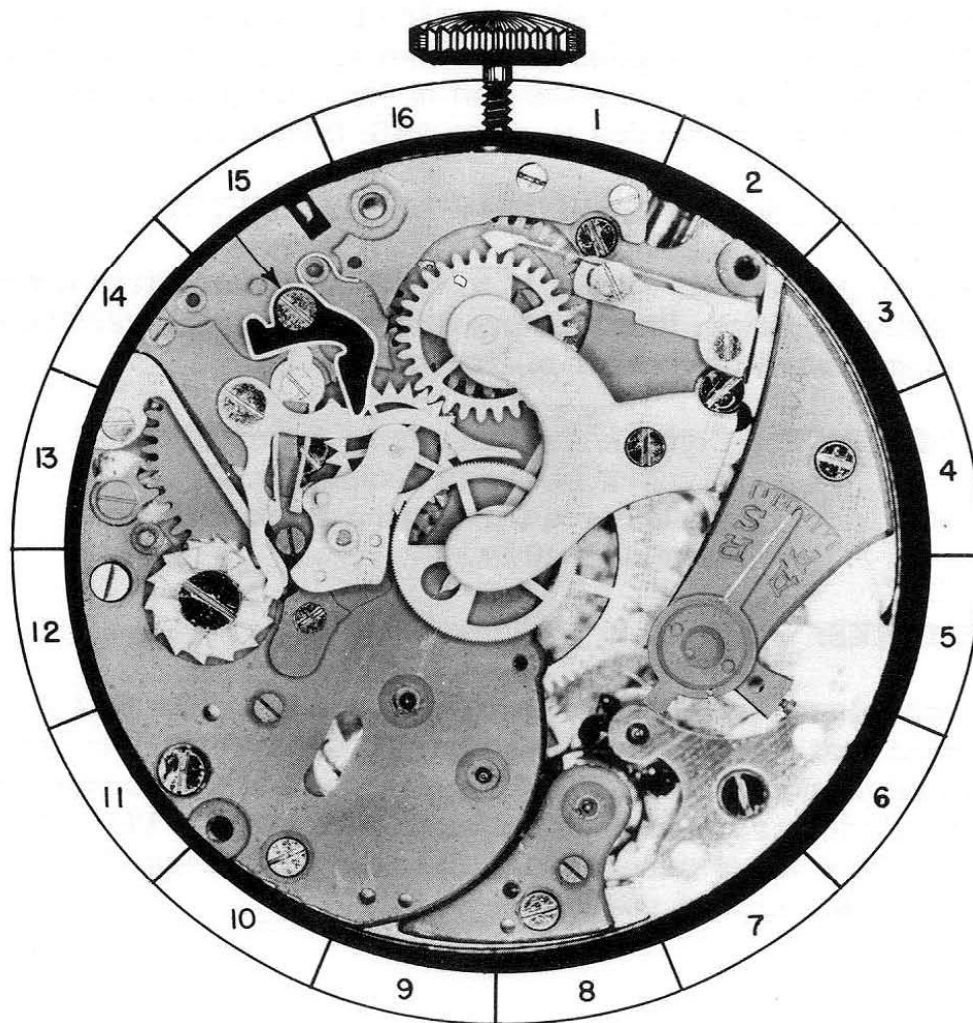

12A

## PART NO. 13

### A. DISASSEMBLY PROCEDURE OF FLYBACK TRIP LEVER SPRING:

Grip end "A" of spring with a pair of tweezers, and lift up on spring. In doing this, hold finger over spring to eliminate the hazard of the spring shooting away and becoming lost.

### B. HAZARDS IN DISASSEMBLY OF FLYBACK TRIP LEVER SPRING:

This spring is very delicate and care should be taken so as not to bend this spring in any way.

### C. ASSEMBLY PROCEDURE OF FLYBACK TRIP LEVER SPRING:

Grip end "A" of spring with a pair of tweezers and place end "B" of spring in its proper position as shown in the photograph. Hold finger over the end of the spring and force the end "A" down in recess in plate with tweezers.

### D. FUNCTION OF FLYBACK TRIP LEVER SPRING:

The function of this spring is to hold the flyback trip lever in a locking position, that will prevent the flyback lever from moving toward the center of the watch.

REFERENCE: Flyback Trip Lever is Assembly 12.  
Flyback Lever is Assembly 11.  
Push Piece for Setting Back to Zero is Assembly 10.

### REMARKS:

At this place, I would like to remind the repairer that it is important that in removing these parts, the screwdriver and tweezers should be sharpened correctly and the correct size of screwdriver blade used for each screw slot. This will eliminate a lot of unnecessary breakage, marring of plates or screws, and loss of parts.

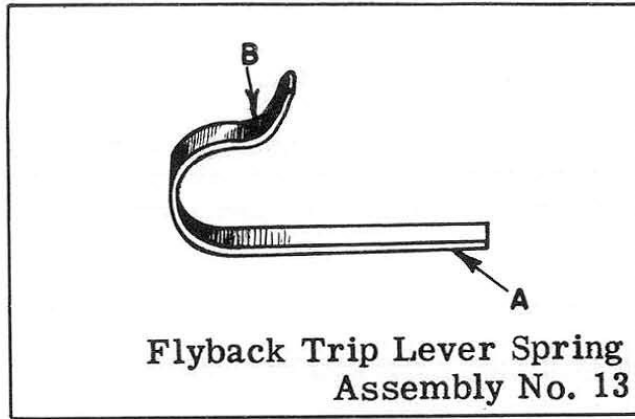

### OILING

The flyback trip lever spring should not be oiled.

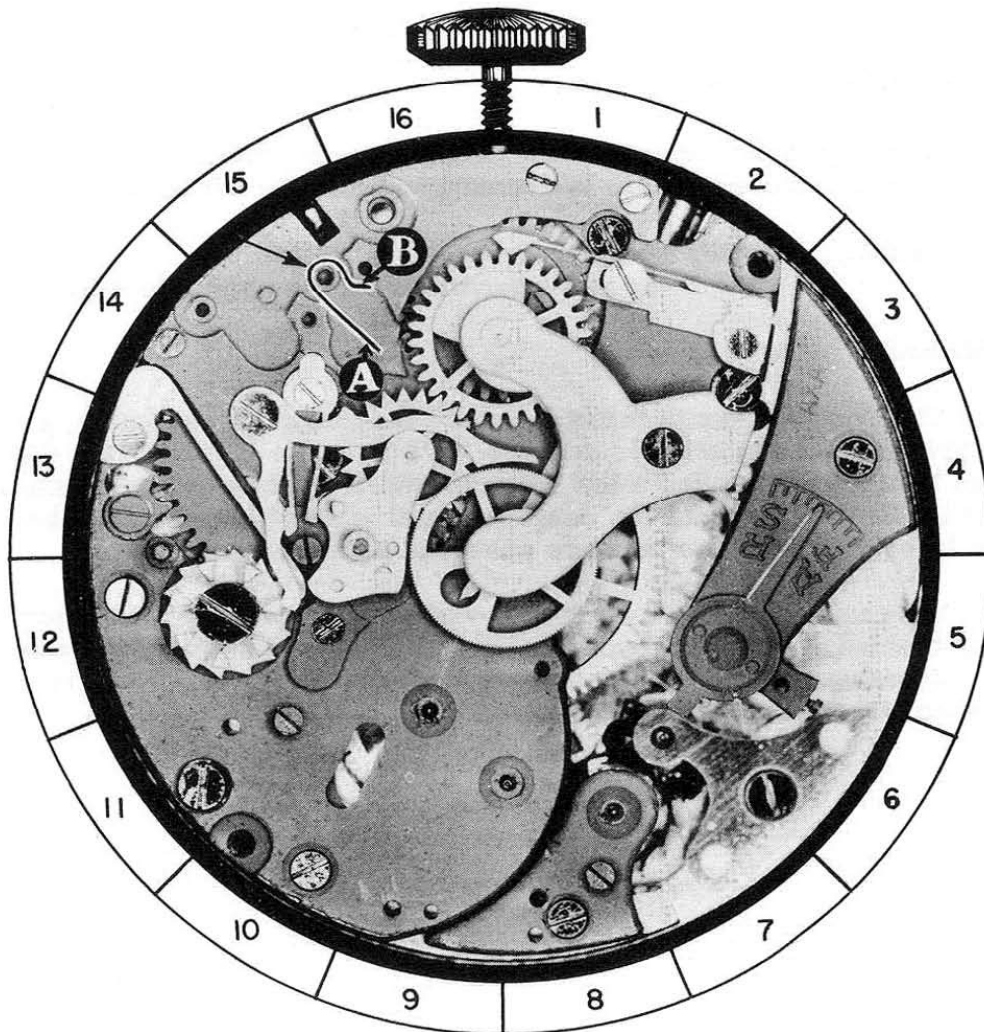

13A

## PART NO. 14

### A. DISASSEMBLY PROCEDURE OF BRAKE LEVER:

This brake lever is held in place by shouldered screw SS-6 and pivots on this screw. After this screw is removed, do not lift straight up on brake lever, but slide the lip "A" on it from under the brake lever and intermittent lever spring.

(The shape of screw for this part is shown at the bottom of the page.)

### B. HAZARDS IN DISASSEMBLY OF BRAKE LEVER:

Hold finger over lever when removing screw, so that screw does not shoot away and become lost.

### C. ASSEMBLY PROCEDURE OF BRAKE LEVER:

Place the brake lever on plate in its proper position. The lip "A" on the brake lever should fit under end "B" of brake lever and intermittent lever spring. Now place hole in brake lever over proper hole in plate, and replace shouldered screw SS-6. Check the brake lever to see that it pivots freely under the head of this screw.

### D. FUNCTION OF BRAKE LEVER:

Function of the brake lever is to hold the seconds wheel stationary, when the intermediary wheel is disengaged from the seconds wheel.

REFERENCE: Seconds wheel is Assembly 21.

Brake lever and intermittent lever spring is Assembly 15.

### REMARKS:

When the flyback lever is brought toward the center of the watch, pin "E" on flyback lever contacts the surface "C" on brake lever. This disengages the brake lever from the seconds wheel. Naturally, the brake lever must be disengaged from the seconds wheel at this time, so that the flyback lever can bring the seconds wheel back to zero position.

When the castle wheel is turned to a position to permit the intermediary wheel to engage with the seconds wheel, the castle wheel at the same time disengages the brake lever from the seconds wheel. This frees the seconds wheel so that it can turn.

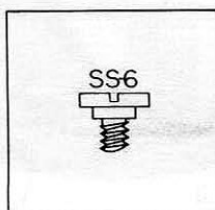



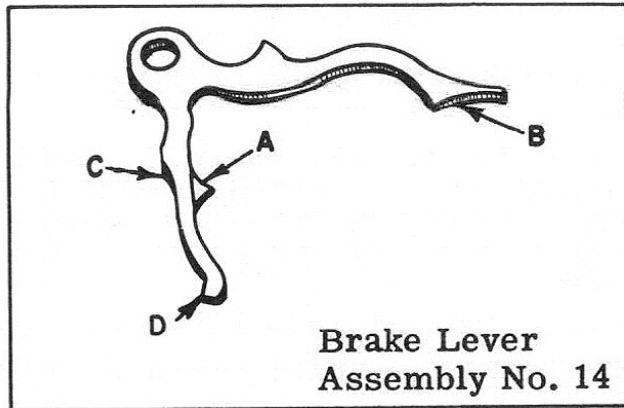

### OILING

The brake lever should be slightly moistened with oil at these points:

1. The shoulder of screw on which brake lever pivots
2. Point "A" that contacts end "B" on brake lever spring.

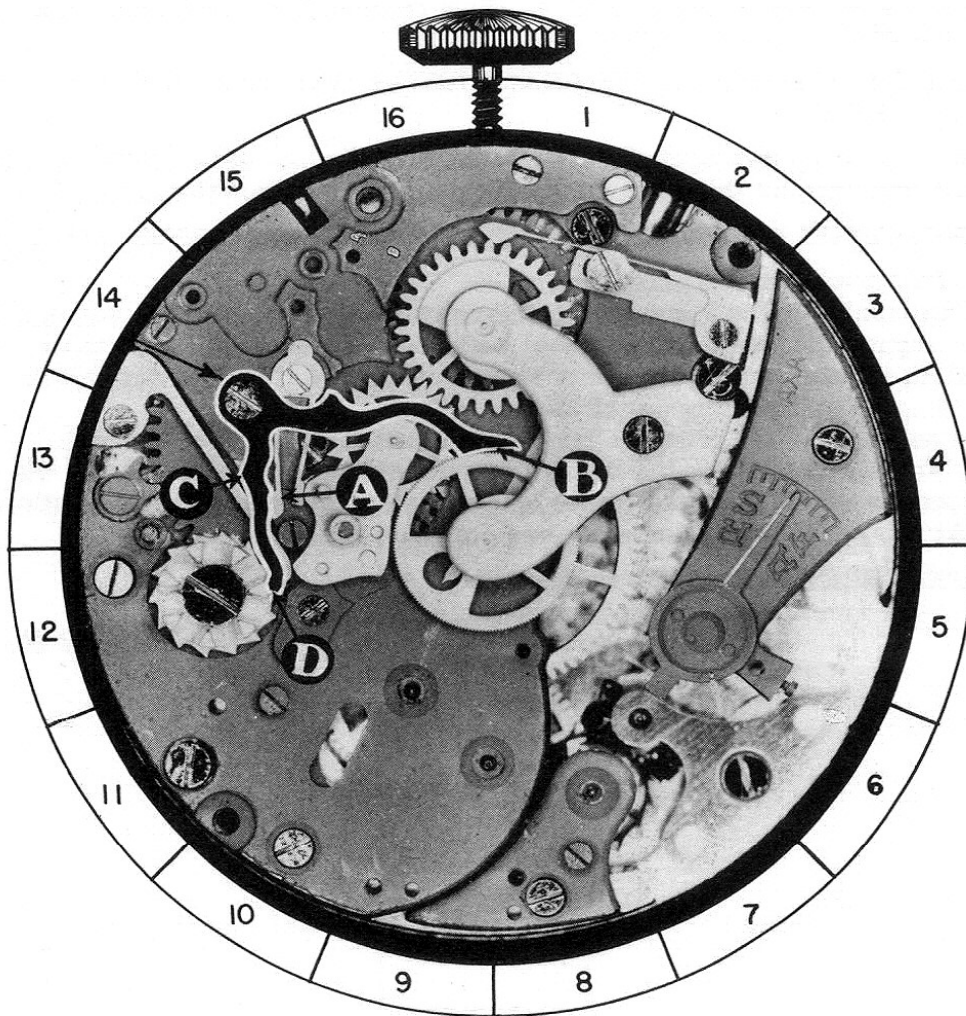

14A

## PART NO. 15

### A. DISASSEMBLY PROCEDURE OF BRAKE LEVER AND INTERMITTENT LEVER SPRING:

This spring is held in place by fillister screw FS-2 and a recess in the plate. To remove this spring, remove fillister screw FS-2 and slide a finely-sharpened screwdriver under the base of the spring loosening it from the recess in the plate. After spring is free on plate, spring can be lifted out of place.

(The shape of screw for this part is shown at bottom of page.)

### B. HAZARDS IN DISASSEMBLY OF BRAKE LEVER AND INTERMITTENT LEVER SPRING:

This spring is very delicate and can be very easily damaged. If the shape of this spring is changed in any way, this spring may not function properly.

### C. ASSEMBLY PROCEDURE OF BRAKE LEVER AND INTERMITTENT LEVER SPRING:

Place the brake lever and intermittent lever spring in its proper position on plate as shown in the photograph. This spring fits down in the recess in the plate. Place the end "A" of this spring on the lip "A" of the intermittent lever and wheel assembly. Now replace fillister head screw FS-2 that holds this spring in place.

### D. HAZARDS IN ASSEMBLY OF BRAKE LEVER AND INTERMITTENT LEVER SPRING:

When replacing this spring, care should be taken not to bend this spring in any manner, as this may cause the spring not to function properly.

### E. FUNCTION OF BRAKE LEVER AND INTERMITTENT LEVER SPRING:

The functions of this spring are:

1. This spring holds a tension on intermittent lever and wheel assembly to engage the intermittent wheel with the seconds wheel dart tooth. Also, it holds the intermittent lever down on post preventing it from riding up and coming out of place.
2. It holds end "D" of brake lever in contact with the castle wheel.
3. It holds a tension on the brake lever forcing end "B" to contact the seconds wheel when the brake lever is not disengaged by the castle wheel. (At this point the brake lever has not been assembled.)

REFERENCE: Brake lever is Assembly 14.

Castle wheel is Assembly 17.

Intermittent lever and wheel assembly is Assembly 24.

Intermittent wheel is shown on page 24-C.

Seconds wheel dart tooth is Assembly 21-C.

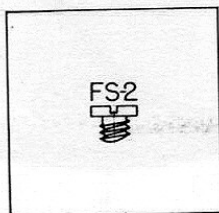

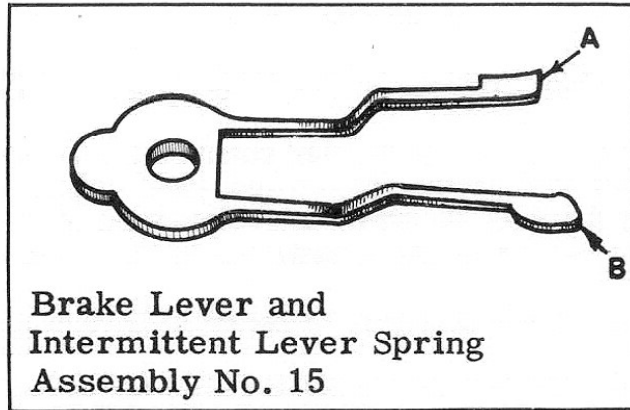

### OILING

End "A" on brake lever and intermittent lever spring should be slightly moistened with oil at point of contact with intermittent lever.

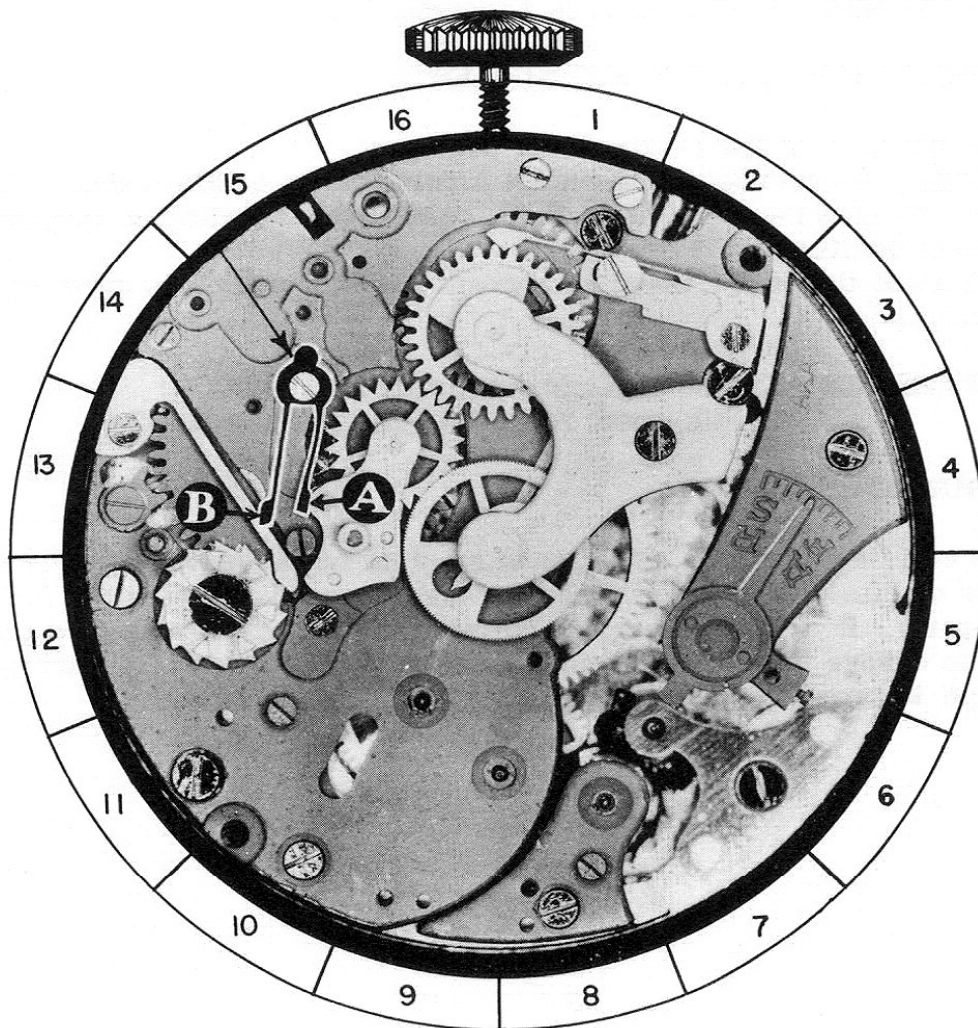

15A

PART NO. 16

**A. DISASSEMBLY PROCEDURE OF CASTLE WHEEL PAWL:**

This pawl is held in place by beveled countersink screw BS-4 and a steady pin. When this screw is removed, pawl can be loosened from plate by sliding a thin blade screwdriver between pawl and plate. After steady pin is free in plate, pawl can be lifted out of place.

(The shape of screw for this part is shown at bottom of page)

**B. ASSEMBLY PROCEDURE OF CASTLE WHEEL PAWL:**

Place pawl in its proper position on plate, with steady pin in proper hole in plate. Now press pawl down flush on plate. Make sure that end "A" of pawl is not on top of the ratchet teeth on the castle wheel but meshing in between two of the teeth on this wheel. To function properly, the end "A" of pawl must be engaged with the ratchet teeth on castle wheel. Now replace beveled countersink screw BS-4 that holds this pawl in place.

**REFERENCE:** Castle wheel is Assembly 17.

**C. FUNCTION OF CASTLE WHEEL PAWL:**

The functions of the castle wheel pawl are:

1. This pawl correctly spaces the turning of the castle wheel. This eliminates the possibility of the castle wheel setting at an incorrect position.
2. It holds the castle wheel in correct position until it is moved manually.

**REFERENCE:** Castle wheel is Assembly 17.  
Castle wheel ratchet teeth is Assembly 17 B.

**REMARKS:**

The end "A" of castle wheel pawl must be highly polished. Any roughness or pits of rust at this location may cause the pawl not to function properly. If it is necessary to polish this part, care should be taken not to change the shape of end "A" of pawl. It must be of correct shape to properly space the turning of the castle wheel.

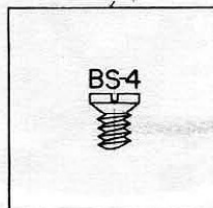



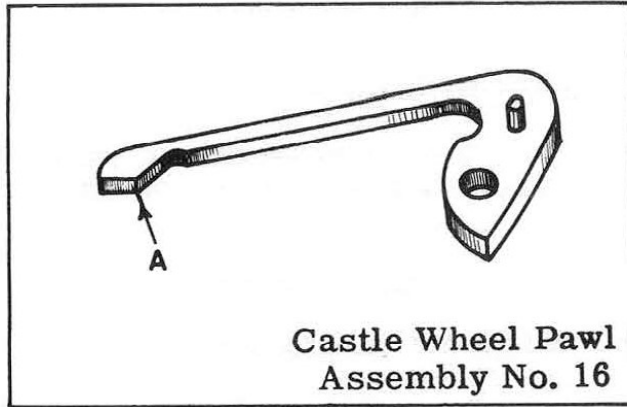

### OILING

The castle wheel pawl should not be oiled.

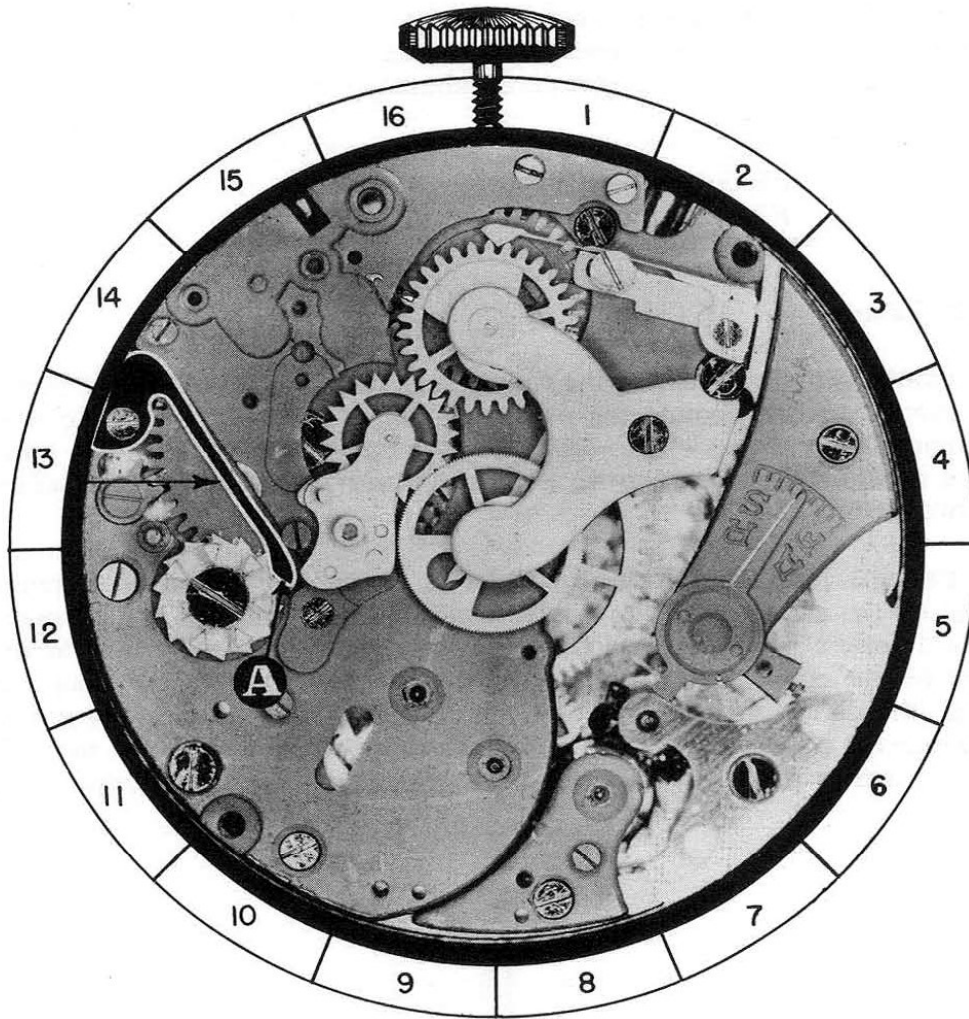

16A

## PART NO. 17

### A. DISASSEMBLY PROCEDURE OF CASTLE WHEEL:

The castle wheel is held in place by shouldered screw SS-7. After this screw is removed, castle wheel will be free on plate and can be lifted out of place.

(The shape of screw for this part is shown at bottom of page.)

### B. ASSEMBLY PROCEDURE OF CASTLE WHEEL:

Place the castle wheel in its proper position on plate as shown in the photograph. Replace shouldered screw SS-7 that holds this wheel in place. Check to see that wheel turns freely under the head of this screw. Of course, this wheel should not have excessive freedom.

### C. FUNCTION OF CASTLE WHEEL:

The functions of the castle wheel are:

1. It disengages the intermediary wheel from the seconds wheel.
2. It disengages the brake lever from the seconds wheel.
3. It prevents the flyback lever from being moved toward the center of watch when the chronograph mechanism is engaged.

**REFERENCE:** Intermediary wheel is Assembly 4.  
Seconds wheel is Assembly 21.  
Flyback lever is Assembly 11.  
Brake lever is Assembly 14.

### REMARKS:

The castle wheel performs its function by the "columns" "A" which are evenly spaced around the center of the wheel. As the castle wheel is turned, the column either forces a part to move out from the center of the castle wheel or permits it to move into the empty space between the two columns.

For example, the intermediary wheel is disengaged from the seconds wheel by the columns of the castle wheel forcing the end of chronograph pivoted detent from between the columns until the point of this lever rests on the column. To engage the intermediary wheel with the seconds wheel, the castle wheel is turned one space. This permits the end of chronograph pivoted detent to enter the empty space between the columns which permits the two wheels to be engaged by the chronograph pivoted detent.

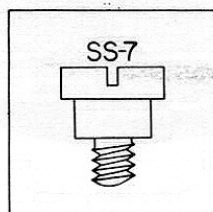

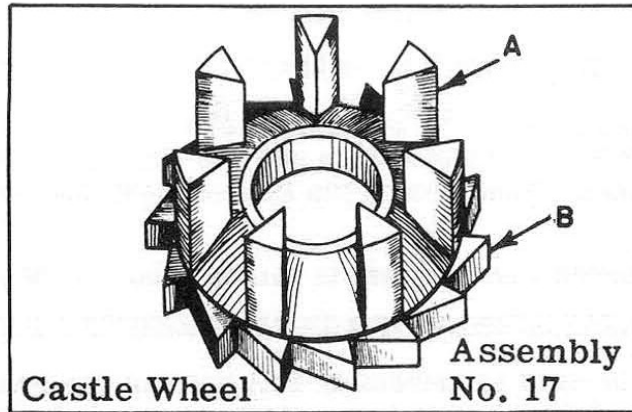

### OILING

The castle wheel should be slightly moistened with oil on the following points:

1. The shoulder of screw on which the castle wheel pivots.
2. The columns "A" that contact the parts of the chronograph mechanism.
3. The ratchet teeth "B".

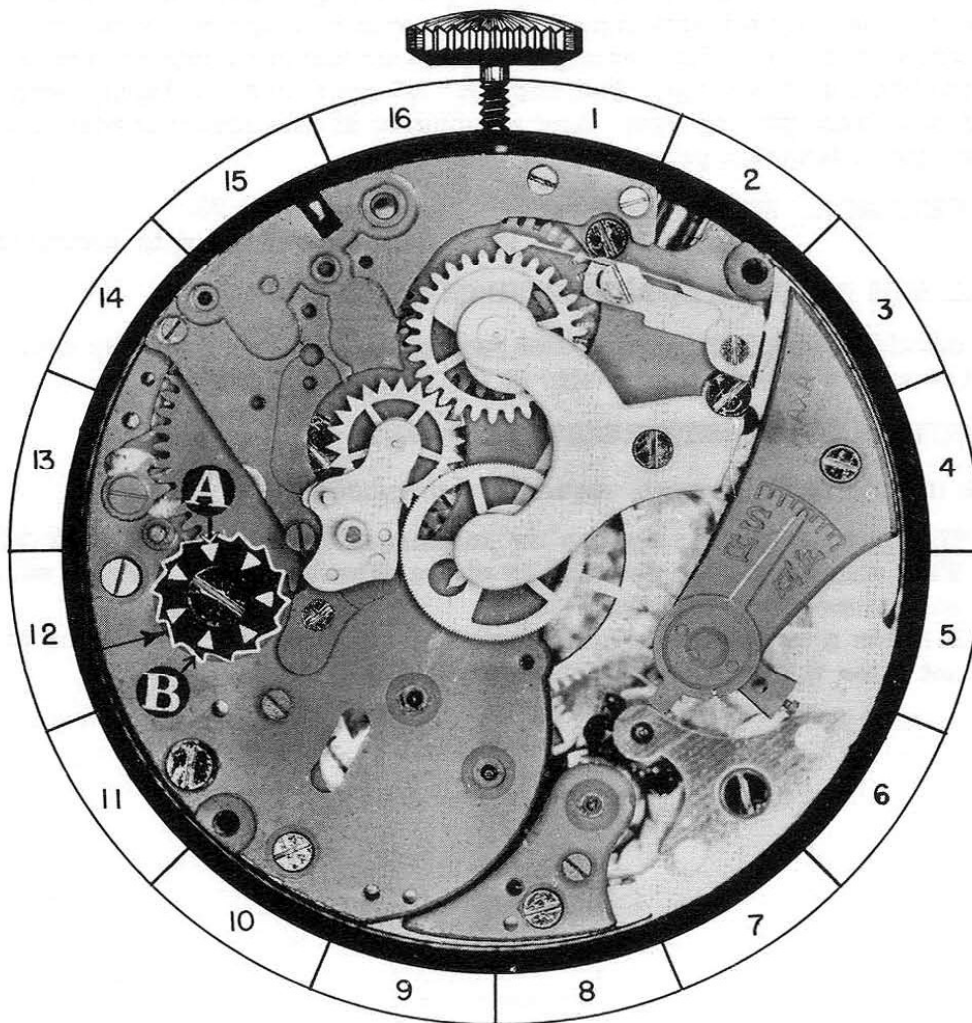

17A

## PART NO. 18

### A. DISASSEMBLY PROCEDURE OF MINUTE REGISTER PAWL:

This pawl is held in place by a fillister head screw FS-3 and a steady pin. Remove this screw, and loosen pawl by sliding a thin blade screwdriver under pawl. When steady pin is free, pawl may be lifted out of place.

(The shape of screw for this part is shown at bottom of page.)

### B. HAZARDS IN DISASSEMBLY OF MINUTE REGISTER PAWL:

The blade on this pawl is extremely delicate and can be easily damaged by a slight slip of the screwdriver. Care must be taken in removing this pawl, so as not to harm it in any way.

### C. ASSEMBLY PROCEDURE OF MINUTE REGISTER PAWL:

Place the pawl on the minute register pawl adjustment plate with steady pin on pawl in proper hole. Now replace fillister head screw FS-3 that holds this pawl in place.

Caution: The amount of tension that end "A" of pawl holds on minute register wheel should be very light, yet strong enough to keep the minute register wheel stationary until the wheel is turned by the chronograph mechanism. Too strong a tension on minute register wheel may cause the watch to stop. The end "A" of pawl must be highly polished and free from pits of rust. Any roughness at this location will cause pawl not to function properly.

REFERENCE: Minute Register Wheel is Assembly 23  
Minute Register Pawl Adjustment Plate is Assembly 19

### D. HAZARDS IN ASSEMBLY OF MINUTE REGISTER PAWL:

Be careful in replacing this pawl as the blade on pawl is very delicate and is easily damaged by a slip of the screwdriver etc.

### E. FUNCTION OF MINUTE REGISTER PAWL:

The minute register pawl serves two purposes:

1. This pawl correctly spaces the turning of the minute register wheel. This eliminates the possibility of the minute register wheel setting at an incorrect position.
2. It holds a tension on minute register wheel so that a bump or jar cannot alter the position of this wheel.

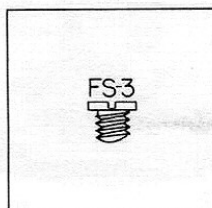



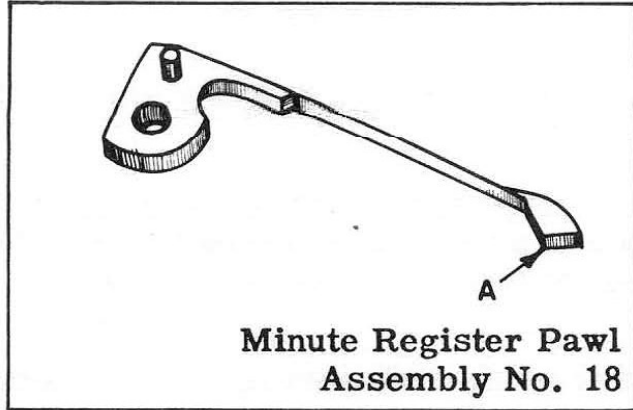

### OILING

The minute register pawl should not be oiled.

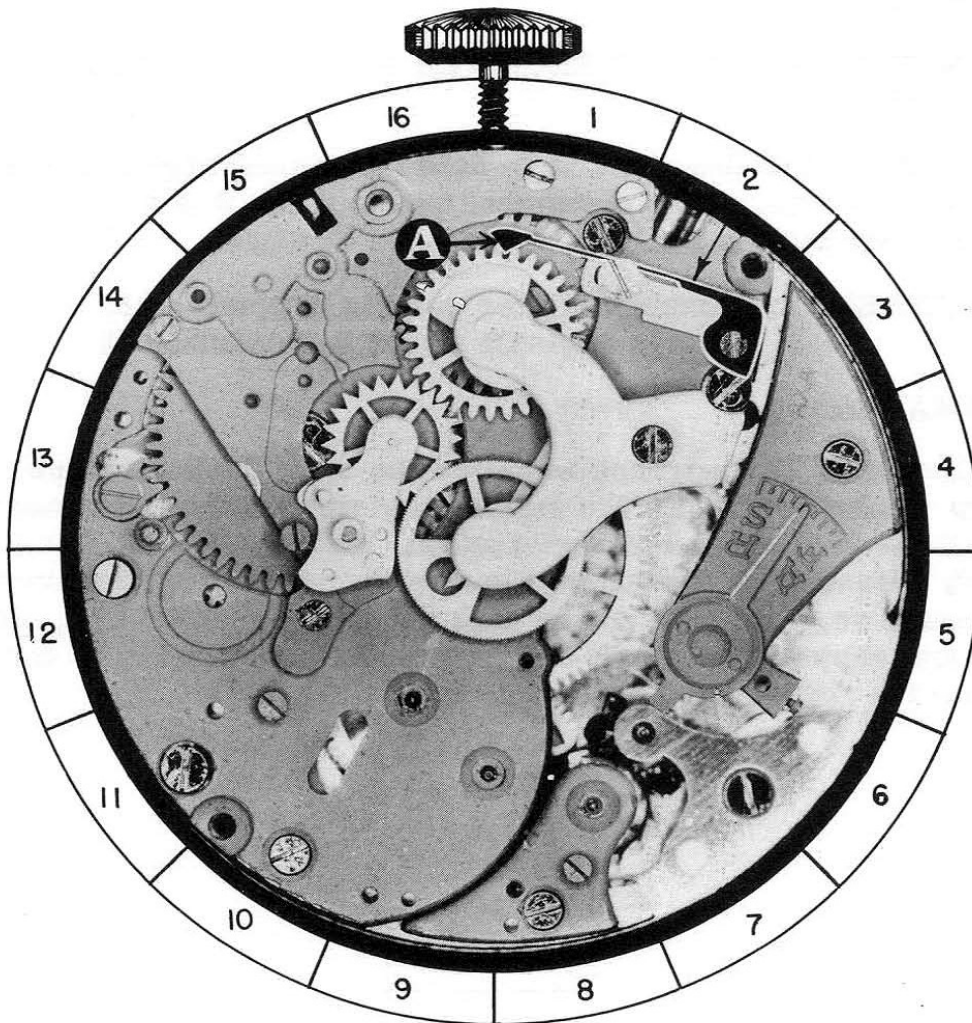

18A

## PART NO. 19

### A. DISASSEMBLY PROCEDURE OF MINUTE REGISTER PAWL ADJUSTMENT PLATE:

To remove this plate, remove shouldered screw SS-8 that holds this plate in place. After screw is removed, the adjustment plate will be free on the movement and can be lifted out of place.

(The shape of screw for this part is shown at bottom of page.)

### B. ASSEMBLY PROCEDURE OF MINUTE REGISTER PAWL ADJUSTMENT PLATE:

Place the minute register pawl adjustment plate in its proper position on the movement, as shown in the photograph. Now replace shouldered screw SS-8 that holds this plate to the movement. The hole "A" in adjustment plate should fit directly over slot in plate.

### C. FUNCTION OF MINUTE REGISTER PAWL ADJUSTMENT PLATE:

The function of this plate is to hold the minute register pawl above the level of the movement and to make it possible to adjust the minute register pawl.

**REFERENCE:** Minute register pawl is Assembly 18.  
Minute register wheel is Assembly 23.

### REMARKS:

This type of chronograph is called the semi-instantaneous type of chronograph. The minute register hand is stationary until the 58th second of registration. Between the 58th and 60th second of registration, the minute register hand moves forward very slowly. At the 60th second of registration, the minute register hand will move forward very quickly to complete the registration of one minute on the dial.

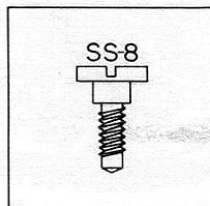

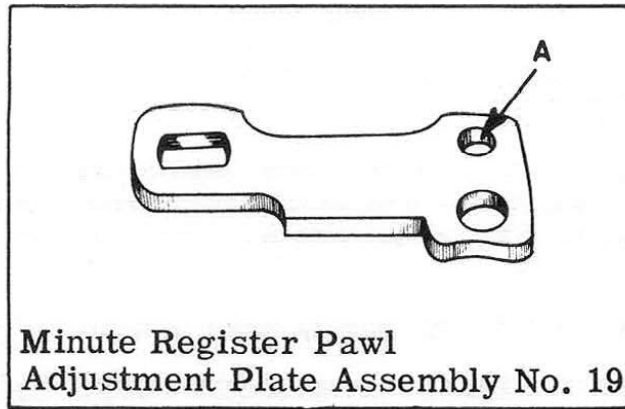

### OILING

The minute register pawl adjustment plate should not be oiled.

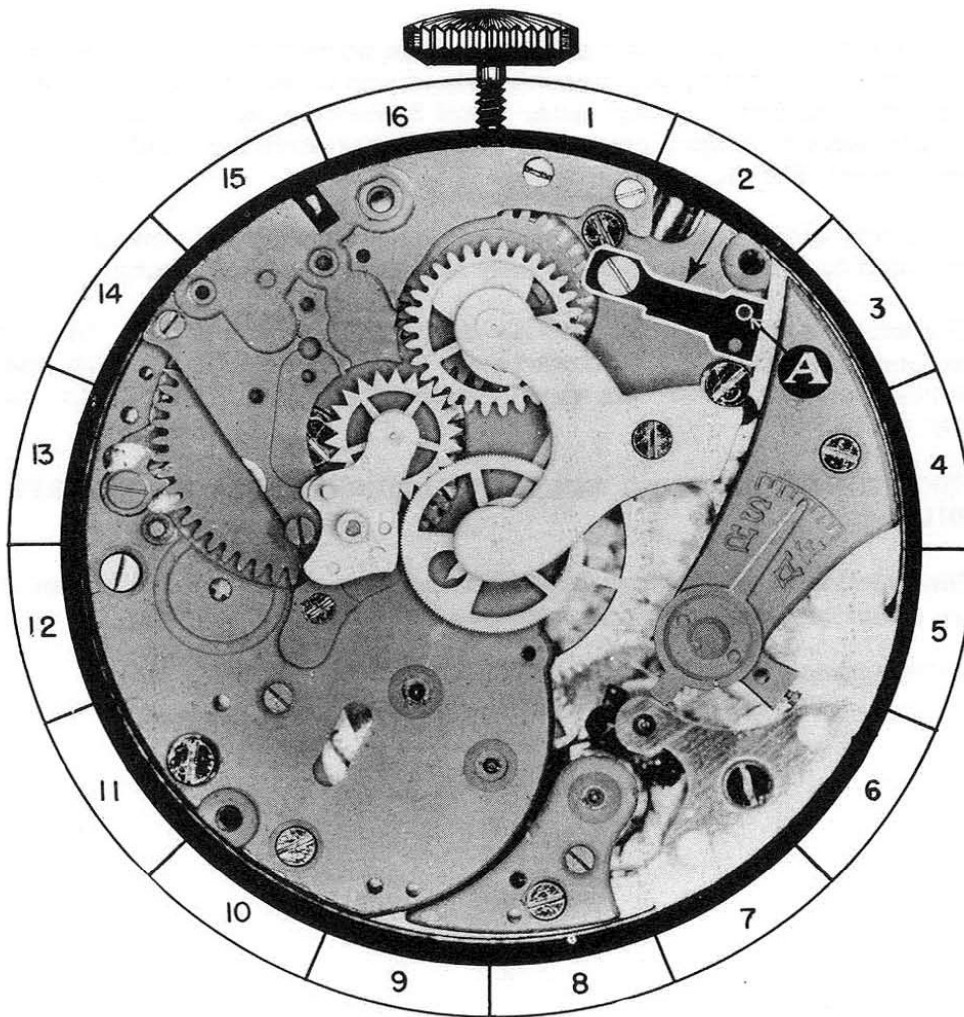

19A

## PART NO. 20

### A. DISASSEMBLY PROCEDURE OF SECONDS WHEEL AND MINUTE REGISTER WHEEL BRIDGE:

This bridge is held in place by fillister head screw F S-4 and steady pins. Remove screw and slide a thin blade screw-driver under bridge to loosen it from the plate. When steady pins are free in the plate, the bridge can be lifted out of place.

(The shape of screw for this part is shown at bottom of page.)

### B. HAZARDS IN DISASSEMBLY OF SECONDS WHEEL AND MINUTE REGISTER WHEEL BRIDGE:

When loosening bridge from plate, be sure to keep bridge level. Any twisting of bridge may burr pivots on seconds wheel or minute register wheel or may chip the jewels in bridge. Also be careful not to mar the plate or bridge with screw-driver when loosening bridge from plate.

### C. ASSEMBLY PROCEDURE OF SECONDS WHEEL AND MINUTE REGISTER WHEEL BRIDGE:

Place bridge in its proper position on the plate, with the steady pins over proper holes. Now place seconds wheel and minute register wheel so the pivots on these wheels enter jewel holes in bridge. Now press bridge down to proper place with back of tweezers and replace fillister head screw F S-4.

After this bridge is replaced, the minute register wheel should be checked to see that it pivots freely and has proper endshake.

The seconds wheel should also be checked for freedom, etc. Of course, the seconds wheel will not spin freely unless the tension on this wheel is released. (The seconds wheel tension spring holds the tension on this wheel.)

### D. FUNCTION OF SECONDS WHEEL AND MINUTE REGISTER WHEEL BRIDGE:

The function of this bridge is to hold the seconds wheel and minute register wheel in position so these wheels can function properly.

REFERENCE: Seconds wheel is Assembly 21.  
Minute register wheel is Assembly 23.

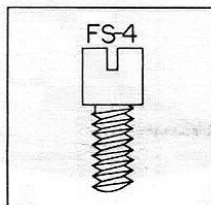



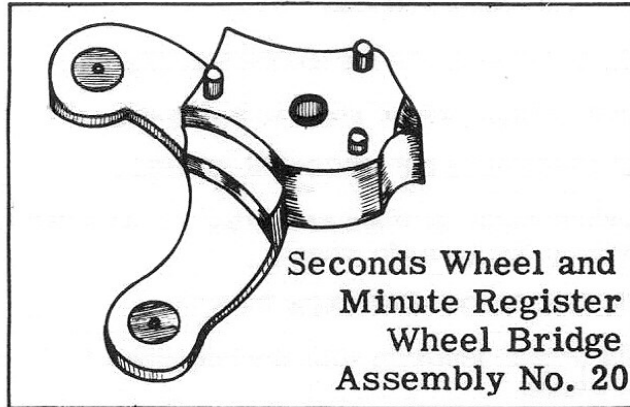

### OILING

The pivots in the jewels in seconds wheel and minute register wheel bridge should be oiled as you usually oil the train pivots in a watch.



20A

## PART NO. 21

### A. DISASSEMBLY PROCEDURE OF SECONDS WHEEL:

The seconds wheel is lifted out of place to remove it.

### B. HAZARDS IN DISASSEMBLY OF SECONDS WHEEL:

Lift seconds wheel straight up when removing it. Any tilting of wheel may bend the pivot on the seconds wheel.

### C. ASSEMBLY PROCEDURE OF SECONDS WHEEL:

Place wheel in its proper position with the long pivot "A" down in hollow center wheel pinion

### D. FUNCTION OF SECONDS WHEEL:

The functions of the seconds wheel are:

1. The seconds wheel registers passage of seconds on the dial. This is done by a hand being attached to the long pivot "A" on seconds wheel.
2. The seconds wheel must move the minute register wheel forward one tooth, each time the seconds wheel makes one revolution. This is done by a dart tooth "C" attached to the seconds wheel. This dart tooth meshes with the teeth on intermittent wheel which, in turn, move the minute register wheel one tooth.
3. The seconds wheel must return to a zero position when the flyback lever is brought in contact with heart on this wheel. Seconds wheel heart is shown as "B" in isometric drawing.

**REFERENCE:** Flyback lever is Assembly 11.

Dart tooth on seconds wheel is shown as "C" on isometric drawing.

Intermittent wheel is shown on Page 24-C.

### REMARKS:

When the flyback lever is forced toward the center of the watch and held at this position, check the seconds wheel and minute register wheel to see if either of these wheels will turn. The minute register wheel should turn slightly at this point, but the seconds wheel should be held very tight by the flyback lever. It is most essential for the seconds wheel to be held stationary by the flyback lever at a zero position. In the case of the minute register wheel, it does not have to be held absolutely stationary by the flyback lever, as the minute register pawl will serve this purpose. The only thing that the minute register wheel should be checked for is to see that the minute register wheel will not turn far enough to one side or to the other to let the minute register pawl drop into another tooth. This will assure that the minute register wheel will always be brought back to a zero position.

The advantage in having the minute register wheel turn slightly when the flyback lever is brought into the center of the watch is that if there is any wear in these parts, the seconds wheel and minute register wheel will still return to a zero position.

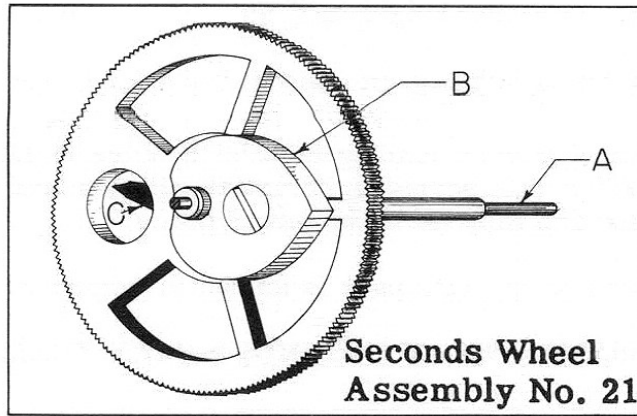

### OILING

The top pivot on seconds wheel should be oiled after bridge, for this wheel is placed in watch. The bottom pivot should not be oiled.

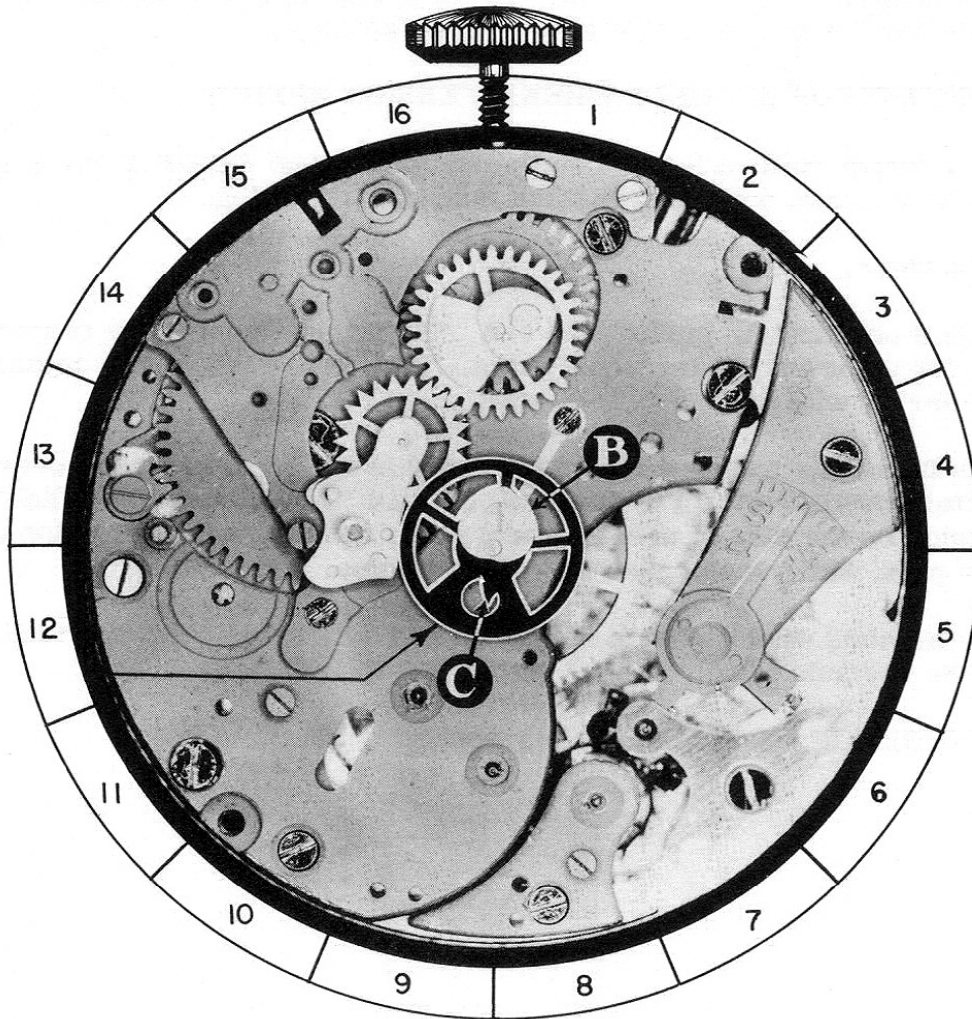

21A

## PART NO. 22

### A. DISASSEMBLY PROCEDURE OF SECONDS WHEEL TENSION SPRING:

The seconds wheel tension spring is held in place by fillister head screw FS-5. After this screw is removed, the tension spring will be free on the plate and may be lifted out of place.

(The shape of screw for this part is shown at bottom of page.)

### B. ASSEMBLY PROCEDURE OF SECONDS WHEEL TENSION SPRING:

Place seconds wheel tension spring in its proper place with hole in spring over proper hole in plate. Replace fillister screw FS-5, but before tightening screw, center end "A" of spring over bushing for center wheel pivot. Screw may now be tightened to hold spring in proper position. After spring is replaced and screw is tight, check end "A" of spring again and make sure it is still centered over bushing hole for center wheel. This spring should also be checked to make sure that it is right side up. The way to determine the side that should be up is to see that end "A" of spring is above the level of the plate and the polished side of spring is facing up.

### C. FUNCTION OF SECONDS WHEEL TENSION SPRING:

This spring holds a tension on the seconds wheel so that it turns with an even action, with no irregular jumping or jerking.

#### REMARKS:

When replacing the spring, the end "A" of spring must be centered over bushing for center wheel pivot. This is to prevent any contact of the spring with seconds wheel staff.

It is important to see that end "A" of this spring is centered over the center wheel pivot, for if it is not, the end "A" of spring will hold a tension on the side of second wheel staff, causing excess friction on this part, which may cause the watch to stop.

The seconds wheel tension spring should only hold an upward tension on the seconds wheel.

REFERENCE: Seconds wheel is Assembly 21.

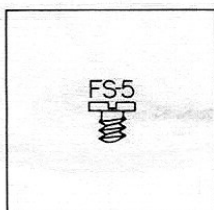



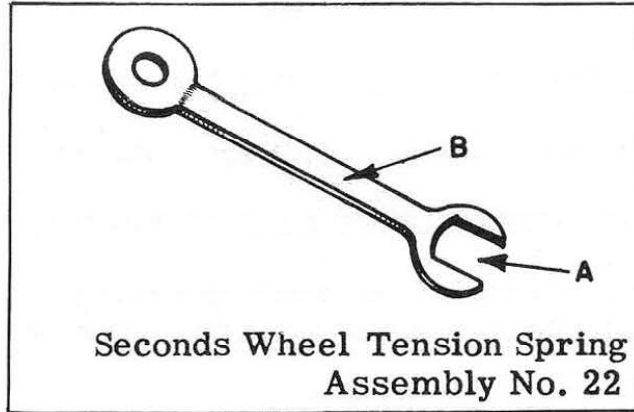

### OILING

The seconds wheel tension spring should not be oiled.

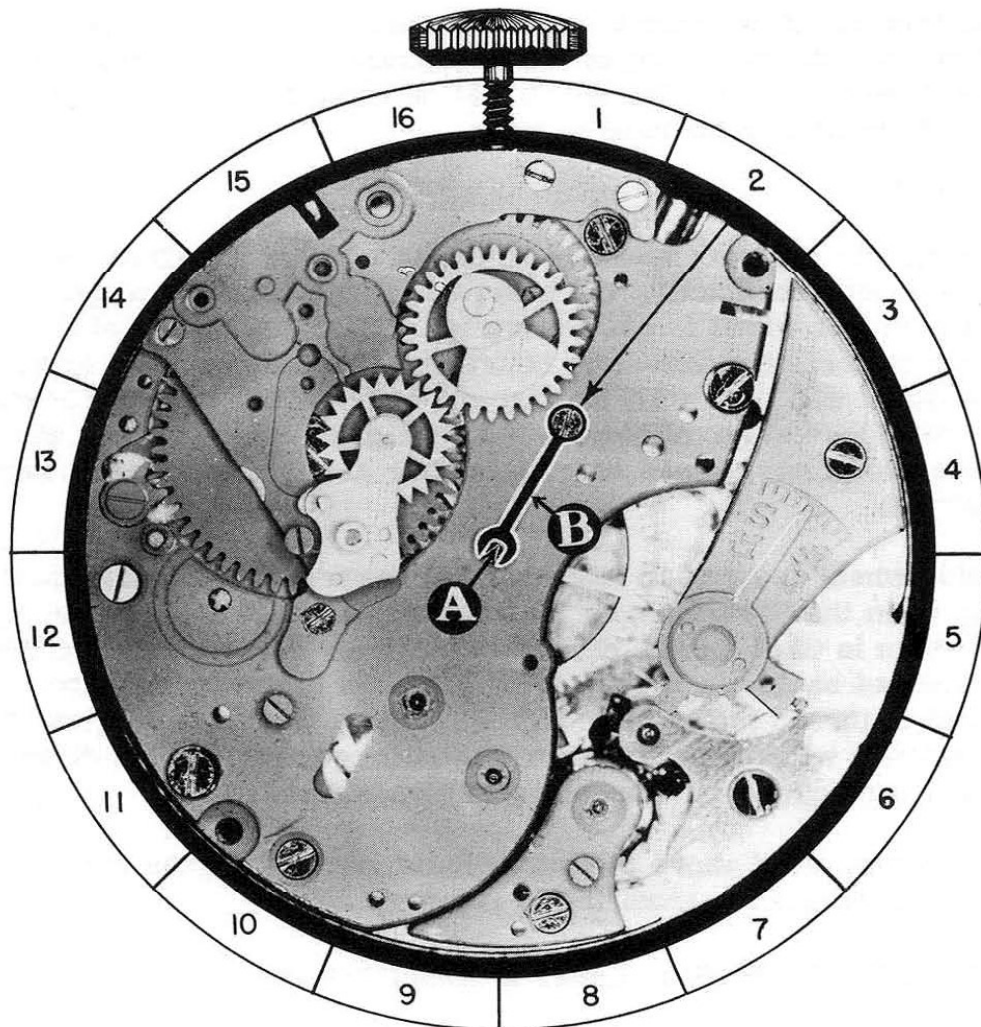

22 A

## PART NO. 23

### A. DISASSEMBLY PROCEDURE OF MINUTE REGISTER WHEEL:

To remove this wheel, simply lift it out of place.

### B. HAZARDS IN DISASSEMBLY OF MINUTE REGISTER WHEEL:

When removing this wheel, lift wheel straight up out of watch, as any twisting may bend or break the pivot on the minute register wheel.

### C. ASSEMBLY PROCEDURE OF MINUTE REGISTER WHEEL:

Place the minute register wheel in its proper position in the watch, as shown in the photograph, with the long post "A" of this wheel down in plate.

### D. FUNCTION OF MINUTE REGISTER WHEEL:

The function of the minute register wheel is to record the minutes since the beginning of the registration of the chronograph sweep second hand. The heart "B" of minute register wheel is used in returning the hand to zero.

#### REMARKS:

The minute register wheel is returned to a zero position by the flyback lever contacting the heart on minute register wheel. The heart on this wheel is set eccentric. When the flat end of flyback lever contacts the eccentric heart, it forces the heart to turn. The heart will turn until the flat end of flyback lever sets across the two lobes at top of heart. With the pressure equalized at these two points, it will turn no further and this would be a zero position.

If this wheel has turned less than 160 degrees from a zero position when the flyback lever is brought in contact with the heart, it will turn in the opposite direction to which it was turning to bring this wheel back to a zero position. On the other hand, if the wheel is turned passed 160 degrees from a zero position, the flyback lever will force the heart to continue to turn in the direction it was turning until it reaches a zero position.

The degree used above is approximate, as this degree varies in most chronographs from 150 to 170 degrees.

**REFERENCE:** Flyback Lever is Assembly 11.

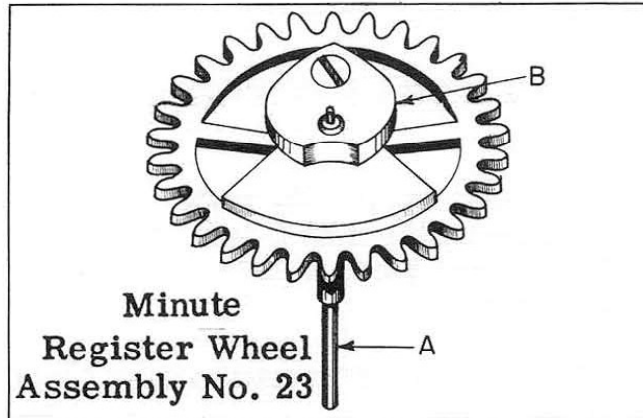

### OILING

The top and bottom pivots on minute register wheel should be oiled after bridge, for this wheel is placed in watch. Oil these pivots as you usually oil the train pivots in a watch.

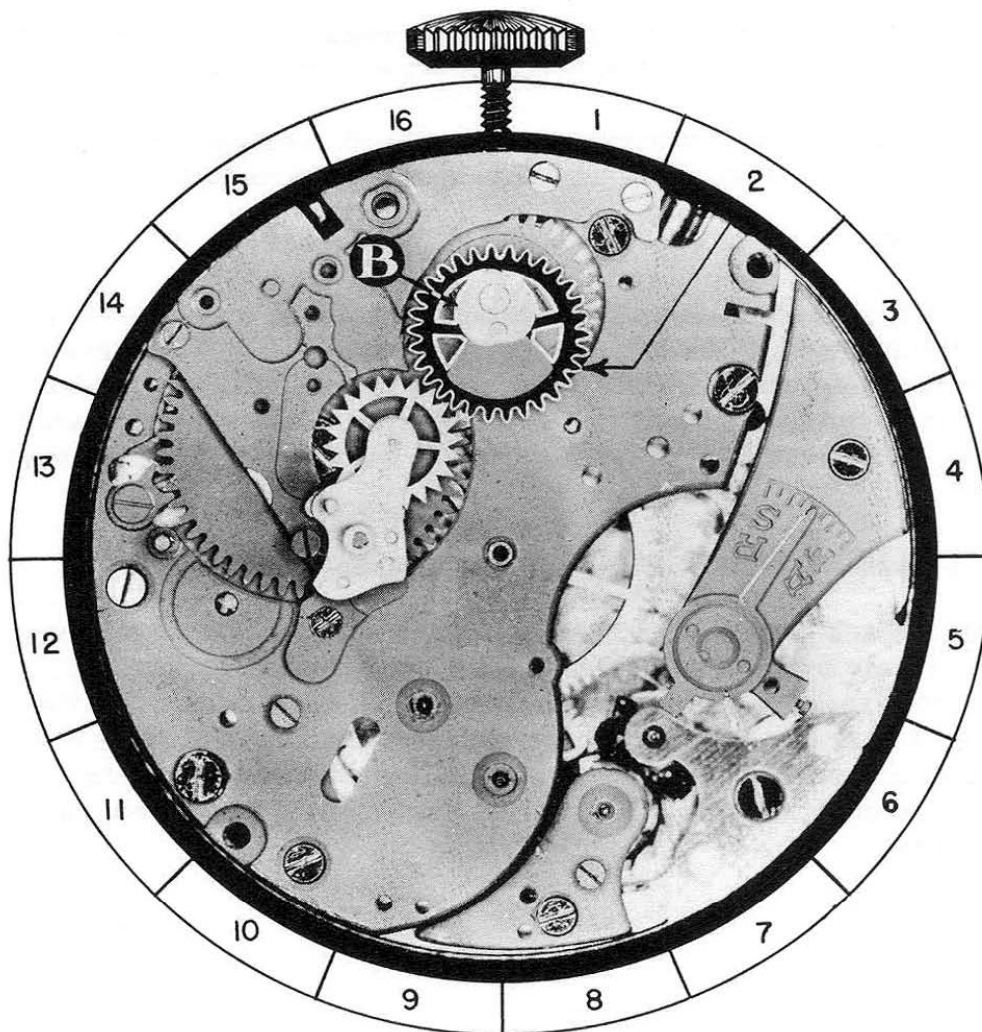

23A

PART NO. 24

**A. DISASSEMBLY PROCEDURE OF INTERMITTENT LEVER AND WHEEL ASSEMBLY:**

This assembly pivots on a post in the plate. To remove it, grip bushing "B" on this assembly with a pair of tweezers and lift straight up. This will free the intermittent lever and wheel assembly from the post on plate.

**B. ASSEMBLY PROCEDURE OF INTERMITTENT LEVER AND WHEEL ASSEMBLY:**

Place hole in bushing in intermittent lever over proper post on plate as shown in photograph. Now press assembly down on post to its proper place. Check this assembly to see that it pivots freely on this post.

**C. FUNCTION OF INTERMITTENT LEVER AND WHEEL ASSEMBLY:**

The function of intermittent lever is to engage and disengage the intermittent wheel with the seconds wheel dart tooth.

**REFERENCE:** Intermittent wheel is shown on Page 24-C.  
Seconds wheel dart tooth is Assembly 21-C.

**REMARKS:**

The VEE shaped teeth on the intermittent wheel mesh into the epicycloid teeth of the minute register wheel. The VEE shaped teeth meshing with the epicycloid teeth has an advantage, as the back lash can be reduced to a minimum, also the straight faces of the VEE shaped teeth work better in conjunction with the dart tooth.

**REFERENCE:** Minute register wheel is Assembly 23.

**NOTE:** Each part that is held in place by a shouldered screw should move freely under the head of screw, and should be checked for the required freedom. Any excess freedom is not desired. In the case where a part has too much vertical movement or endshake under the head of a shouldered screw, the shoulder on the screw may be too long. To correct this, cut back the shoulder on the screw reducing the length of it.



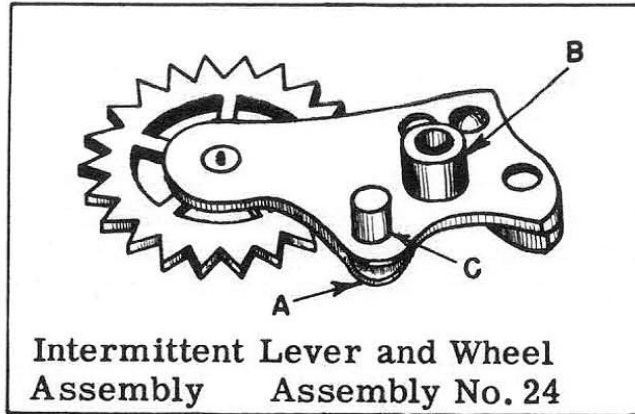

### OILING

The post that intermittent lever and wheel assembly pivots on should be slightly moistened with oil.

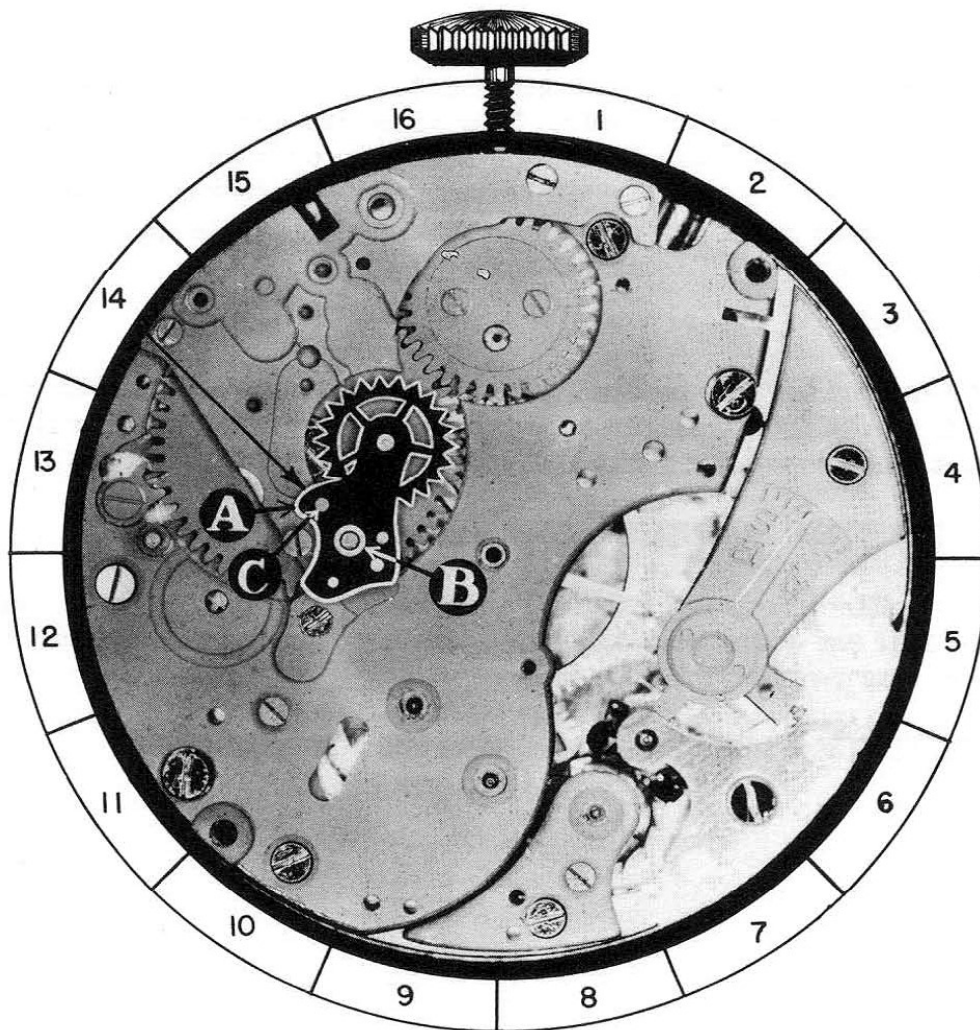

24A

PART NO. 24-B

**A. DISASSEMBLY PROCEDURE OF INTERMITTENT WHEEL AND BRIDGE:**

This bridge is held in place by fillister head screw FS-6 and steady pins. When this screw is removed, the bridge can be lifted out of place and free from intermittent lever. After bridge is removed, the intermittent wheel can be lifted out of place with a pair of tweezers.

(The shape of screw for this part is shown at bottom of page.)

**B. HAZARDS IN DISASSEMBLY OF INTERMITTENT WHEEL AND BRIDGE:**

When removing this wheel, lift wheel straight out of place without tilting it, as any tilting of this wheel may bend or break the pivot of this wheel.

**C. ASSEMBLY PROCEDURE OF INTERMITTENT WHEEL AND BRIDGE:**

Place the intermittent wheel with the pivot "A" on wheel in pivot hole in the intermittent lever. Now place the bridge on the intermittent lever, with steady pins on bridge entering proper holes in lever. Make sure that the intermittent wheel pivot is entering pivot hole in intermittent lever bridge. Now press bridge down to proper place and replace fillister head screw FS-6.

**REMARKS:**

After the bridge is replaced, check the intermittent wheel to see that it pivots freely and is not binding. Also check this wheel to see that it has proper endshake.

**D. FUNCTION OF INTERMITTENT WHEEL AND BRIDGE:**

The function of the intermittent wheel is to move the minute register wheel one tooth each time the dart tooth, on seconds wheel, makes one revolution.

**REFERENCE:** Minute register wheel is Assembly 23.  
Seconds wheel is Assembly 21.

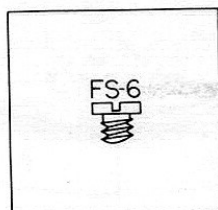

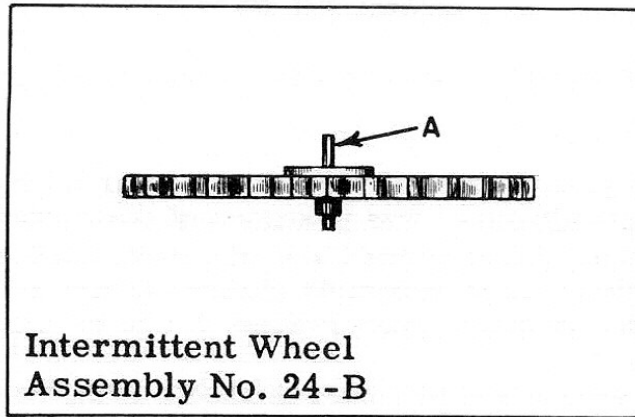

### OILING

The intermittent wheel should not be oiled.

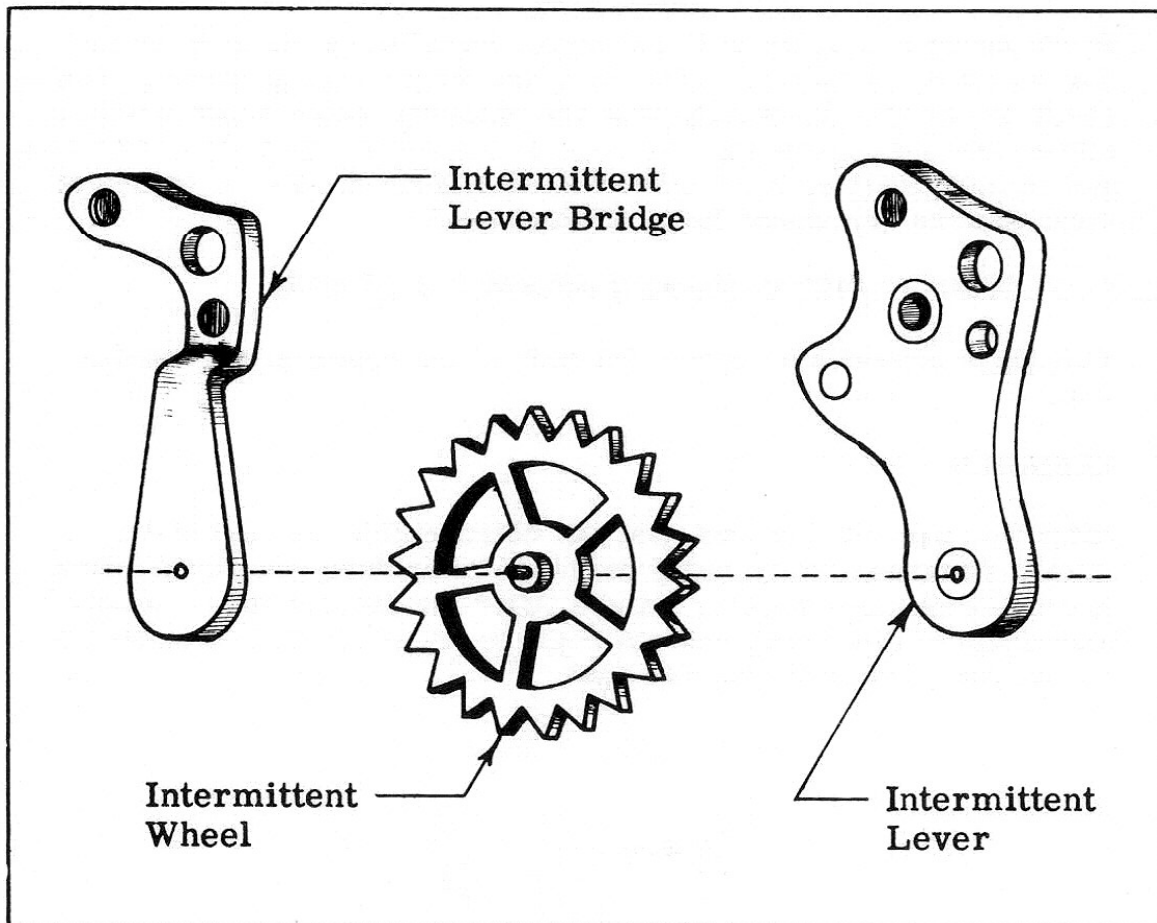

## PART NO. 25

### A. DISASSEMBLY PROCEDURE OF CHRONOGRAPH ASSEMBLY PLATE:

This assembly plate is held in place by fillister head screws FS-7 and FS-8 and steady pins. The positions of these screws are shown in the photograph. After screws are removed, slide a finely-sharpened screw-driver under assembly plate to loosen it from the movement. After the assembly plate is free, it can be lifted out of place.

(The shape of screws for this part is shown at the bottom of page.)

### B. HAZARDS IN DISASSEMBLY OF CHRONOGRAPH ASSEMBLY PLATE:

When loosening this plate from movement by sliding a finely-sharpened screw-driver under this plate, care should be taken so as not to mar the assembly plate or the movement plate.

### C. ASSEMBLY PROCEDURE OF CHRONOGRAPH ASSEMBLY PLATE:

Place the assembly plate in its proper position on the movement. The hole "A" in this plate fits over the detent setting screw. Now check to see that the steady pins are entering their proper holes in movement; then press the chronograph assembly plate down in place, and replace fillister head screws FS-7 and FS-8. The positions of these screws are shown in the photograph.

### D. FUNCTION OF CHRONOGRAPH ASSEMBLY PLATE:

This plate provides a support for part of the chronograph mechanism.

#### REMARKS:

After this part is removed, you can disassemble the rest of the watch. Disassemble it, using the same procedure you would follow in disassembling a regular watch. After the movement is assembled again to this point, you can begin to assemble the chronograph mechanism, starting with this part.

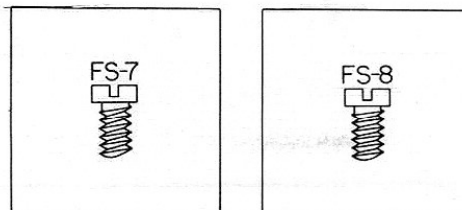



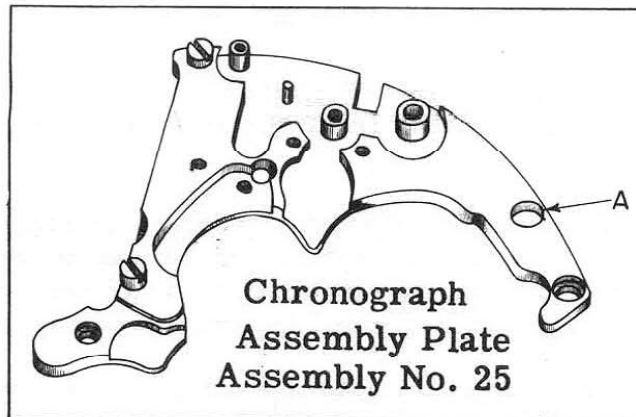

### OILING

The chronograph assembly plate should not be oiled.

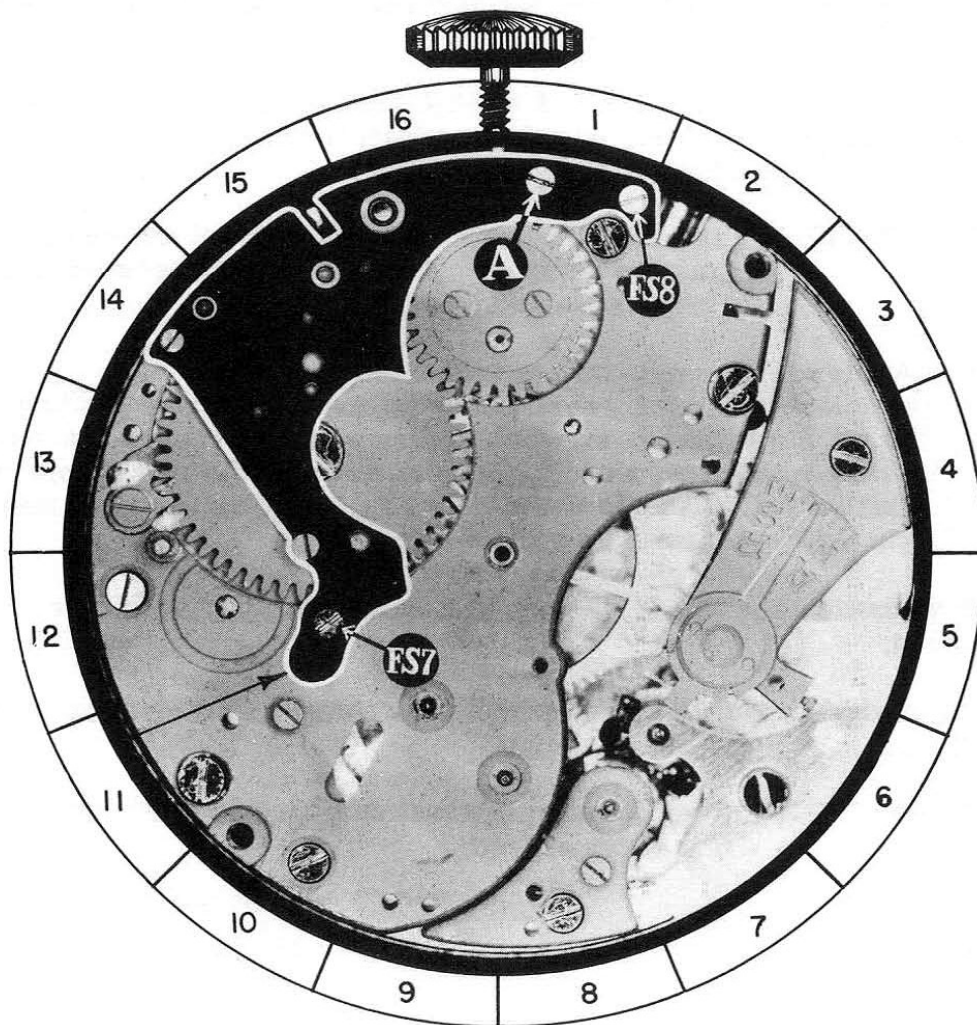

25A

## FUNCTIONAL RESULTS

After completely assembling the chronograph with exception of the back of the case, place chronograph in front of you, pendant up, with back of chronograph facing you.

1. Push the button at left of the pendant. This should release the flyback lever, so that the flyback lever can be forced toward the center of the watch. (Make sure that the castle wheel is in its proper position, so that the flyback lever can be forced toward the center of the watch.)
  - A. Check to see that seconds wheel and minute register wheel return the hands connected to these wheels to a zero position.

**CORRECTION:** The following errors could prevent these hands from returning to a zero position:

1. Loose hands, or hands not being set correctly.
  2. The minute register wheel or the seconds wheel binding and not turning freely.
  3. The flyback lever spring not holding a strong enough tension on flyback lever.
- B. Check to see that end "A" of minute register pawl is directly centered between two teeth on minute register wheel, when this wheel is at a zero position.

**CORRECTION:** The following errors could prevent the end of minute register pawl from setting between two teeth on minute register wheel:

1. The minute register pawl not adjusted properly.
  2. The minute register wheel or the intermittent wheel binding.
  3. The minute register pawl not holding a strong enough tension on minute register wheel. (Failure to have this pawl properly adjusted will result in the minute register wheel moving after flyback lever moves away from the heart.)
2. Push the button at right of the pendant, release it, and check the following:

- A. Check depthing of teeth on intermediary wheel with teeth on seconds wheel.

**CORRECTION:** The following errors could prevent correct depthing of these teeth:

(Continued on next page.)

**FUNCTIONAL RESULTS**  
(Continued)

1. Chronograph pivoted detent spring not holding enough tension on chronograph pivoted detent.
2. Chronograph pivoted detent not turning freely.
3. Improperly adjusted eccentric stud ES-2. (See adjustment of eccentric studs in front of book.)

B. Check depthing of seconds wheel dart tooth with intermittent wheel teeth.

**CORRECTION:** The following errors could prevent proper depthing of dart tooth with intermittent wheel teeth:

1. Intermittent lever not turning freely on post in plate.
2. Intermittent lever spring not holding enough tension of intermittent lever.
3. Improperly adjusted eccentric stud could prevent proper depthing of these parts. (See adjustment of eccentric studs in front of book.)

**REMARKS:**

If the depthing of the intermittent wheel teeth with the seconds wheel dart tooth is too deep, the minute register wheel may move two teeth each time the seconds wheel dart tooth makes one revolution. If the depthing is shallow, it may cause the minute register wheel not to move a full tooth and thus will not register the minutes on the dial.

C. Check to see that seconds hand moves forward in a steady manner, with no irregular jumping or jerking.

**CORRECTION:** This irregular movement of second hand is usually caused by the seconds wheel tension spring not holding enough tension on the seconds wheel.

3. Push the button at right of the pendant a second time. Release it, and check the following: Check to see that brake lever is in contact with the seconds wheel.

**CORRECTION:** The following errors could prevent brake lever from contacting seconds wheel:

1. Brake lever not turning freely under head of screw.
2. Brake lever spring not holding enough tension on brake lever.

**DIRECTIONS FOR READING CHRONOGRAPH DIAL  
THE TACHOMETER**

- A. The tachometer is used to indicate the speed of an object in miles per hour. A tachometer can only indicate the average speed of an object traveling over a course of a measured mile.

**METHOD OF USING TACHOMETER**

1. Start chronograph sweep second hand at the exact moment the object starts to travel the measured distance of one mile.
2. When the object has traveled the course of one mile, stop the chronograph sweep second hand. The point on the tachometer scale where the sweep second hand stopped will indicate the average speed in miles per hour.

**SPLIT SECOND SCALE**

- B. This scale is divided into 300 divisions, each indicating  $\frac{1}{5}$  of a second. Every fifth division is marked with extra long lines denoting one second.

The main purpose of this scale is to measure a fraction of a second accurately.

**SECOND HAND**

- C. The second hand indicates the passing of seconds and should move one space each second. One complete revolution of hand denotes passage of one minute. This hand is independent of chronograph mechanism and continues to register the seconds as long as watch is running.

**TELEMETER**

- D. The telemeter is used to denote the number of miles between two points. This is done by comparing the speed of light to the speed of sound.

**METHOD OF USING TELEMETER**

1. Start chronograph sweep second hand when you see lightning.
2. Stop the chronograph sweep second hand when you hear the thunder. The point on the telemeter scale, where the sweep second hand stopped, will indicate the distance in miles the lightning is away from you.

**MINUTE REGISTER**

- E. The minute register hand registers the number of minutes the chronograph has been in operation. This hand should move forward one space each minute that the chronograph is in operation.



## THE CHRONOGRAPH DIAL

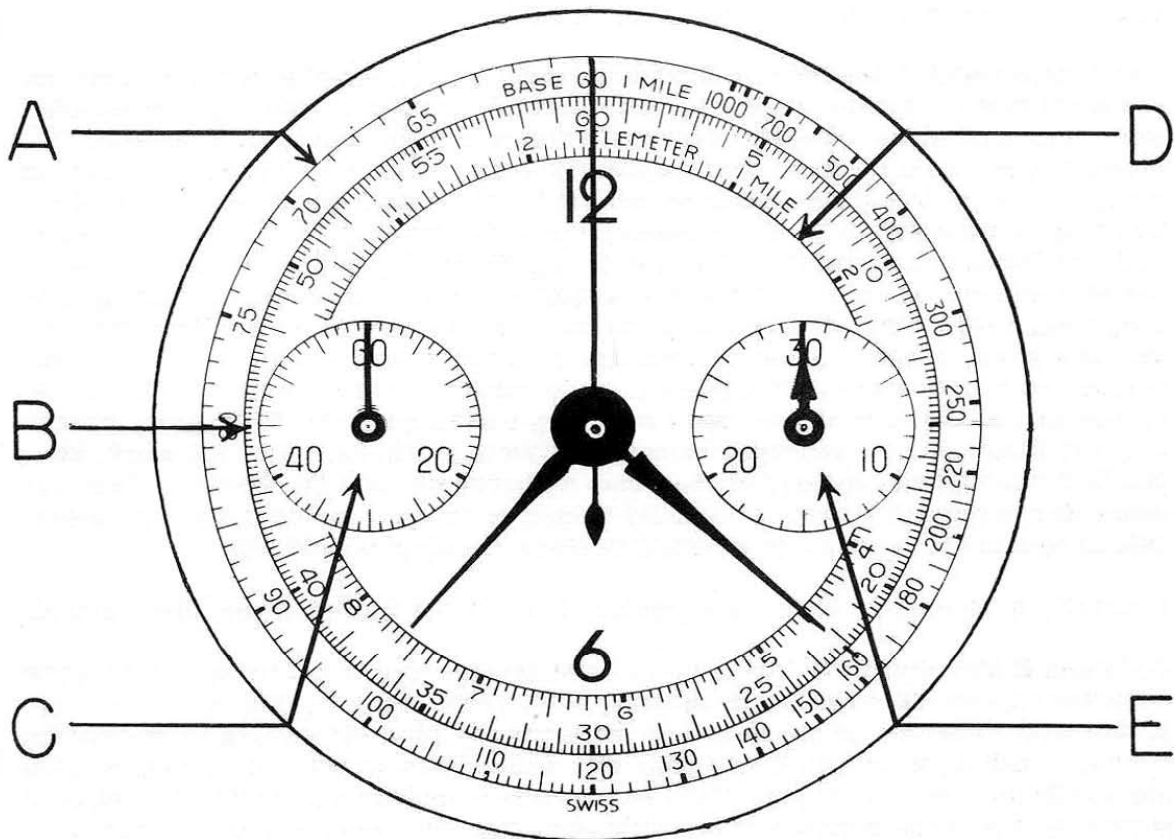

### SETTING THE HANDS CORRECTLY ON A CHRONOGRAPH:

After the chronograph is completely assembled and in working condition, place chronograph in its case. Now replace the hands, replace the hour hand, minute hand and second hand as you would on a regular watch. At this point, do not replace the sweep second or the minute register hand. Now push the button and bring the flyback lever in toward the center of the watch. When the flyback lever is held in toward the center of the watch, place the sweep second hand at 60 on split second scale 'B'. Place the minute register hand at 30 on minute register scale 'E'. After these hands are replaced, start chronograph mechanism with sweep second hand turning. Leave chronograph mechanism run for at least one minute, now push the button to bring the flyback lever in toward the center of the watch again, and check to see that the minute register hand and the sweep second hand goes back to their original position.